

montage handleiding

Begra R4053 rolplateau

Deze handleiding is van toepassing op de volgende modellen

BM254-001-A / Rolplateau licht 1 niveaus / 120kg 544X409X193mm (LxBxH) - 530X400mm (LxB)

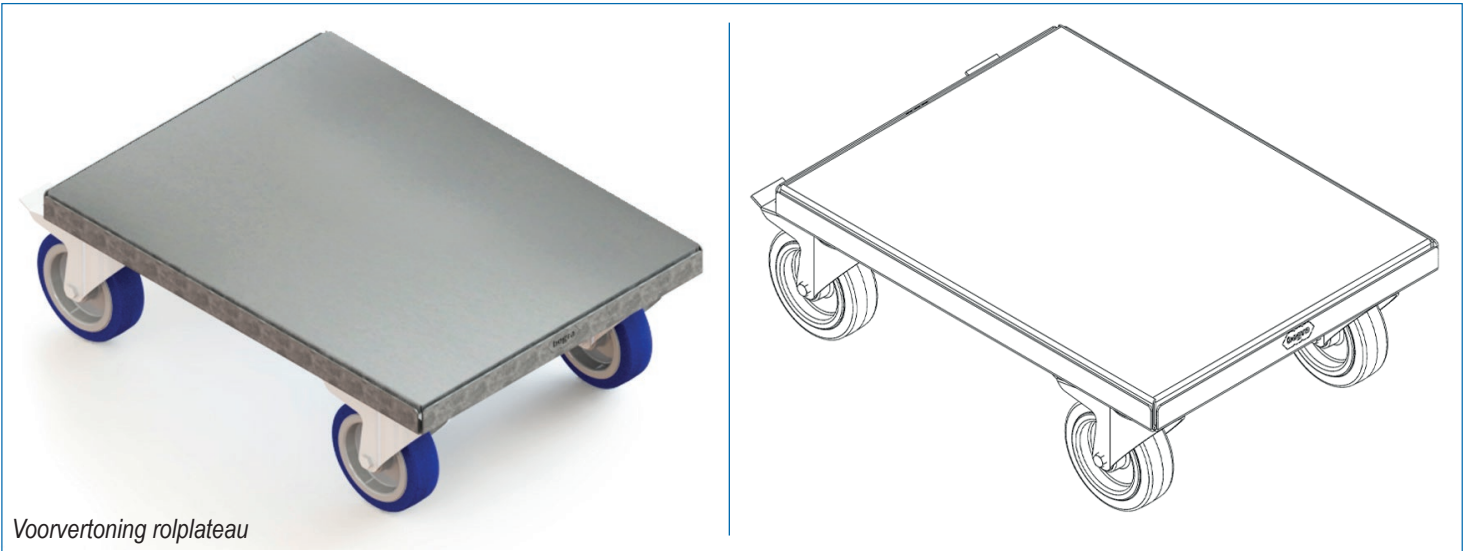

Explosietekening plateauwagen

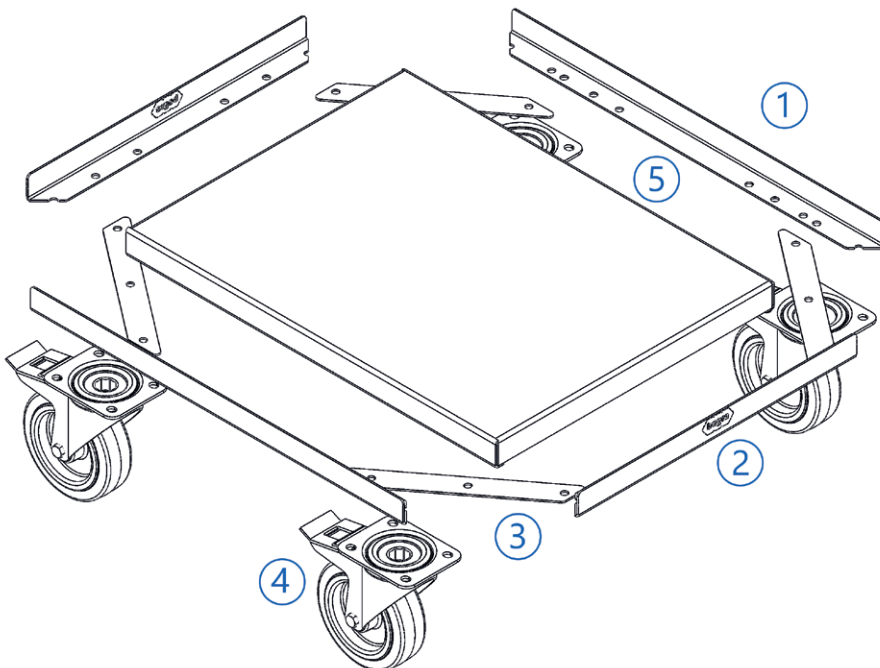

Onderdelen lijst

- ① Hoekprofiel plateauligger lang
 - ② Hoekprofiel plateauligger kort
 - ③ Diagonale verstevigungsstrip
 - ④ Zwenkwiel
 - ⑤ Legbord MD
- Bevestigingsmateriaal

Montagetijd:

 **10 minuten**

Moelijkheidsgraad:



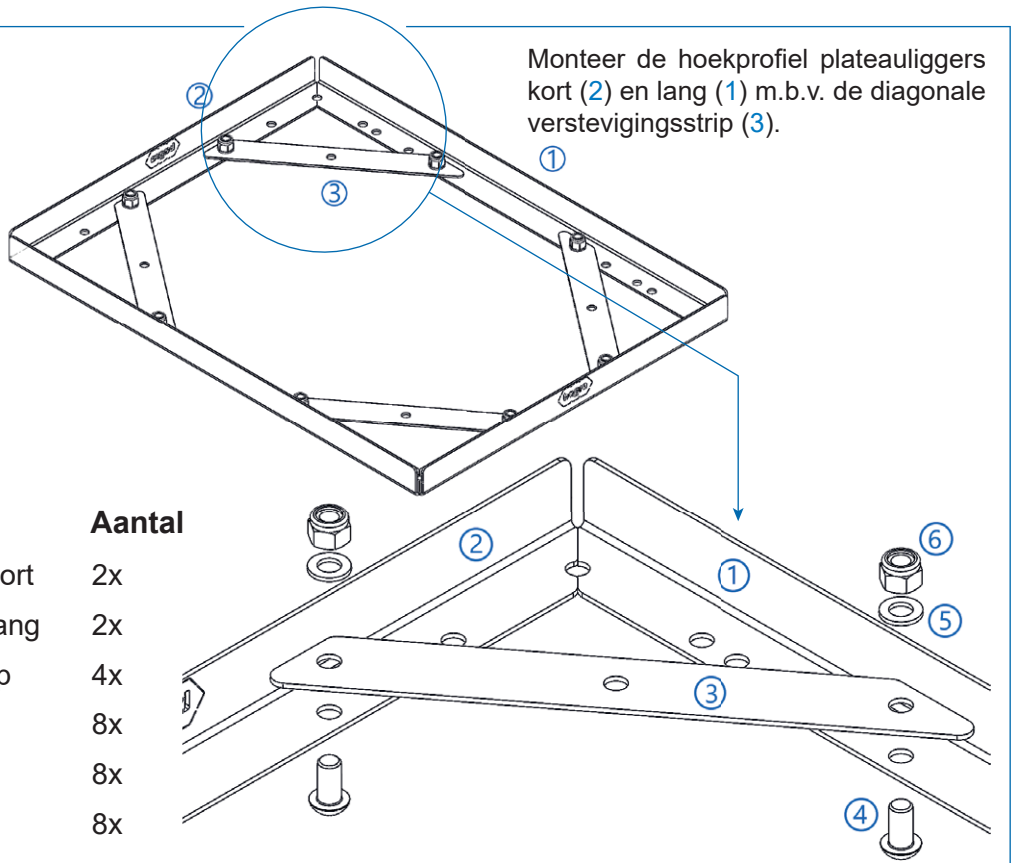
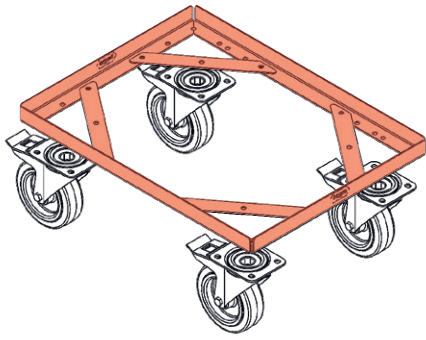

Nr.	Onderdeel	Aantal
①	Hoekprofiel plateau ligger kort	2x
②	Hoekprofiel plateau ligger lang	2x
③	Diagonale versterkingsstrip	4x
④	Bolkopschroef M8x16	8x
⑤	Sluitring M8	8x
⑥	Borgmoer M8	8x

Montage van de wielen

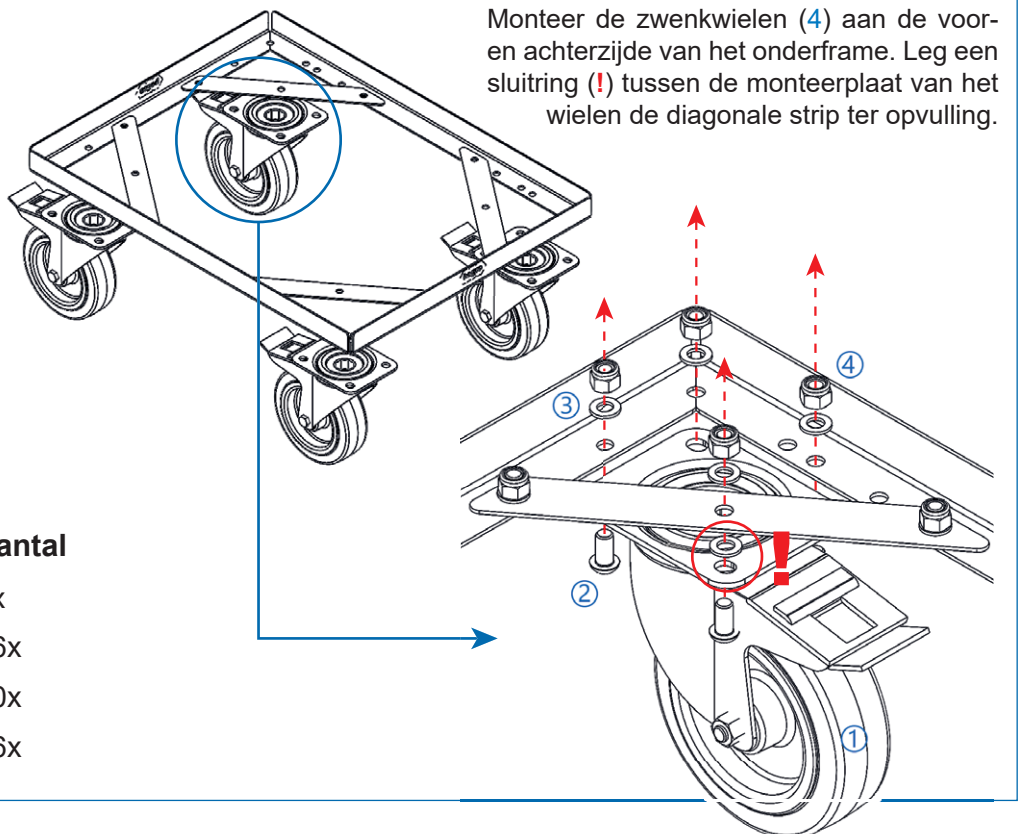
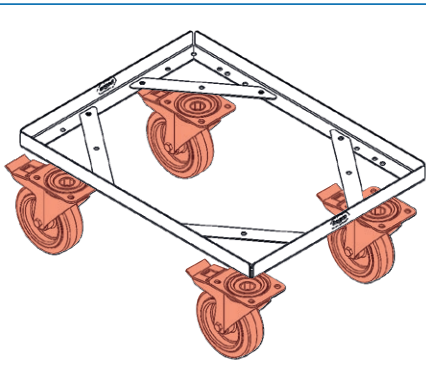

Nr.	Onderdeel	Aantal
①	Zwenkwiel	4x
②	Bolkopschroef M8x16	16x
③	Sluitring M8	20x
④	Borgmoer M8	16x

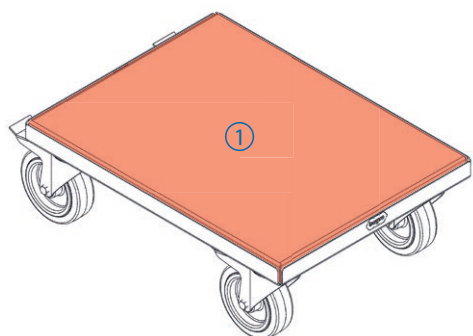

Plaats het legbord MD (1)
op het onderstel

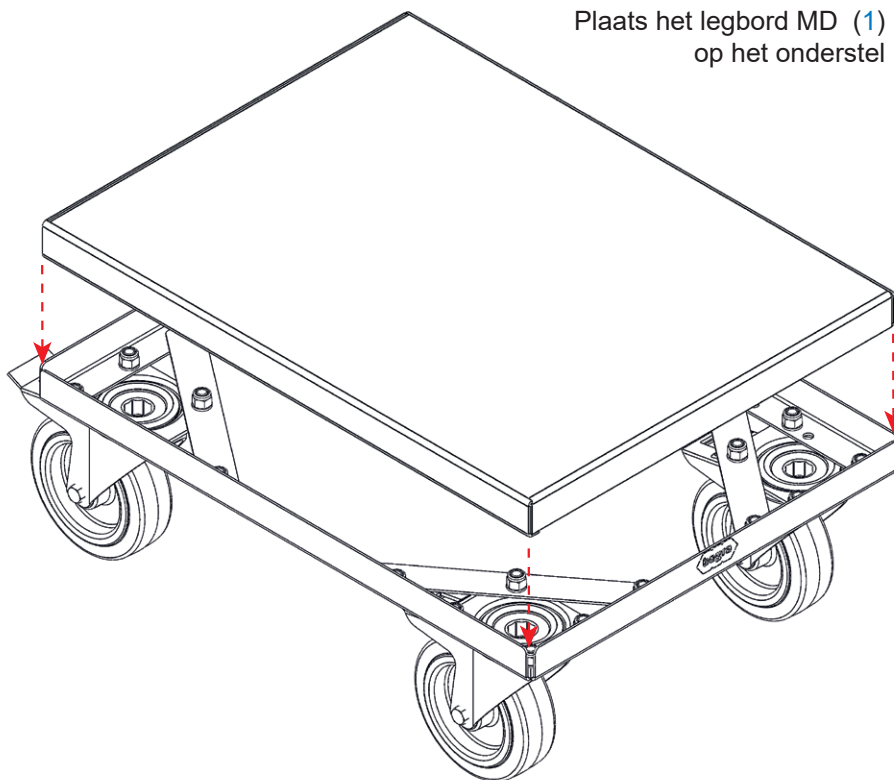

Nr.	Onderdeel	Aantal
1	Legbord MD	1x