

INSTALLATION INSTRUCTIONS

31

Live storage system KDR

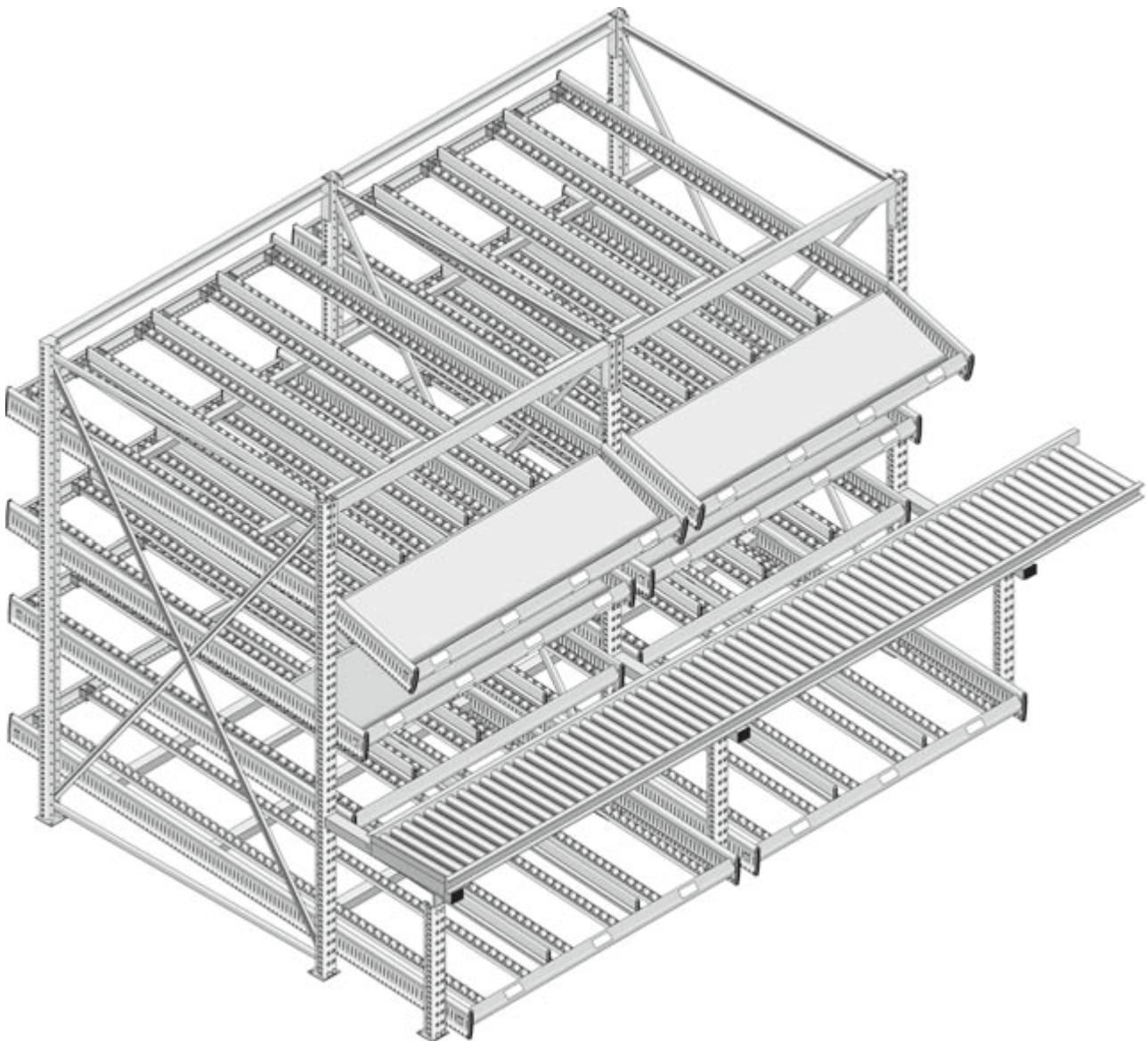

SSI SCHÄFER
FRITZ SCHÄFER GMBH
Manufacturers of warehouse,
production and office equipment,
waste management and recycling

Fritz-Schäfer-Straße 20
D-57290 Neunkirchen / Siegerland
Tel. +49 / (0) 27 35 / 70-1
Fax +49 / (0) 27 35 / 70-3 96
eMail info@ssi-schaefer.de
www.ssi-schaefer.de

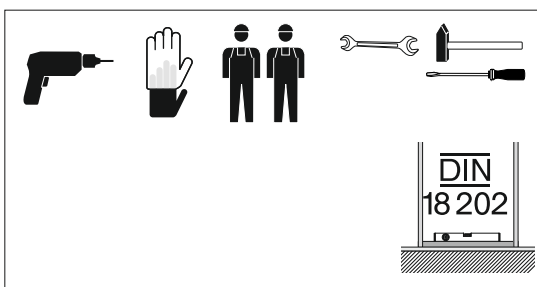

1.0 Contents

1.0	Contents	2	7.0	Assembly of flow bed frame	27
2.0	Warnings	3	7.1	System components for live storage racking KDR – Flow bed frame modules	28
3.0	Safety instructions / important information	3	7.2	Pre-assembly of the side profiles	29
3.1	Shelving setup	3	7.2.1	Bending of the side walls	29
3.2	Checking the floor conditions for the shelving setup	4	7.2.2	Pre-assembly of the front side profiles	30
3.3	Deviation from the vertical	4	7.2.3	Pre-assembly of the rear side profiles	30
3.4	Operating and usage instructions	4	7.3	Ergonomics and adjustment options for the flow bed frame	31
4.0	Frame types	6	7.3.1	Height adjustment options for upright profiles P 63 and P 65	31
5.0	Assembly of KDR starter and extension bays, socketed stanchion, two frames one behind the other for large depths and starter bay with undercarriage	7	7.3.2	Height adjustment options for upright profiles P 73, P 93, P 95, P 13 and P 15	32
5.1	Upright profiles	7	7.4	Attaching the side profiles	32
5.2	Assembly of KDR starter and extension bays for frames P 63 or P 65 with Z framework	7	7.4.1	Attaching the front side profiles for upright profiles P 63 and P 65	33
5.2.1	Dimensions and parts list	7	7.4.2	Attaching the internal side profiles for upright profiles P 63 and P 65	33
5.2.2	Assembly of frames P 63 or P 65 with Z framework	8	7.4.3	Attaching the rear side profiles for upright profiles P 63 and P 65	34
5.3	Assembly of KDR starter and extension bays for frames P 63 or P 65 with X framework	10	7.4.4	Safety clips for upright profiles P 63 and P 65	34
5.3.1	Dimensions and parts list	10	7.4.5	Attaching the front side profiles for upright profiles P 73, P 93, P 95, P 13 and P 15	35
5.3.2	Assembly of frames P 63 or P 65 with X framework	11	7.4.6	Attaching the internal side profiles for upright profiles P 73, P 93, P 95, P 13 and P 15	35
5.4	Assembly of socketed stanchion for frames P 63 or P 65 with X or Z framework	12	7.4.7	Attaching the rear side profiles for upright profiles P 73, P 93, P 95, P 13 and P 15	36
5.4.1	Dimensions and parts list	13	7.4.8	Safety clip	37
5.4.2	Assembly of the socketed stanchion with frames P 63 and P 65	13	7.5	Overview of flow bed frame	37
5.5	Floor anchoring	14	7.5.1	Overview of flat flow bed frame	37
5.6	Undercarriage assembly	14	7.5.2	Overview of flat/tilted flow bed frame	38
6.0	Assembly of PR 600 starter and extension bays with pallet buffer, socketed stanchion, double-faced shelving with KDR flow bed frame	16	7.5.3	Overview of tilted flow bed frame	38
6.1	Upright profile	16	7.6	Assembly of the flow bed frame	39
6.2	Assembly of PR 600 starter and extension bays for frames P 73, P 93, P 95, P 13 or with X framework	16	7.7	Assembly of step cross connectors	41
6.2.1	Dimensions and parts list	17	7.8	Assembly of roller tracks, standard and retractable sashes	42
6.2.2	Assembly of frames P 73, P 93, P 95, P 13 or P 15 with X framework	17	7.9	Assembly of retractable sashes	44
6.3	Assembly of the socketed stanchion for frames P 73, P 93, P 95, P 13 or P 15 with X framework	18	7.10	Assembly of multiplex sashes and guide rails	45
6.3.1	Dimensions and parts list	19	8.0	Assembly of accessories	46
6.3.2	Assembly of socketed stanchion with frames P 73, P 93, P 95, P 13 or P 15	19	8.1	Assembly of braking strips	46
6.4	Assembly of PR 600 starter and extension bays for double-faced shelving with Z framework P 73, P 93, P 95	20	8.2	Assembly of braking clips	46
6.4.1	Dimensions and parts list	21	8.3	Assembly of expanding locks	46
6.4.2	Assembly of frames P 73, P 93, P 95, P 13 or P 15 with Z framework	23	8.4	Assembly of step beads	47
6.5	Assembly of the socketed stanchion for frames P 73, P 93, P 95, P 13 or P 15 with Z framework	24	8.5	Assembly of transport roller tracks	48
6.5.1	Dimensions and parts list	25	8.6	Assembly of installation tables	49
6.5.2	Assembly of socketed stanchion with frames P 73, P 93, P 95, P 13 or P 15	25	8.7	Assembly of upright adapters for third-party uprights, PR 300, PR 350, PR 400, PR 500 and LS 600	50
6.6	Floor anchoring	26	8.8	Assembly of angle protectors	50
			8.9	Assembly of mesh rear panels	51
			8.10	Assembly of end stops	51
			8.11	Bay load plate	51

2.0 Warnings

 **Attention!**
Failure to follow these instructions can result in injuries to persons or damage to equipment.

 **Please note!**
Provides additional usage tips and useful information.

 **Help required!**
Indicates that more than one person is required for setup. Failure to follow these instructions can result in personal injury or equipment damage.

3.0 Safety instructions / important information

 The SSI SCHAEFER shelving system has been manufactured in line with the latest technological standards and conforms to the relevant rules and regulations. However, this product could still represent a hazard to persons and equipment if:

- The shelving is not set up correctly.
- It is improperly modified or converted.
- Genuine accessory parts are not used.
- The safety regulations are not observed.

For this reason, each person involved in the assembly process must read and follow the safety instructions. Where appropriate, this must be confirmed with signatures.

The following also applies as a matter of course:

- Current accident prevention regulations.
- Generally recognised safety regulations.
- Country-specific regulations.
- When planning shelving systems, the guidelines for storage installations and devices in the relevant country must be observed.

 Please note the principles and instructions for setting up and using storage installations. If these are not available, please request the documentation.

The shelving installations are set up in temperature-controlled rooms enclosed on all sides (< 5°C). Load capacity information can be found in the relevant load tables.

Before starting installation work, commissioning or using the equipment, it is essential that the information contained in these instructions is observed to avoid hazards. If you require expert assistance, please contact us.

3.1 Shelving setup

 To avoid personal injury and material damage, please observe the following points:

- The current version of the BGR 234 guidelines for storage installations and equipment from the German Umbrella Organisation for Trade Associations (Hauptverband der gewerblichen Berufsgenossenschaften).
- The current workplace directives and regulations.
- Limit values for lifting and carrying loads.
- The instructions from your safety representative.
- The structural conditions and regulations, in particular also the design and load bearing capacity of the floor.
- That the equipment is in perfect condition. Damaged or misshapen components must be replaced immediately. In case of doubt, interrupt the assembly work, or use of the equipment, secure the setup area and inform your safety representative.

- The equipment must only be loaded after all installation work has been completed.
- That the direct storage of foodstuffs on zinc-plated shelf bases or panels is not permitted.
- That protective clothing such as helmet, gloves, safety shoes must be worn during setup and conversion.
- That the shelving is effectively protected against being hit by fork lift trucks or other vehicles.

All genuine SSI SCHAEFER construction components used to stabilise the storage equipment must be fitted without restriction. This includes primarily horizontal and cross braces, as well as floor dowels, screws/fixing components.

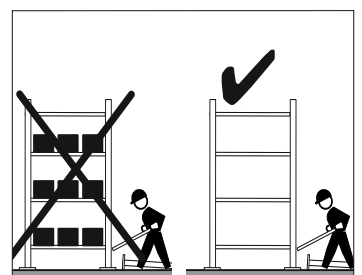
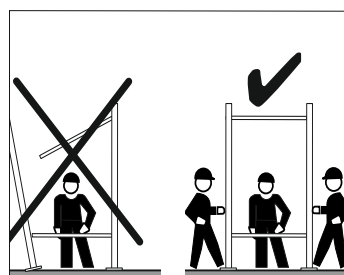

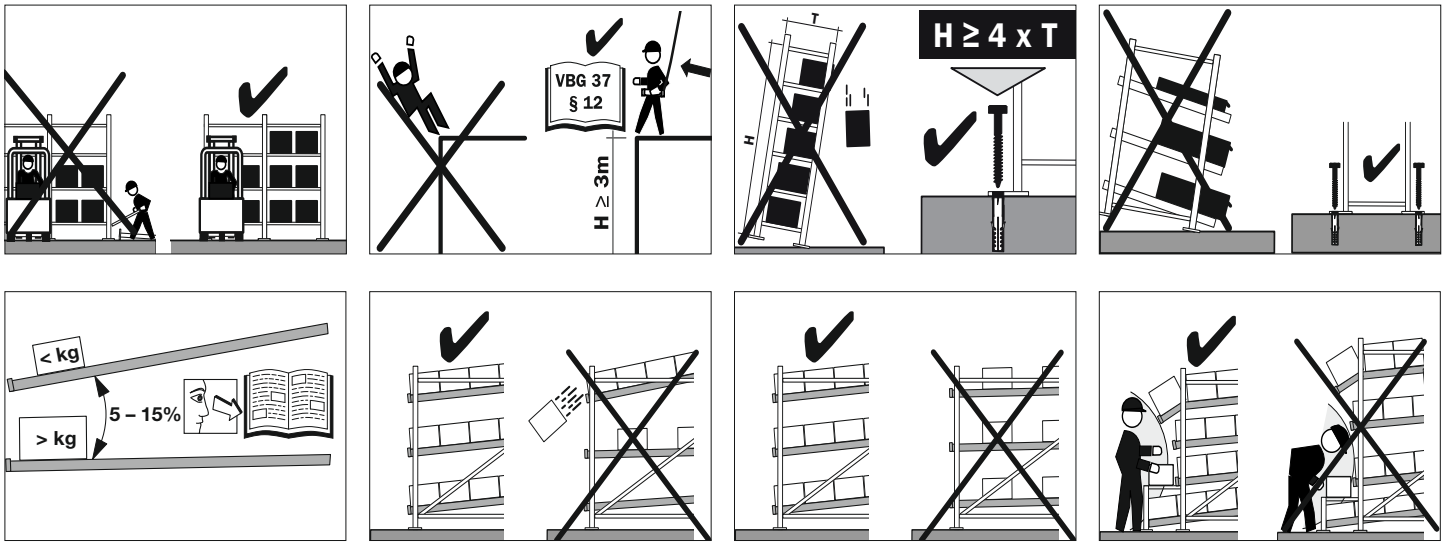

3.2 Checking the floor conditions for the shelving setup

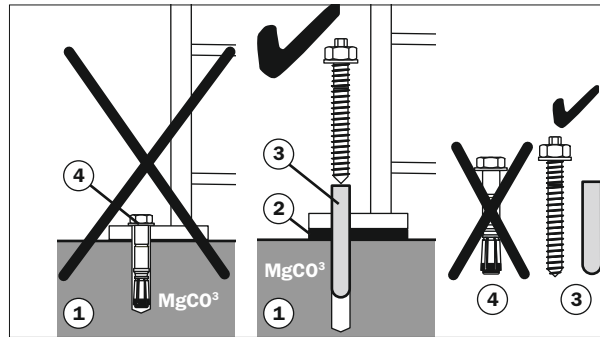
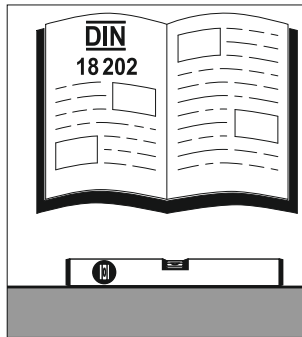
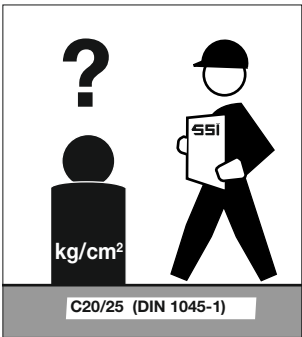

1. Magnesite screed
2. Insulating plate
3. Threaded anchors
4. Anchor bolts



Before setting up shelving installation, please check the following:

- That the load capacity of the floor is suitable for safely supporting the planned loads. In case of doubt, ask an expert and calculate the load capacity limits. The responsibility for these details being correct lies with the client.
- The evenness of the floor. It is the responsibility of the operator to observe the maximum loads specified by SSI SCHAEFER. The maximum load values given are based on uniformly distributed loads.
- The surface of the floor. The requirements are a reinforced concrete plate, min. 200 mm thick, concrete quality C20/25; DIN 1045/EC 2. With a surface finished with a magnesite screed, insulating plates are required to avoid corrosion and special anchor bolts. For any other floor conditions, please inform the manufacturer and provide proposals. For any other floor conditions, please inform the manufacturer and provide proposals.

3.3 Deviation from the vertical

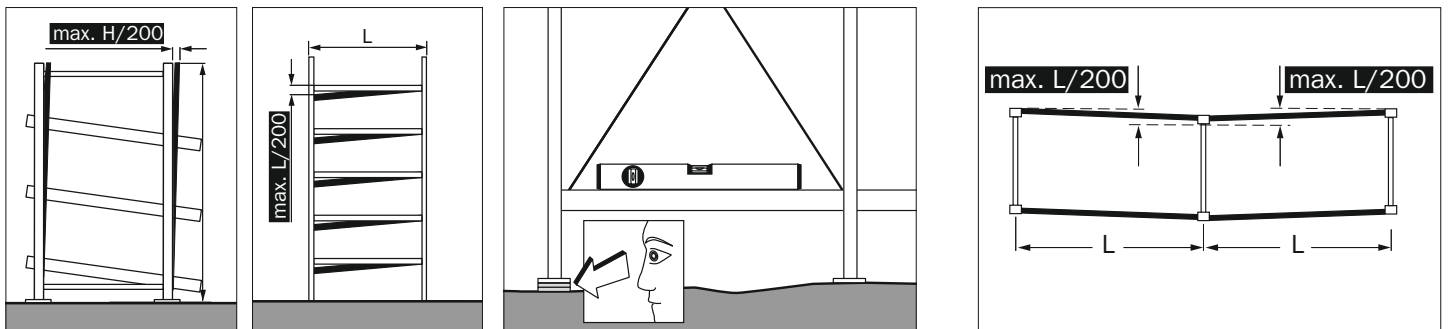

3.4 Operating and usage instructions

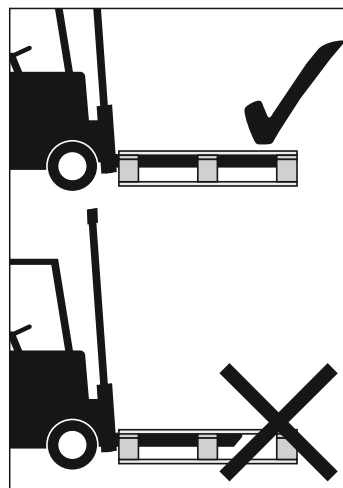
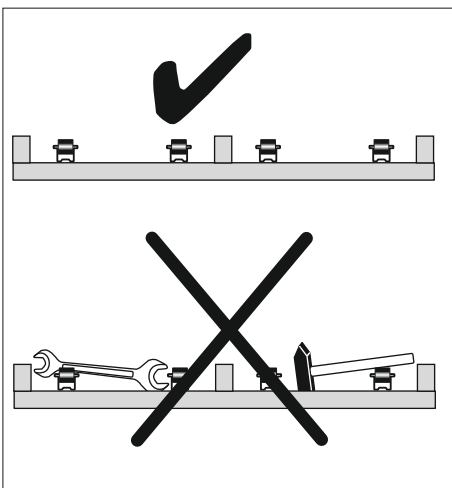
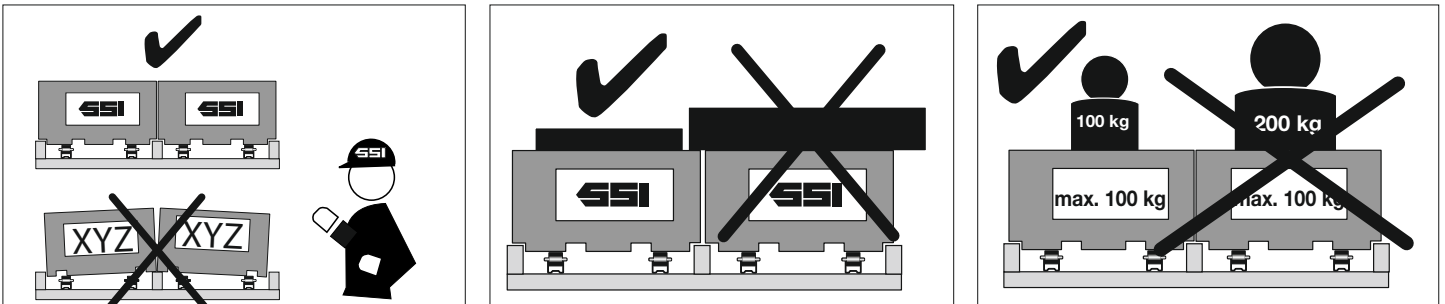
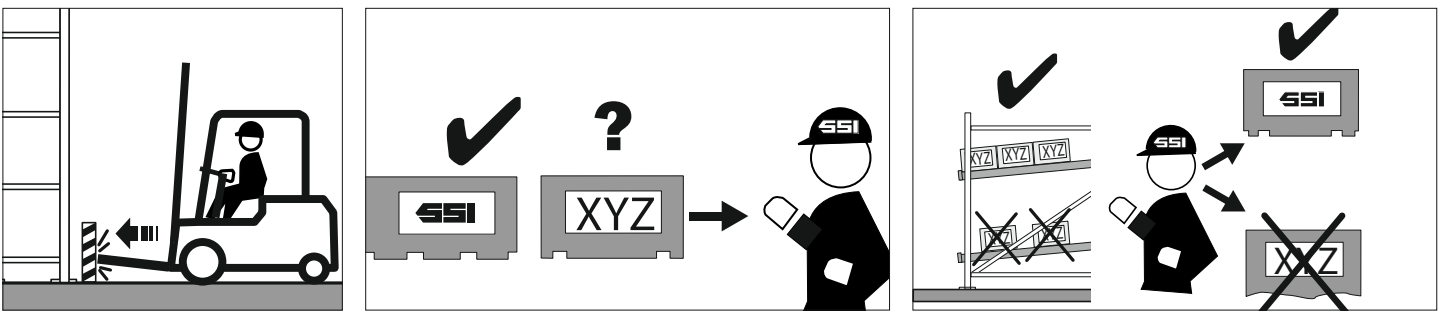
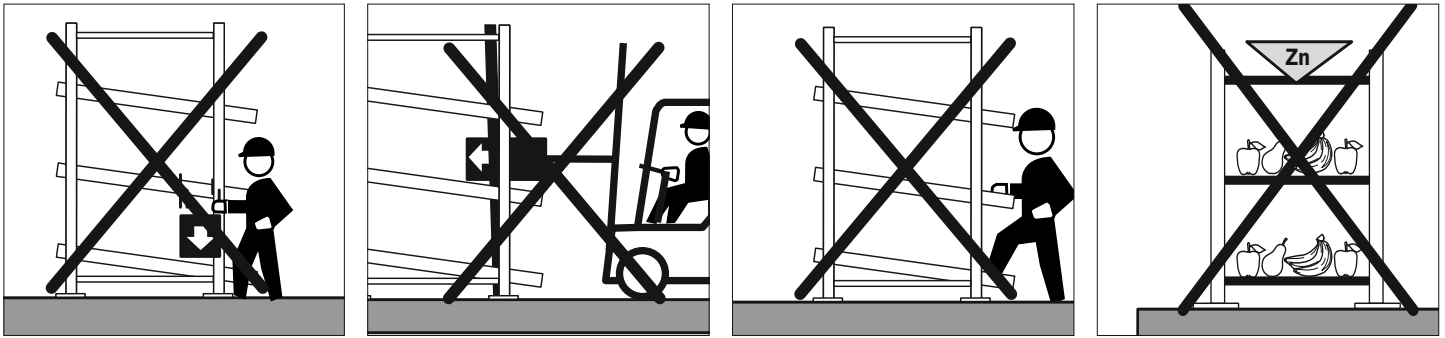
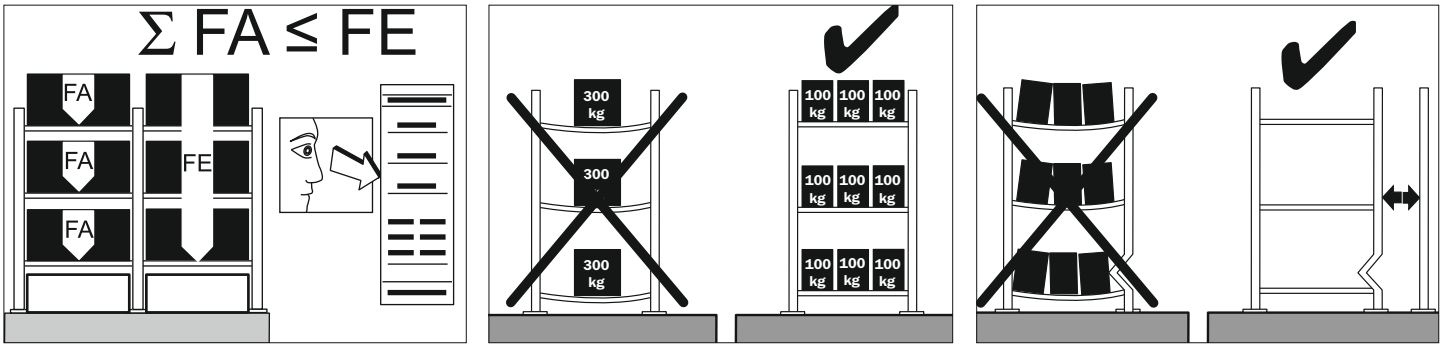

Instructions for fork lifts and pallets

The fork lift must have sufficiently long forks for the pallet depth. The forks should not extend over the pallet but must securely grip the last base board of the pallet. The reliable capacity of the pallets must not be exceeded.

Excess stock storage

The pallets must be fully in contact with the cross beams. The pallets must not be moved over the cross beams or deposited with force. Only Euro pallets that are in perfect condition and that conform to the quality requirements should be used. The shelf sides not intended for loading and unloading must be fitted with end frame extensions to prevent stored goods falling off. The user must ensure that the permissible load figures are observed.

4.0 Frame types

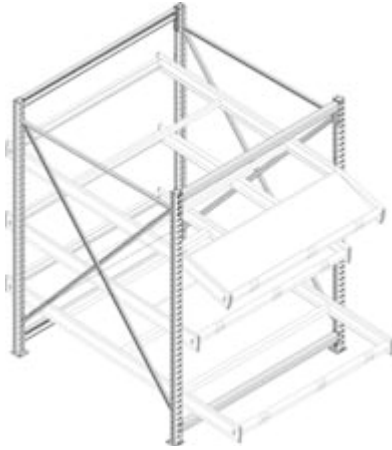

KDR – Stationary starter bay



KDR – Starter bay with undercarriage

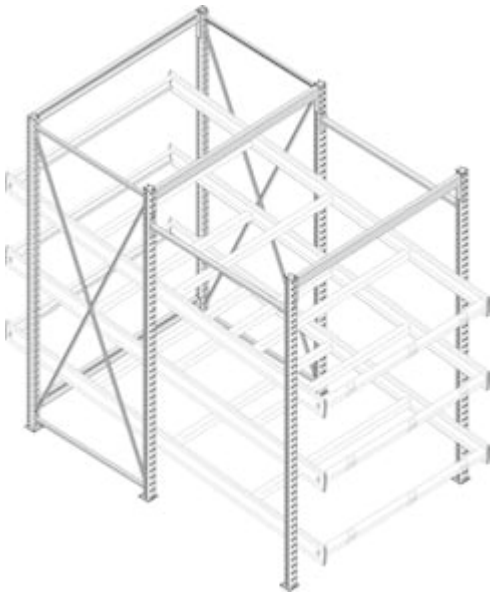

KDR – Starter bay with socketed stanchion

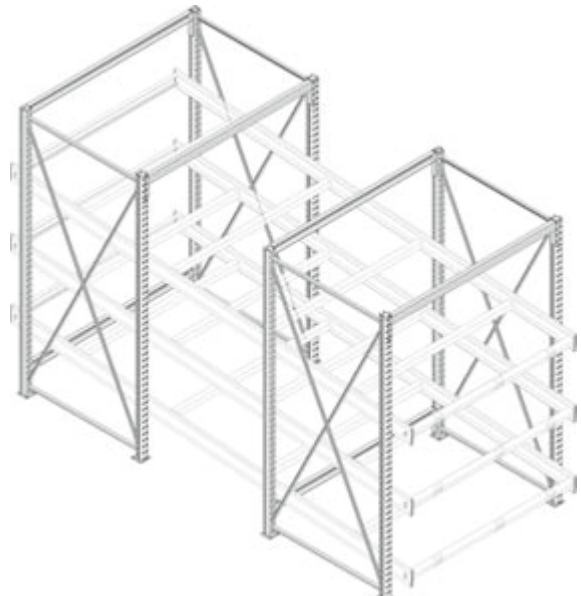

KDR – 2 starter bays one behind the other for large depths

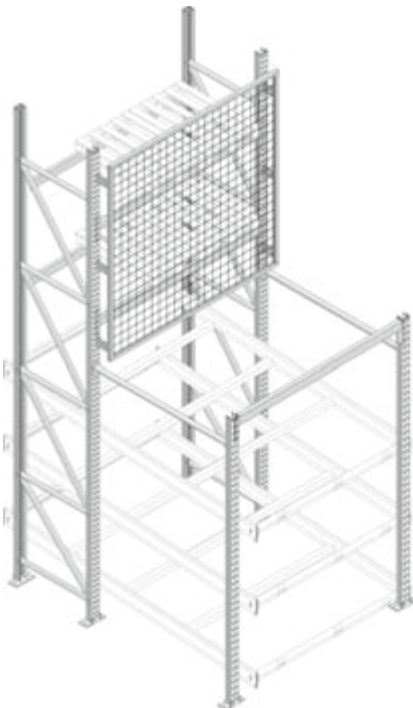

PR 600 – Starter bay with socketed stanchion, flow bed frame KDR and pallet buffer

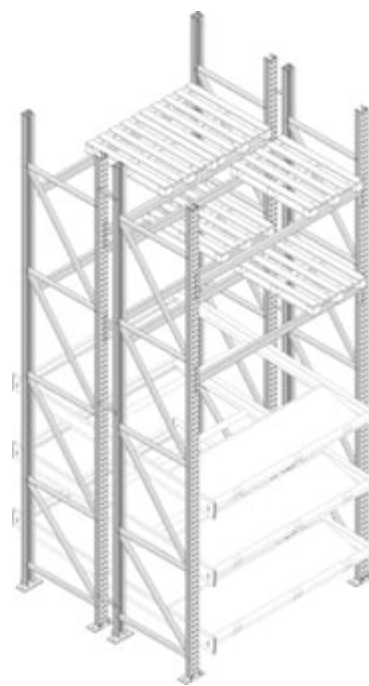

PR 600 – Double starter bay with flow bed frame KDR and pallet buffer

5.0 Assembly of KDR starter and extension bays, socketed stanchion, two frames one behind the other for large depths and starter bay with undercarriage

5.1 Upright profiles

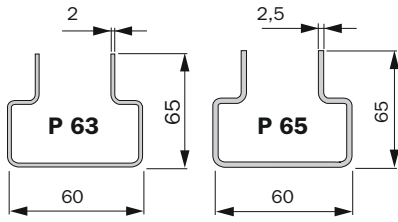

5.2 Assembly of KDR starter and extension bays for frames P 63 or P 65 with Z framework

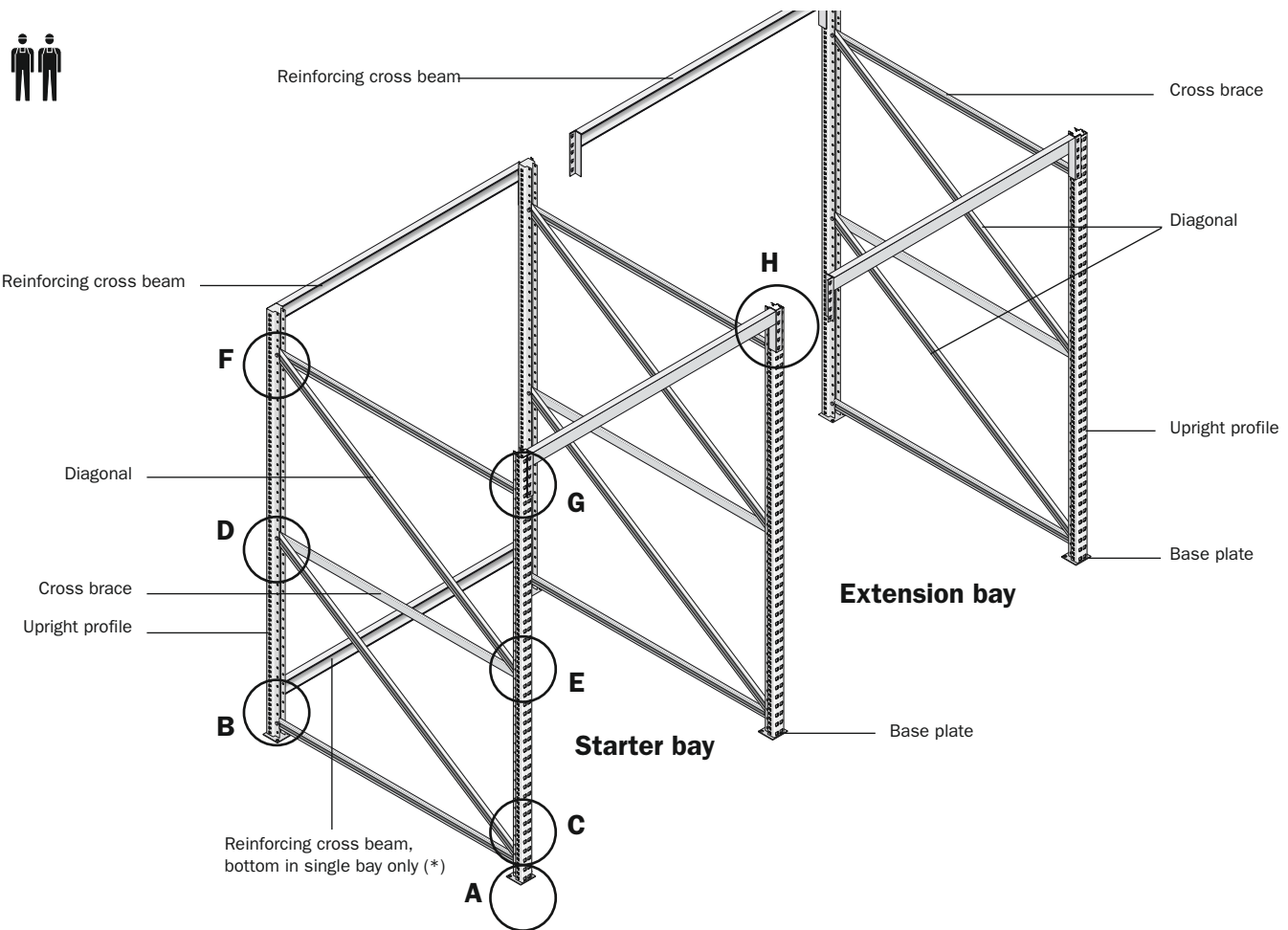

5.2.1 Dimensions and parts list

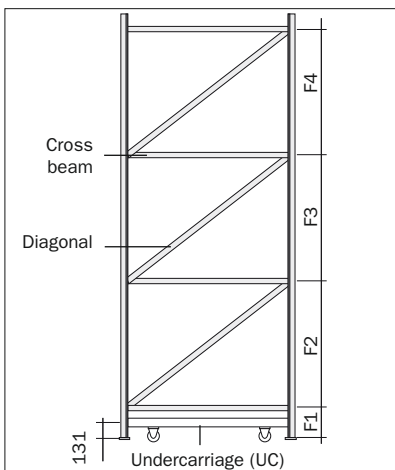

Assembly spacing of the Z frameworks for P 63 and P 65 frames							
Profile	Frame height mm	Framework height (F) mm				Frame depth mm	
		F1	F2	F3	F4	850	1.050
P 63 / P 65	1.600	81	950	450	-	✓	✓
	1.600 UC	381	950	-	-	-	✓
	1.800	181	950	450	-	✓	✓
	1.800 UC	181	950	450	-	-	✓
	2.000	281	950	450	-	✓	✓
	2.000 UC	131	950	450	-	-	✓
	2.200	181	950	950	-	✓	✓
	2.200 UC	181	950	950	-	-	✓
	2.500	281	950	950	-	✓	✓
	2.500 UC	281	950	950	-	-	✓
3.000	81	950	950	950	✓	✓	

Parts list for starter bay												
Support profile	Frame height	Upright profile	Diagonal	Cross brace	Reinforcing cross beam (*)	Screw M8 x 45 mm	Biloc nut (*) M8	Screw (*) M8 x 20 mm	Washer 8,4 (*)	Distance sleeve	Base plate	Under-carriage
P 63 / P 65	1.600	4	4	6	2/3	12	24/26	12/14	20/22	4	4	-
	1.600 UC	4	2	4	2	8	12	4	4	4	-	1
	1.800	4	4	6	2/3	12	24/26	12/14	20/22	4	4	-
	1.800 UC	4	4	4	2	10	12	4	4	4	-	1
	2.000	4	4	6	2/3	12	24/26	12/14	20/22	4	4	-
	2.000 UC	4	4	6	2	12	16	4	4	4	-	1
	2.200	4	4	6	2/3	12	24/26	12/14	20/22	4	4	-
	2.200 UC	4	4	4	2	10	14	4	4	4	-	1
	2.500	4	4	6	2/3	12	24/26	12/14	20/22	4	4	-
	2.500 UC	4	4	6	2	12	16	4	4	4	-	1
3.000	4	6	8	2/3	16	28/30	12/14	20/22	4	4	-	

Parts list for extension bay												
Support profile	Frame height	Upright profile	Diagonal	Cross brace	Reinforcing cross beam	Screw M8 x 45 mm	Biloc nut M8	Screw (*) M8 x 20 mm	Washer 8,4	Distance sleeve	Base plate	Under-carriage
P 63 / P 65	1.600	2	2	3	2	6	14	8	12	2	2	-
	1.800	2	2	3	2	6	14	8	12	2	2	-
	2.000	2	2	3	2	6	14	8	12	2	2	-
	2.200	2	2	3	2	6	14	8	12	2	2	-
	2.500	2	2	3	2	6	14	8	12	2	2	-
	3.000	2	3	4	2	8	16	8	12	2	2	-

5.2.2 Assembly of frames P 63 or P 65 with Z framework

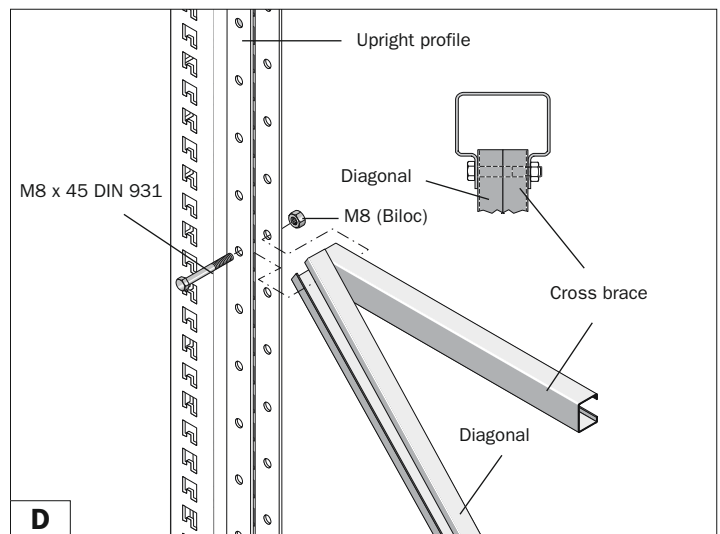
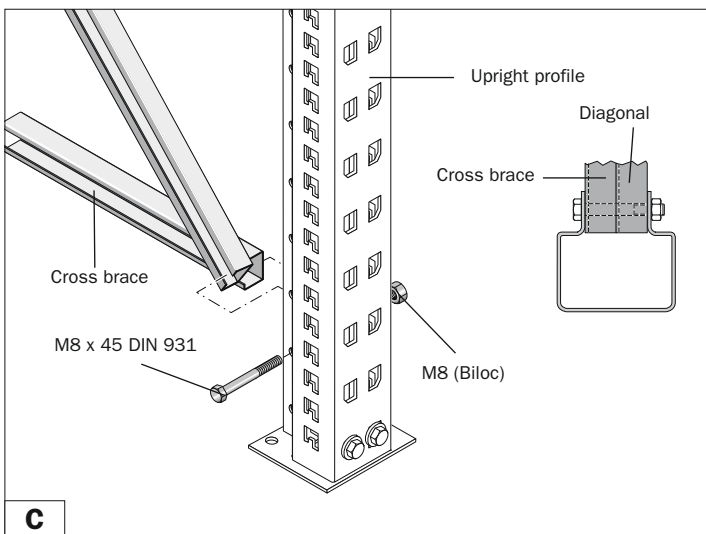
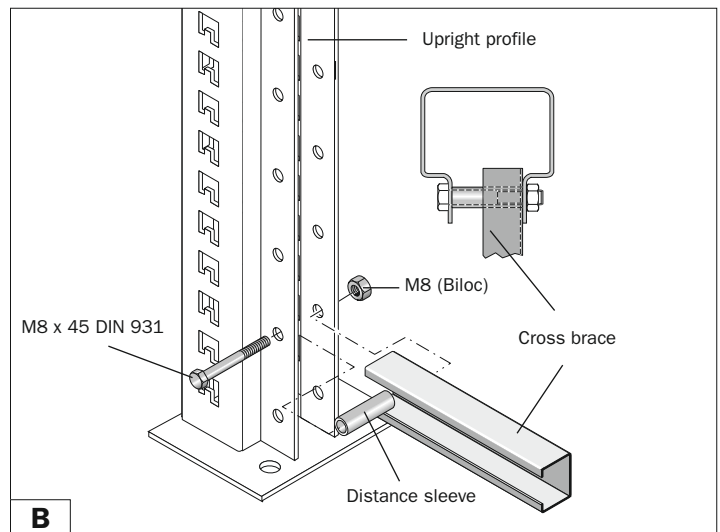
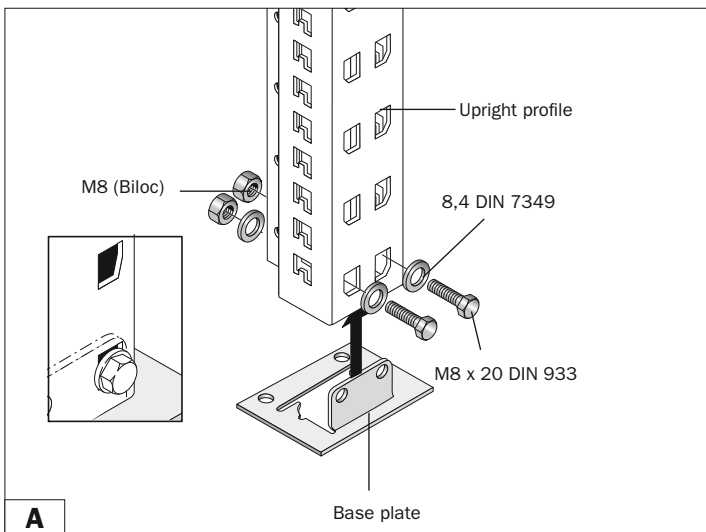

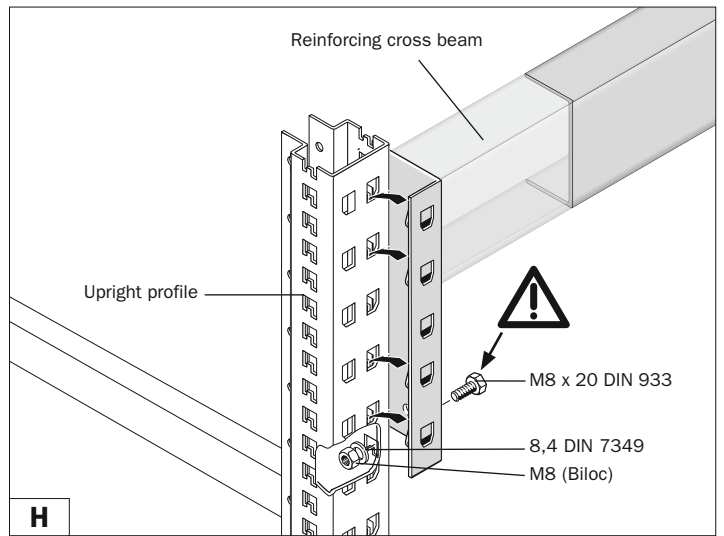
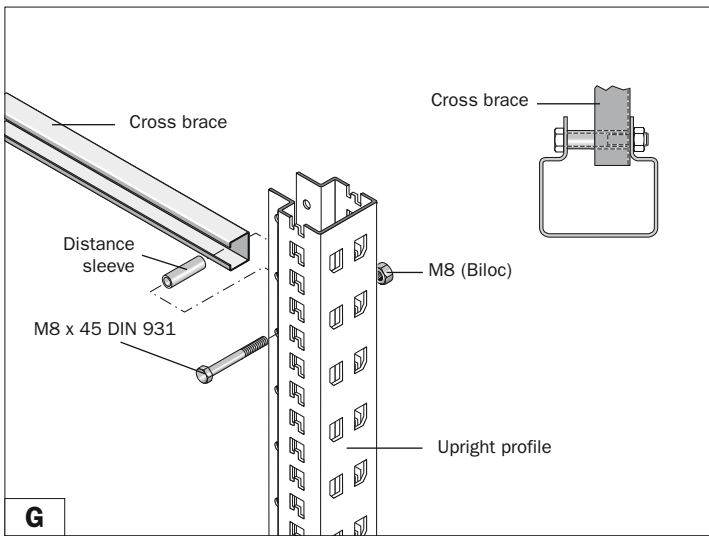
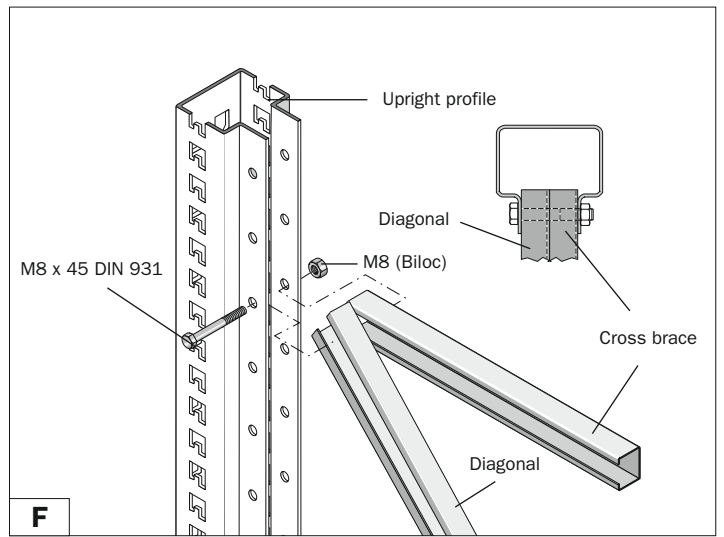
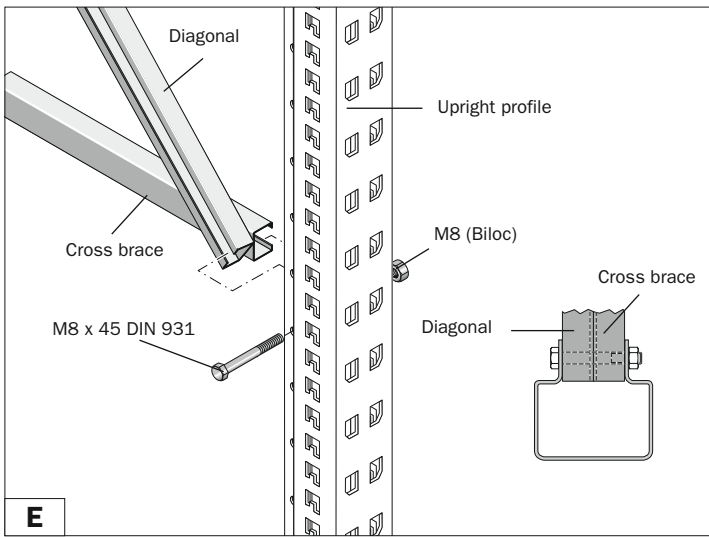

5.3 Assembly of KDR starter and extension bays for frames P 63 or P 65 with X framework

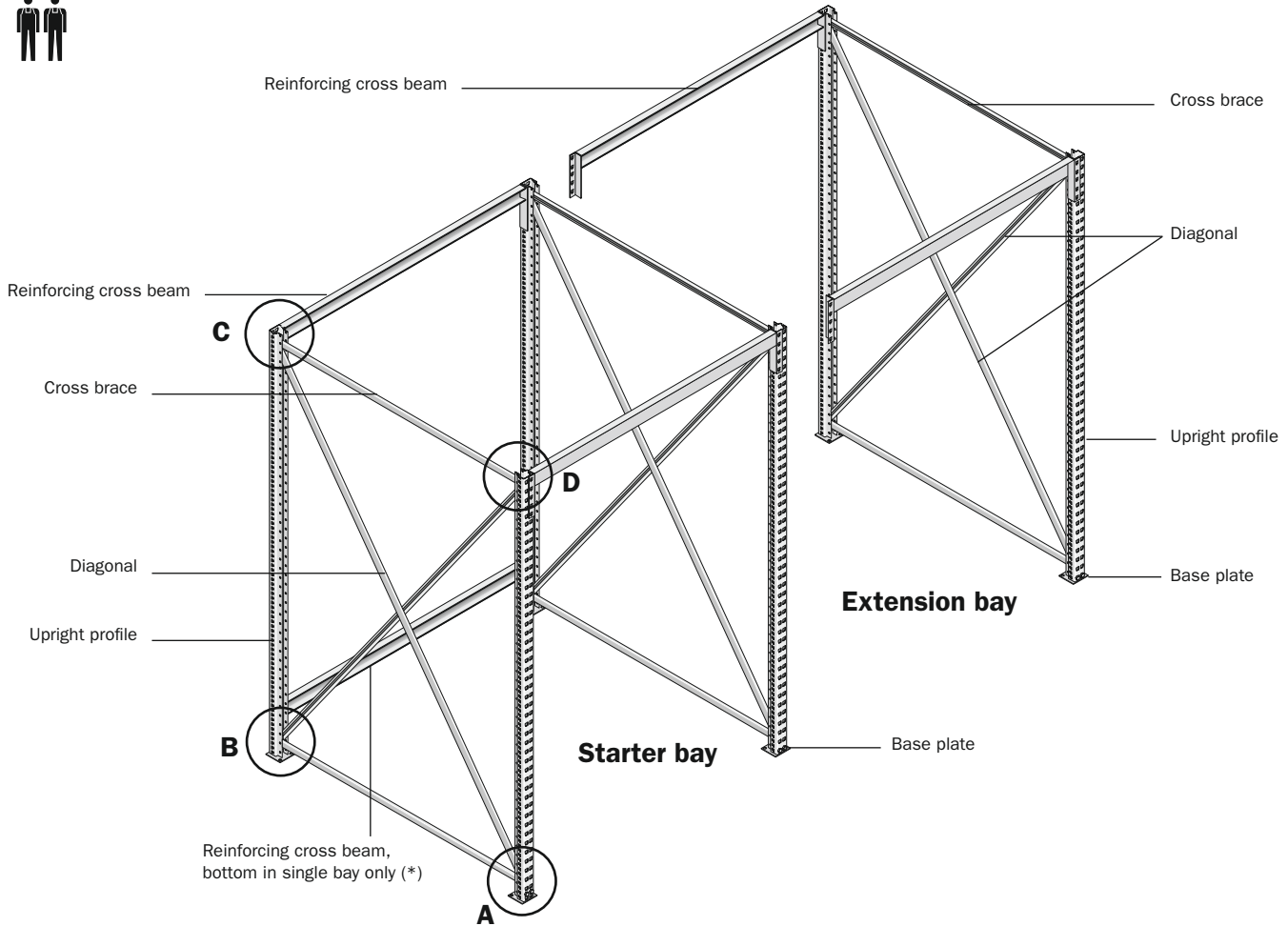

5.3.1 Dimensions and parts list

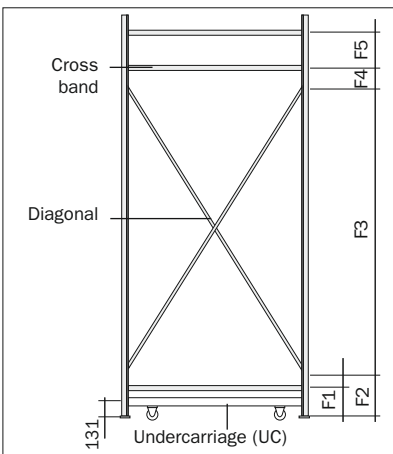

Assembly distances for the X framework (frame type 2)											
Profile	Frame height mm	Framework height (F) mm					Frame depth mm				
		F 1	F 2	F 3	F 4	F 5	1.250	1.450	1.650	2.050	2.650
P 63 / P 65	1.600	81	131	1.300	50	-	✓	-	✓	✓	✓
	1.600 UC	-	181	1.300	50	-	✓	-	✓	✓	-
	1.800	181	231	1.300	50	-	✓	-	✓	✓	✓
	1.800 UC	-	231	1.300	50	-	✓	-	✓	✓	-
	2.000	281	331	1.300	50	-	✓	-	✓	✓	✓
	2.000 UC	281	331	1.300	50	-	✓	-	✓	✓	-
	2.200	81	131	1.900	50	-	✓	-	✓	✓	✓
	2.200 UC	-	181	1.900	50	-	✓	-	✓	✓	-
	2.500	81	131	2.200	50	-	✓	-	✓	✓	✓
	2.500 UC	-	181	2.200	50	-	✓	-	✓	✓	-
3.000	81	131	2.200	50	500	✓	-	✓	✓	✓	

Parts list for starter bay												
Profile	Frame height	Upright profile	Diagonal	Cross brace	Reinforcing cross beams (*)	Screw M8 x 45 mm	Biloc nut (*) M8	Screw (*) M8 x 20 mm	Washer 8,4 (*)	Distance sleeve	Base plate	Under-carriage
P 63 / P 65	1.600	4	4	4	2/3	16	28/30	12/14	20/22	8	4	-
	1.600 UC	4	4	2	2	12	16	4	4	8	-	1
	1.800	4	4	4	2/3	16	28/30	12/14	20/22	8	4	-
	1.800 UC	4	4	2	2	12	16	4	4	8	-	1
	2.000	4	4	4	2/3	16	28/30	12/14	20/22	8	4	-
	2.000 UC	4	4	4	2	16	20	4	4	8	-	1
	2.200	4	4	4	2/3	16	28/30	12/14	20/22	8	4	-
	2.200 UC	4	4	2	2	12	16	4	4	8	-	1
	2.500	4	4	4	2/3	16	28/30	12/14	20/22	8	4	-
	2.500 UC	4	4	2	2	12	16	4	4	8	-	1
3.000	4	4	6	2/3	20	32/34	12/14	20/22	8	4	-	

Parts list for extension bay												
Profile	Frame height	Upright profile	Diagonal	Cross brace	Reinforcing cross beams (*)	Screw M8 x 45 mm	Biloc nut M8	Screw M8 x 20 mm	Washer 8,4	Distance sleeve	Base plate	Under-carriage
P 63 / P 65	1.600	2	2	2	2	8	24	8	12	4	2	-
	1.800	2	2	2	2	8	24	8	12	4	2	-
	2.000	2	2	2	2	8	24	8	12	4	2	-
	2.200	2	2	2	2	8	24	8	12	4	2	-
	2.500	2	2	2	2	8	24	8	12	4	2	-
	3.000	2	2	3	2	10	28	8	12	4	2	-

5.3.2 Assembly of frames P 63 or P 65 with X framework

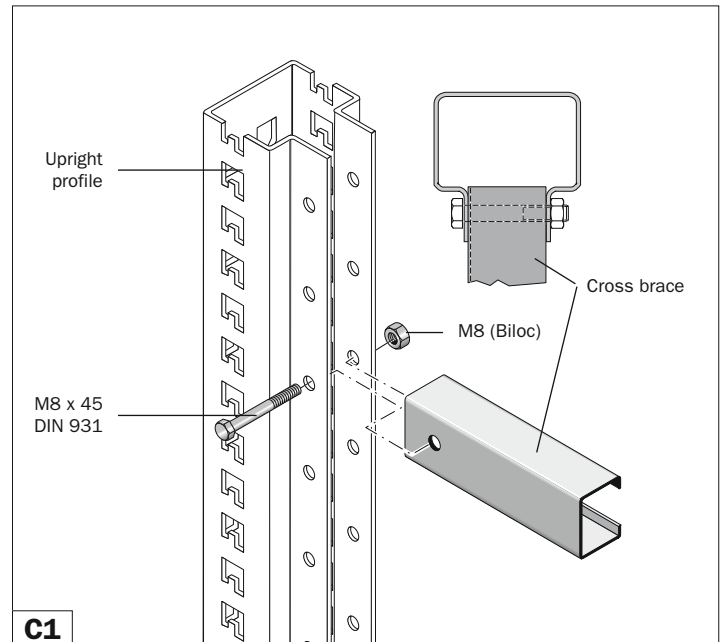
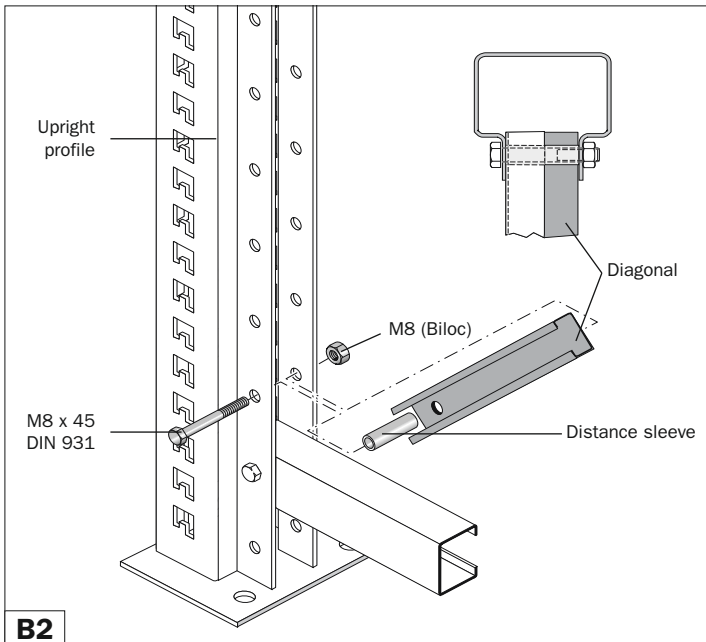
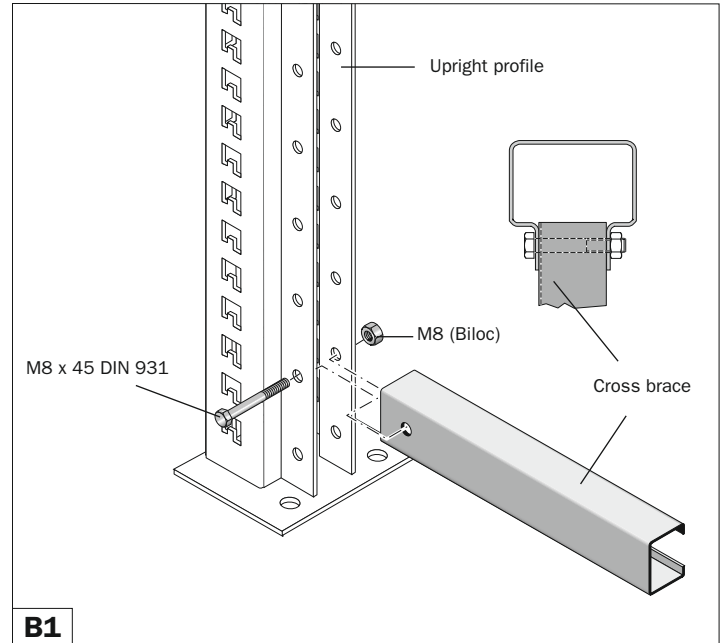
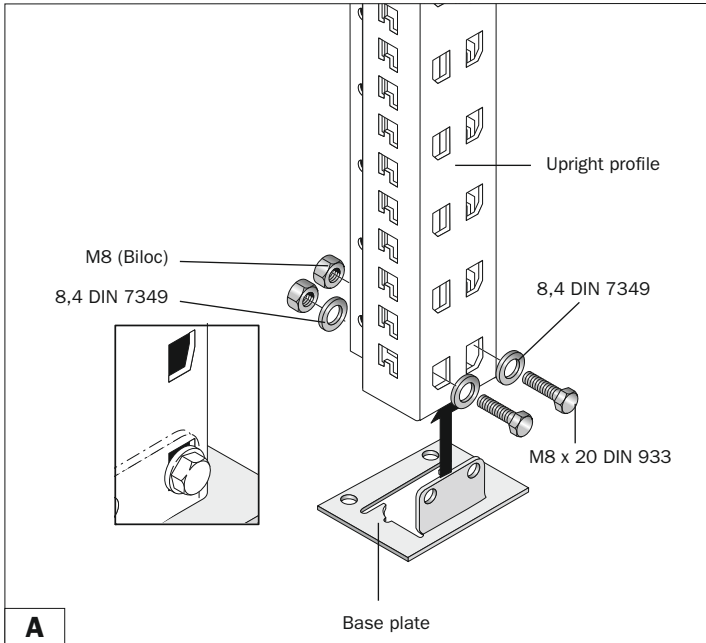

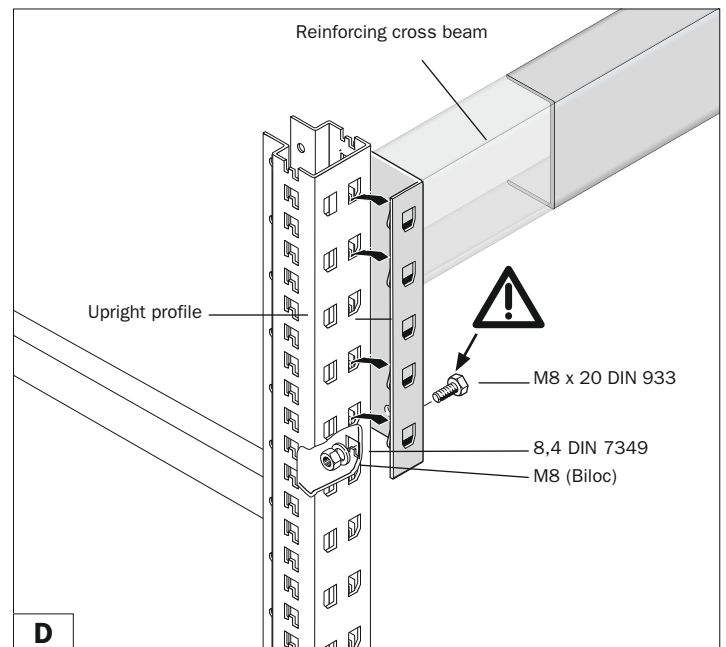
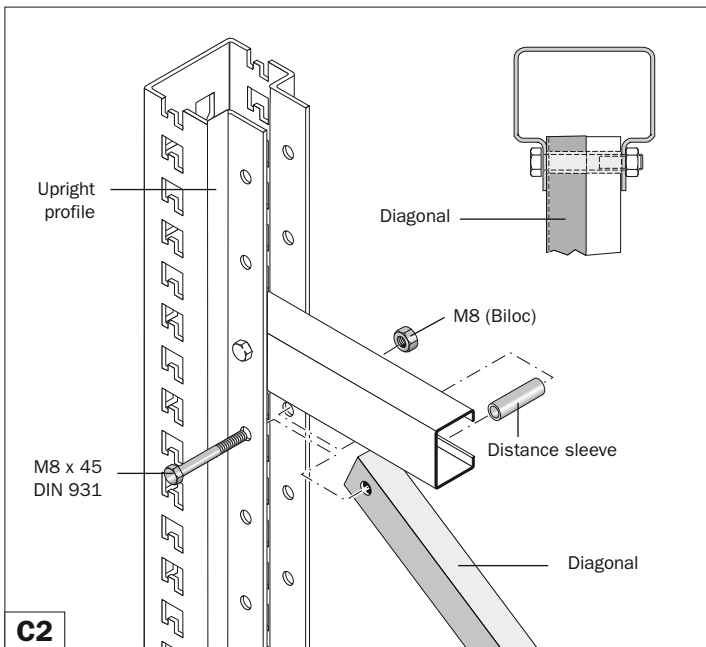

5.4 Assembly of socketed stanchion for frames P 63 or P 65 with X or Z framework

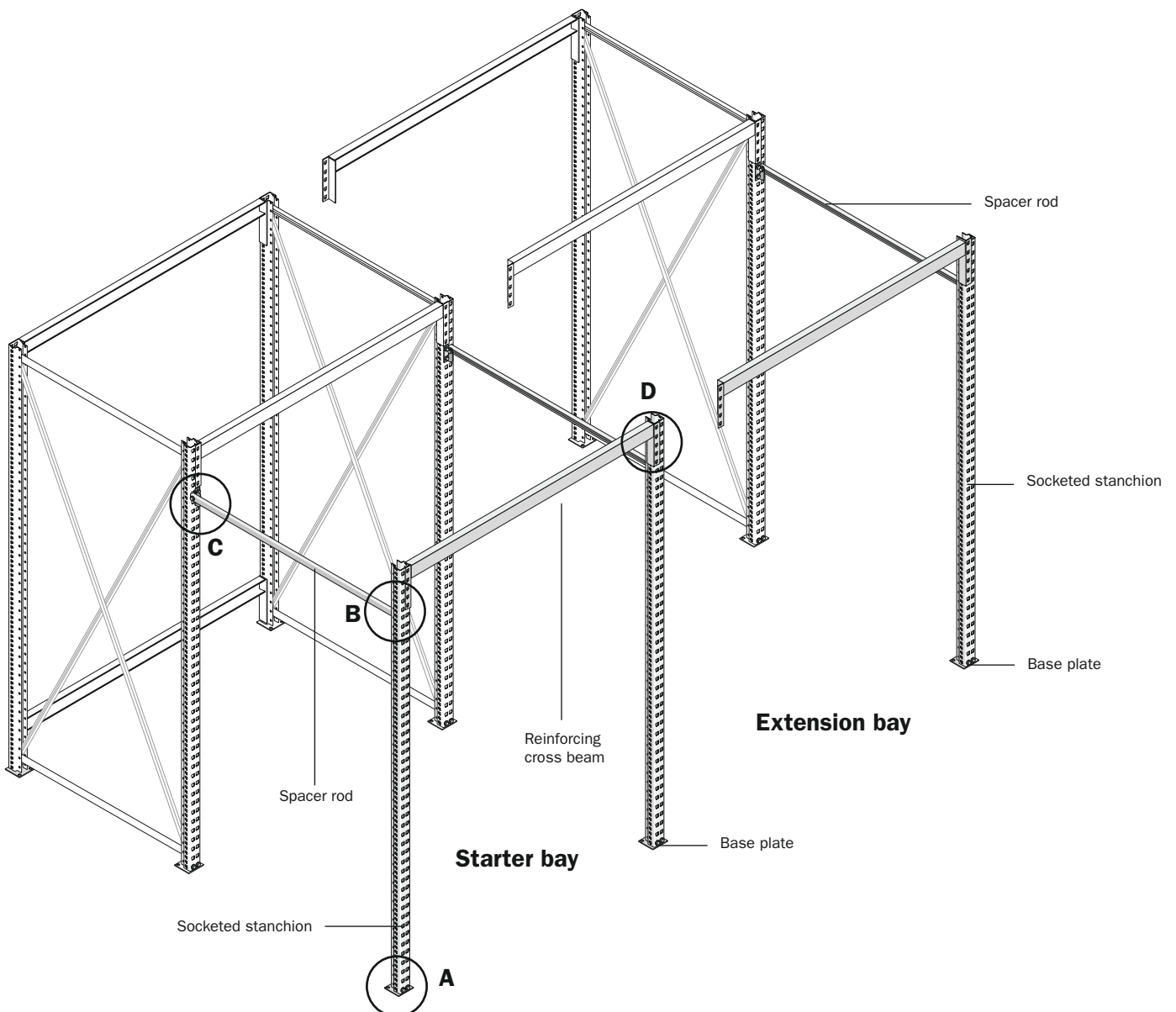

5.4.1 Dimensions and parts list

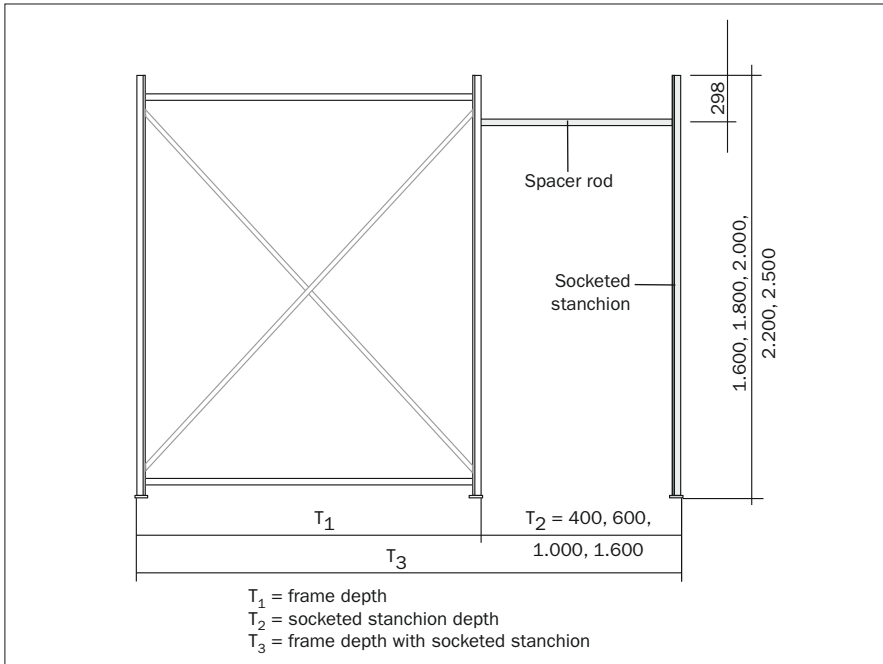

Parts list for starter bay

Profile	Frame height	Socketed stanchion	Spacer rod	Reinforcing cross beam	Screw M8 x 45 mm	Screw M8 x 30 mm	Screw M8 x 20 mm	Washer 8,4	Biloc nut M8	Distance sleeve	Base plate
P 63 / P 65	1.600	2	2	1	2	2	10	16	14	2	2
	1.800	2	2	1	2	2	10	16	14	2	2
	2.000	2	2	1	2	2	10	16	14	2	2
	2.200	2	2	1	2	2	10	16	14	2	2
	2.500	2	2	1	2	2	10	16	12	2	2
	3.000	2	2	1	2	2	10	16	12	2	2

Parts list for extension bay

Profile	Frame height	Socketed stanchion	Spacer rod	Reinforcing cross beam	Screw M8 x 45 mm	Screw M8 x 30 mm	Screw M8 x 20 mm	Washer 8,4	Biloc nut M8	Distance sleeve	Base plate
P 63 / P 65	1.600	1	1	1	1	1	6	8	8	1	1
	1.800	1	1	1	1	1	6	8	8	1	1
	2.000	1	1	1	1	1	6	8	8	1	1
	2.200	1	1	1	1	1	6	8	8	1	1
	2.500	1	1	1	1	1	6	8	8	1	1
	3.000	1	1	1	1	1	6	8	8	1	1

5.4.2 Assembly of the socketed stanchion with frames P 63 and P 65

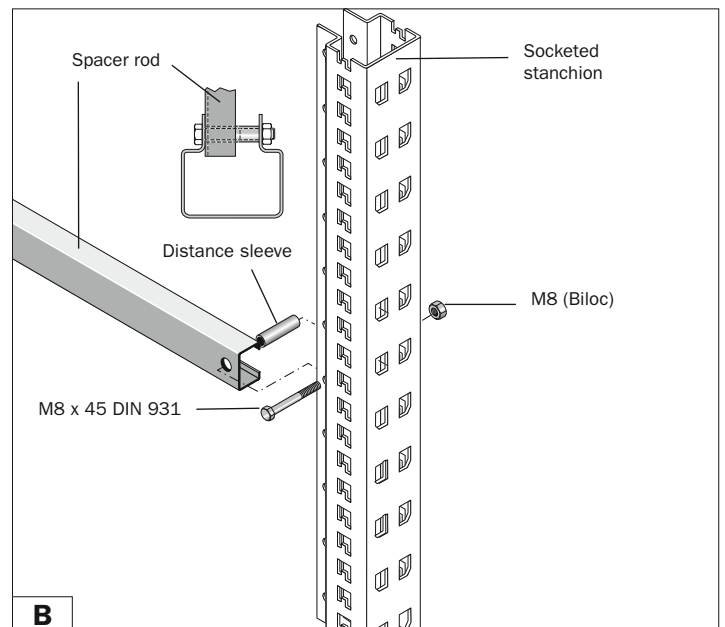
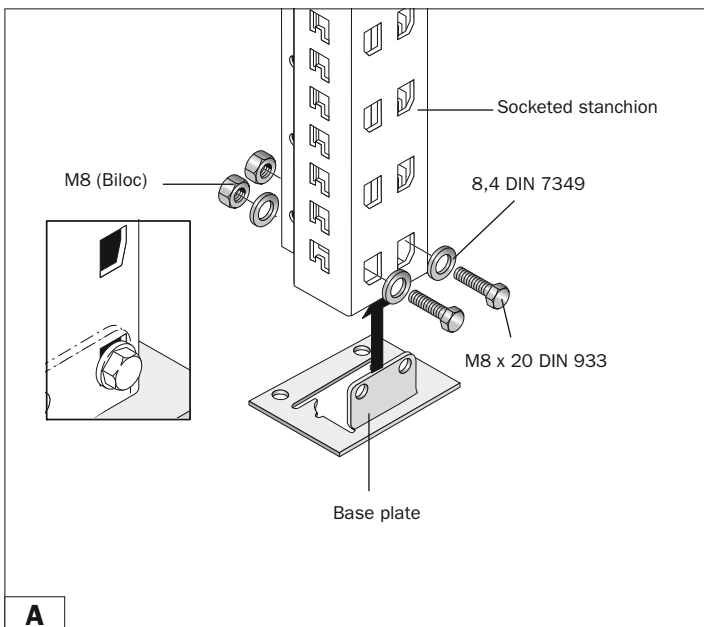

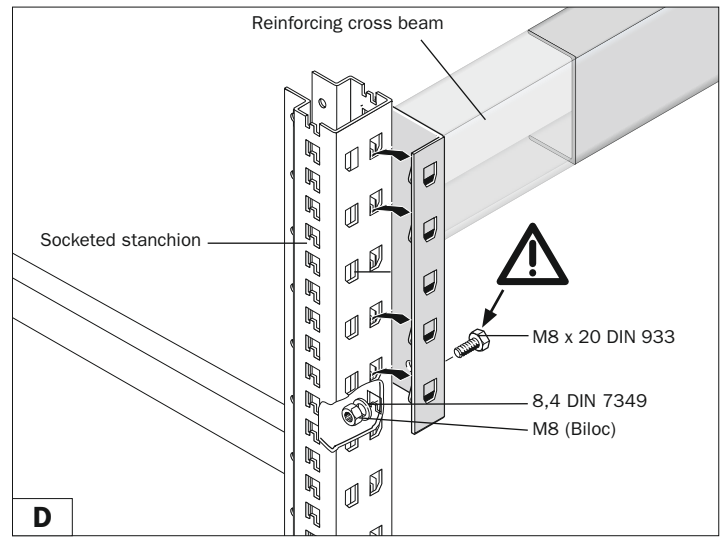
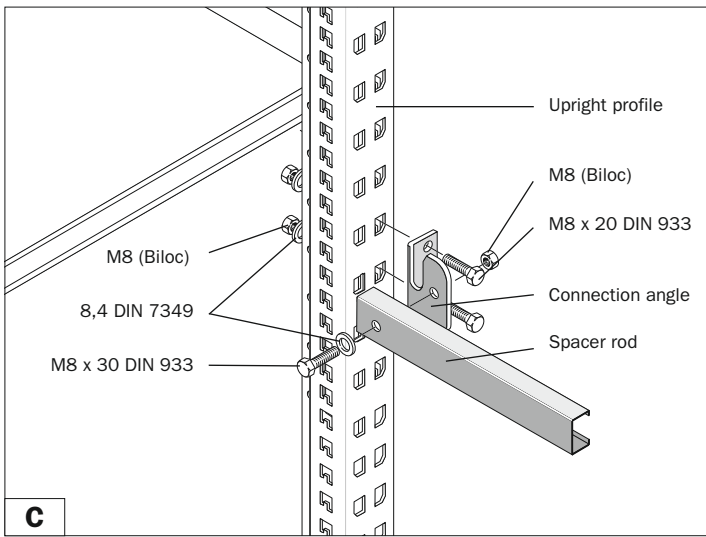

5.5 Floor anchoring

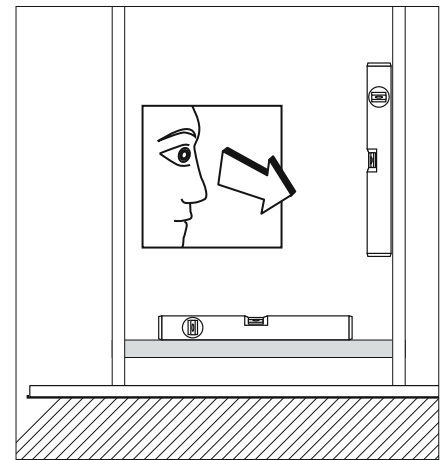
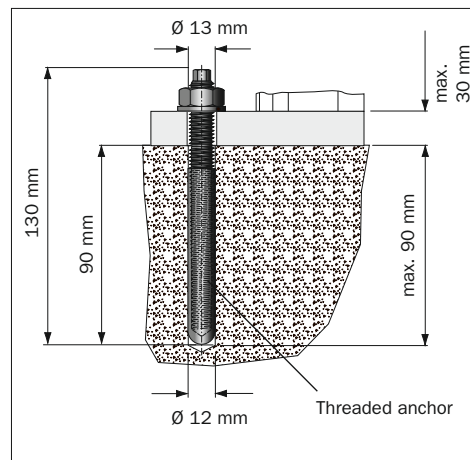
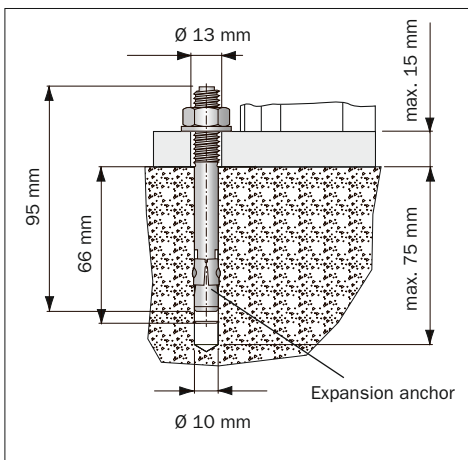

5.6 Undercarriage assembly

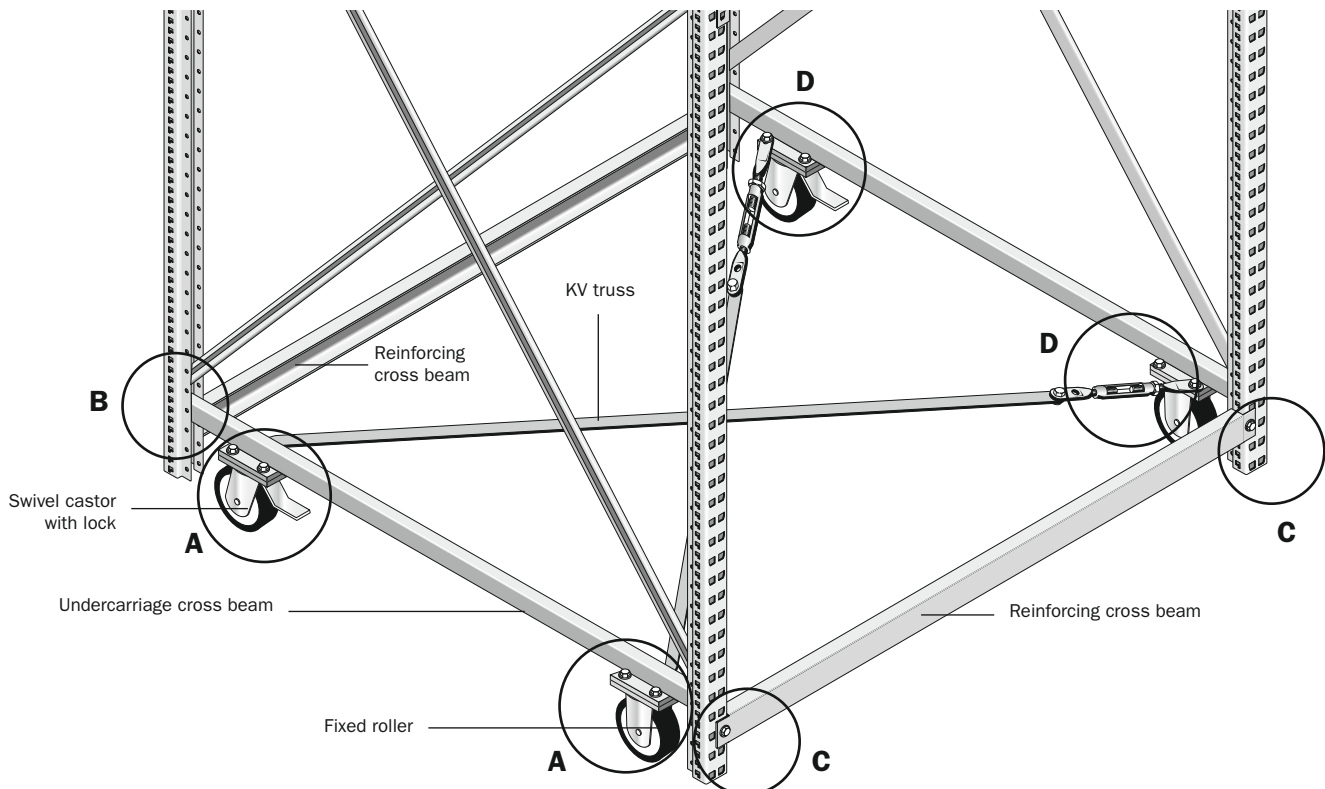

Parts list

Under-carriage cross beam	Reinforcing cross beam	KV truss	Swivel castor	Fixed roller	Swivel	Screw M8 x 20 mm	Screw M8 x 30 mm	Screw M8 x 25 mm	Screw M8 x 45 mm	Washer 8,4	Biloc nut M8	Verbus nut M8	Screw M10 x 20 mm	Nut M10	Washer 10,5
2	2	2	2	2	2	4	4	12	4	16	8	16	2	2	2

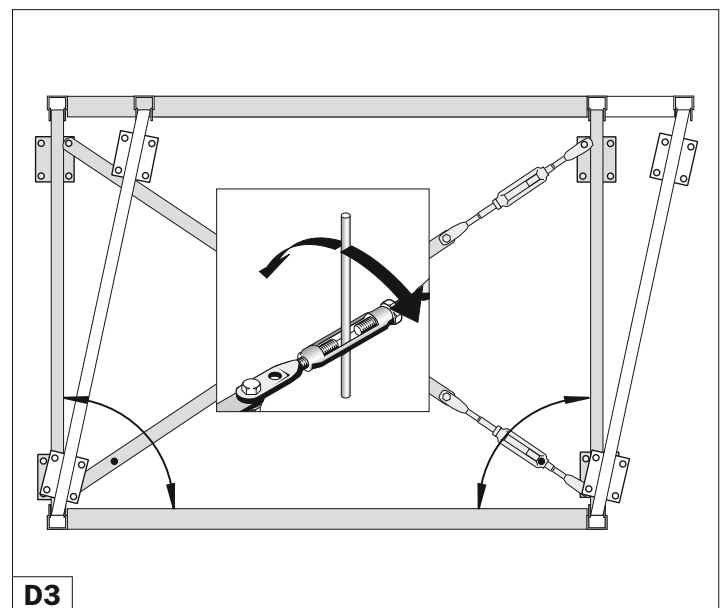
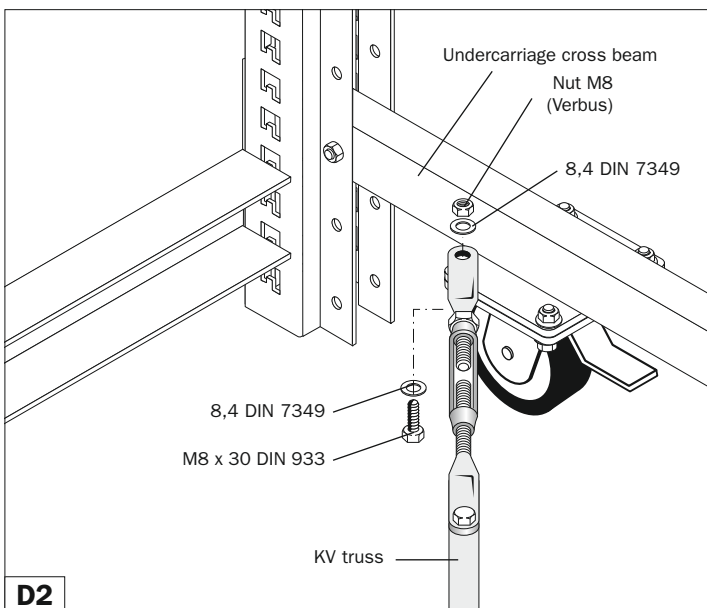
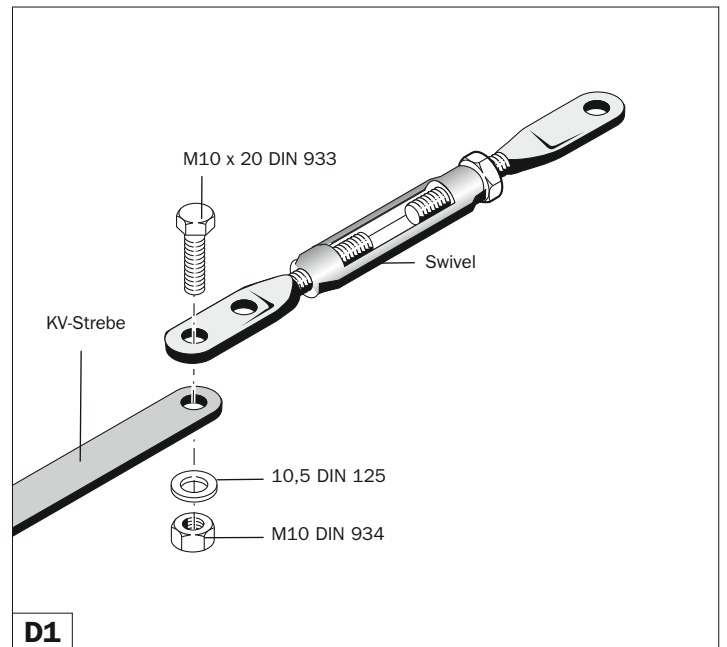
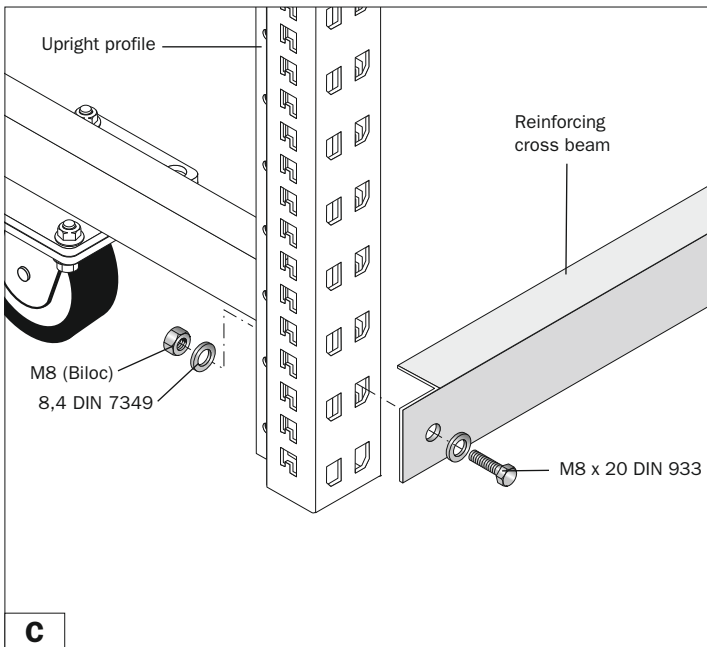
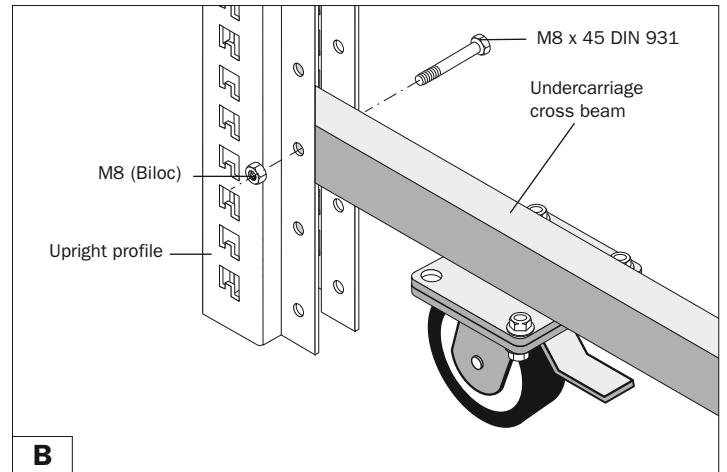
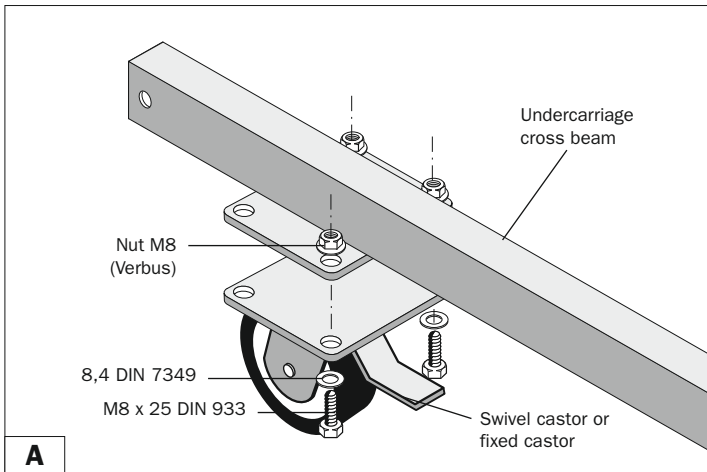

6.0 Assembly of PR 600 starter and extension bays with pallet buffer, socketed stanchion, double-faced shelving with KDR flow bed frame

6.1 Upright profile

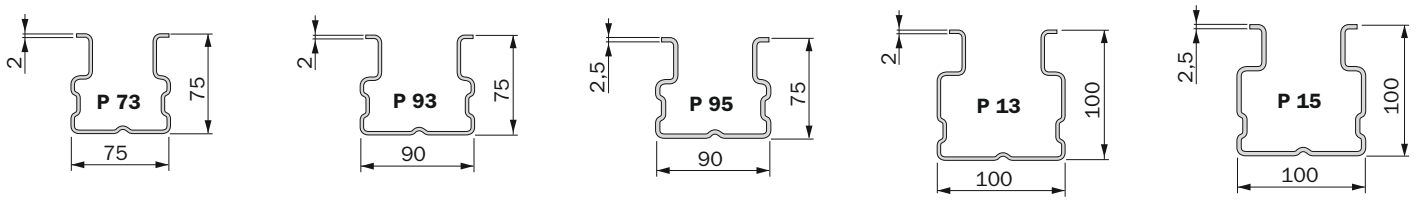

6.2 Assembly of PR 600 starter and extension bays for frames P 73, P 93, P 95, P 13 or P 15 with X framework

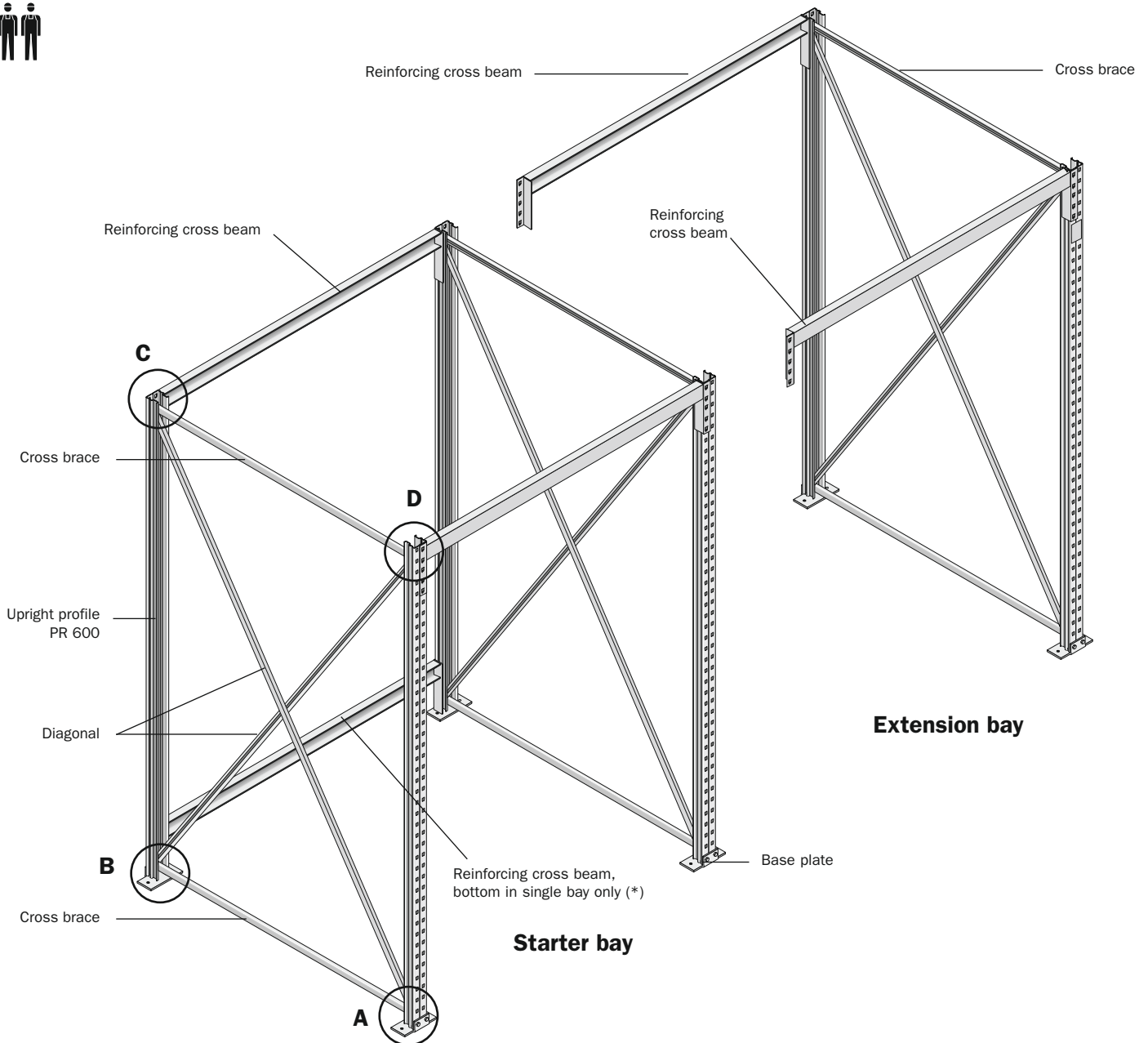

6.2.1 Dimensions and parts list

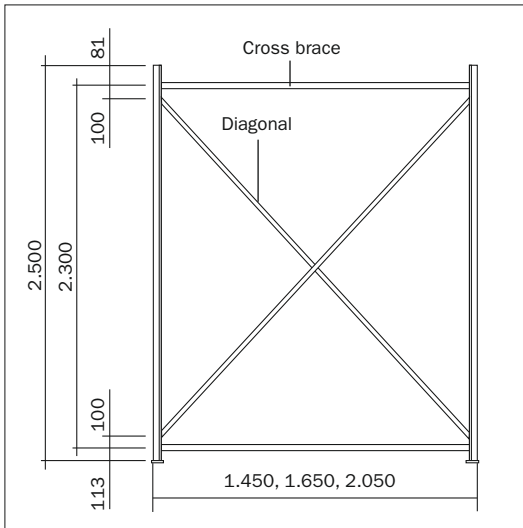

Parts list for starter bay

Upright profile	Diagonal	Cross brace	Reinforcing cross beams (*)	Screw M10 x 65 mm, M10 x 75 mm	Screw M10 x 30 mm	Biloc nut M10	Washer 10,5	Screw (*) M8 x 20 mm	Biloc nut M8 (*)	Washer 8,4 (*)	Distance sleeve	Base plate
4	4	4	2/3	16	8	24	16	4/6	4/6	4/6	8	4

Parts list for extension bay

Upright profile	Diagonal	Cross brace	Reinforcing cross beams	Screw M10 x 65 mm, M10 x 75 mm	Screw M10 x 30 mm	Biloc nut M10	Washer 10,4	Screw M8 x 20 mm	Biloc nut M8	Washer 8,4	Distance sleeve	Base plate
2	2	2	2	8	4	12	8	4	4	4	4	2

6.2.2 Assembly of frames P 73, P 93, P 95, P 13 or P 15 with X framework

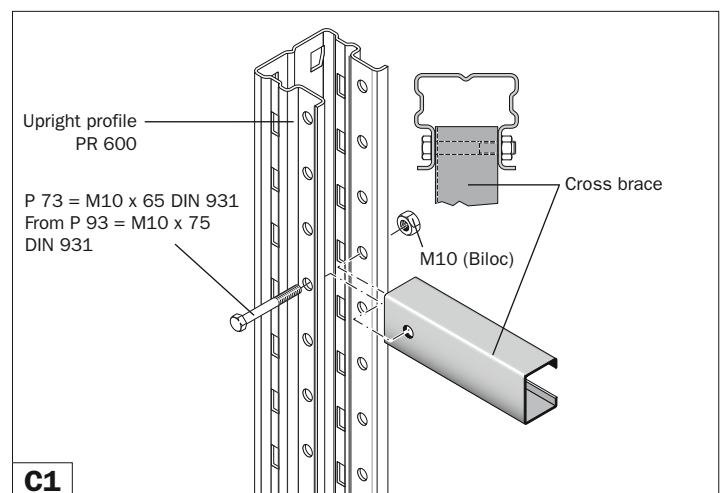
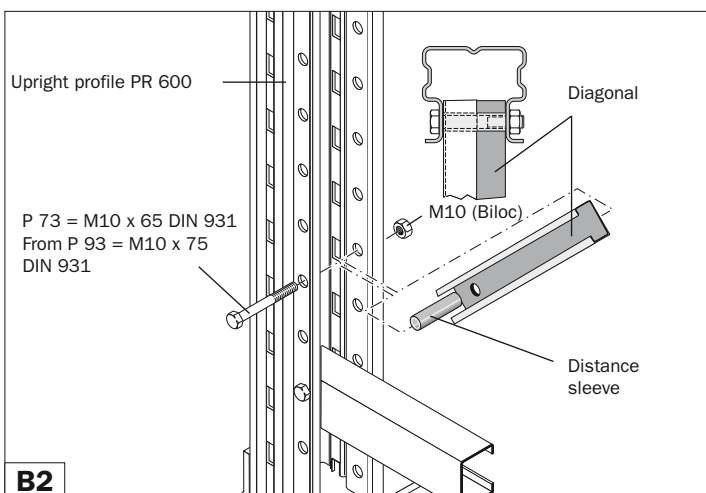
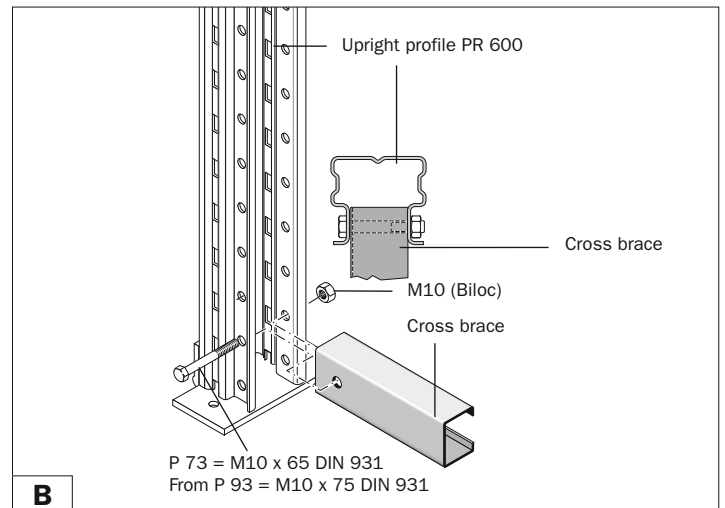
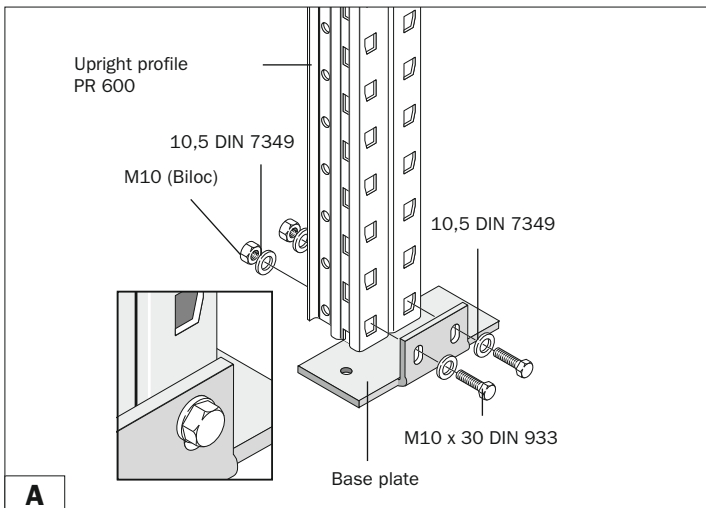

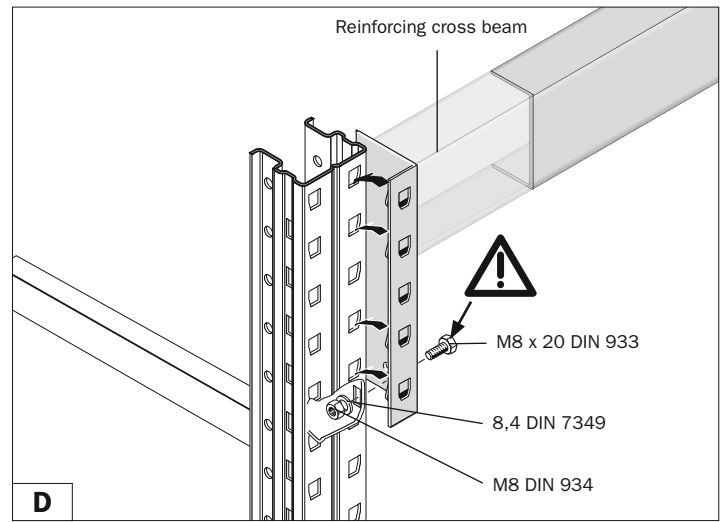
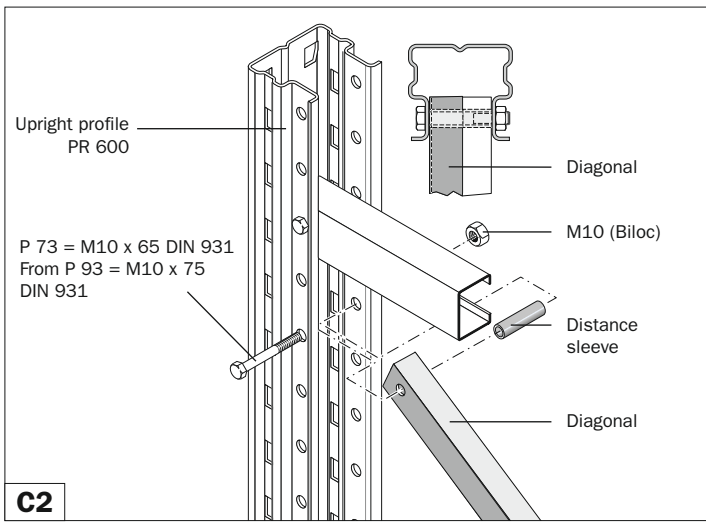

6.3. Assembly of the socketed stanchion for frames P 73, P 93, P 95, P 13 or P 15 with X framework

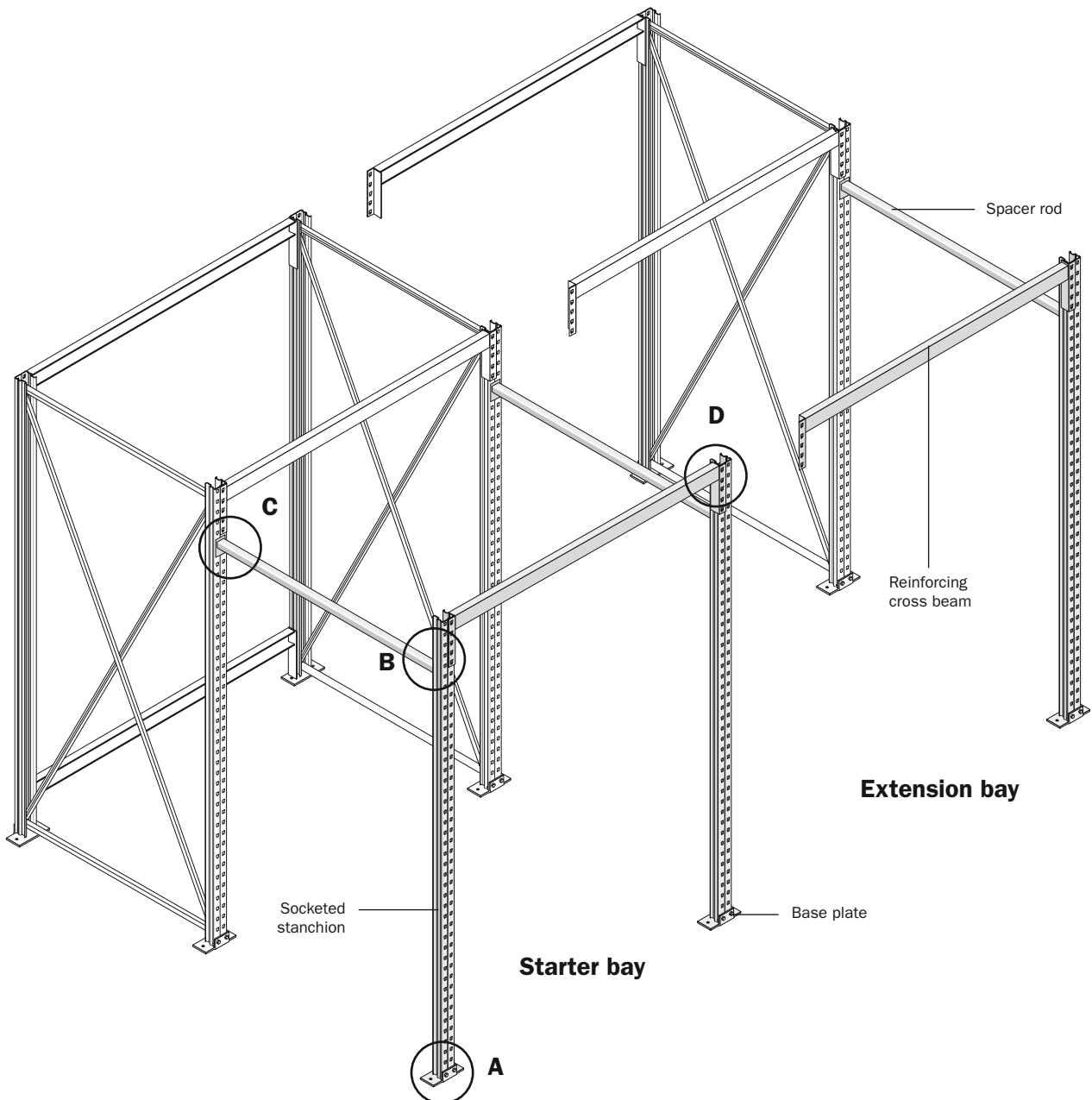

6.3.1 Dimensions and parts list

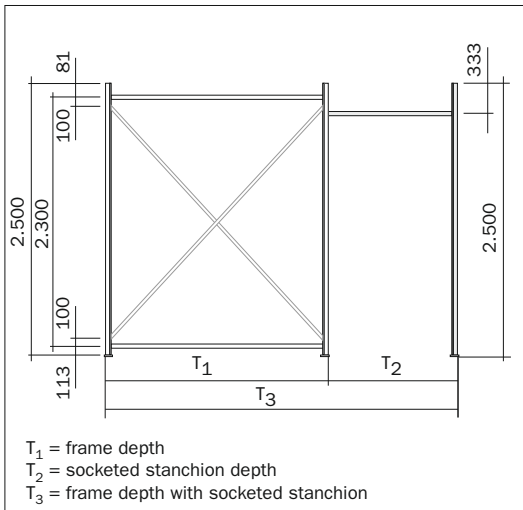

Assembly distances for the X framework (frame type 2)									
Profile	Frame height mm	Framework height mm	Frame depth T_1 mm			Socketed stanchion T_2 mm			
P73	2.500	2.100	1.050	1.650	2.050	400	600	1.000	1.600

Parts list for starter bay											
Socketed stanchion	Spacer rod	Reinforcing cross beam	Screw M10 x 65 mm, M10 x 75 mm	Screw M10 x 30 mm	Biloc nut M10	Washer 10,5	Screw M8 x 20 mm	Biloc nut M8	Washer 8,4	Distance sleeve	Base plate
2	2	1	2	6	8	8	2	2	2	1	2

Parts list for extension bay											
Socketed stanchion	Spacer rod	Reinforcing cross beam	Screw M10 x 65 mm, M10 x 75 mm	Screw M10 x 30 mm	Biloc nut M10	Washer 10,5	Screw M8 x 20 mm	Biloc Mutter M8	Washer 8,4	Distanzhülse	Base plate
1	1	1	1	3	4	4	2	2	2	1	2

6.3.2 Assembly of socketed stanchion with frames P 73, P 93, P 95, P 13 or P 15

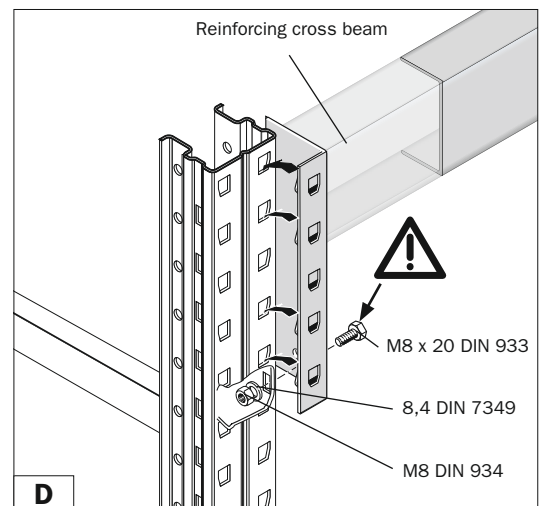
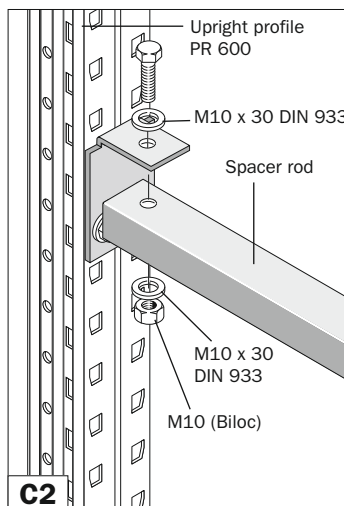
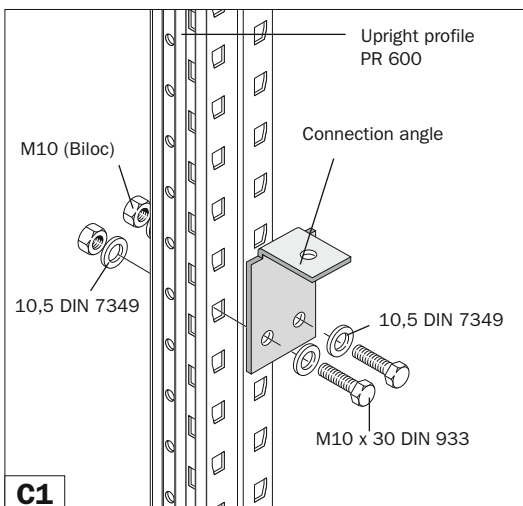
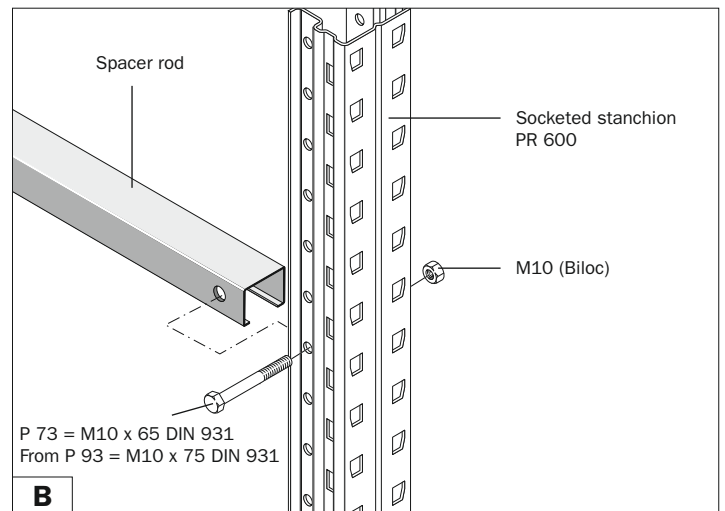
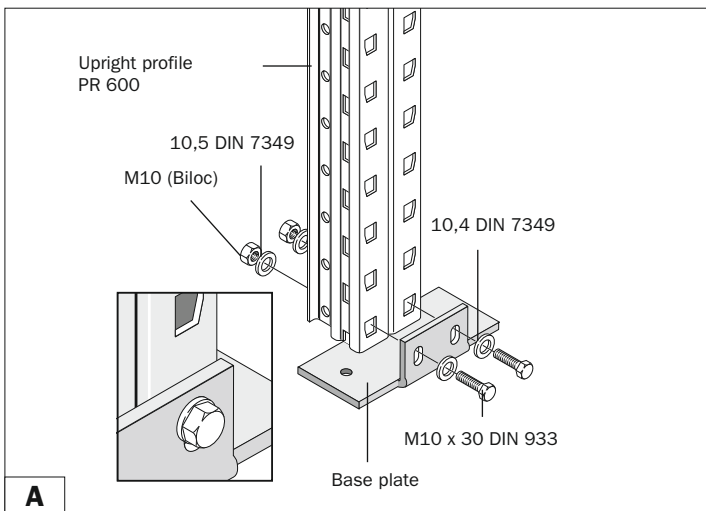

6.4 Assembly of PR 600 starter and extension bays for double-faced shelving with Z framework P 73, P 93, P 95, P 13, P 15

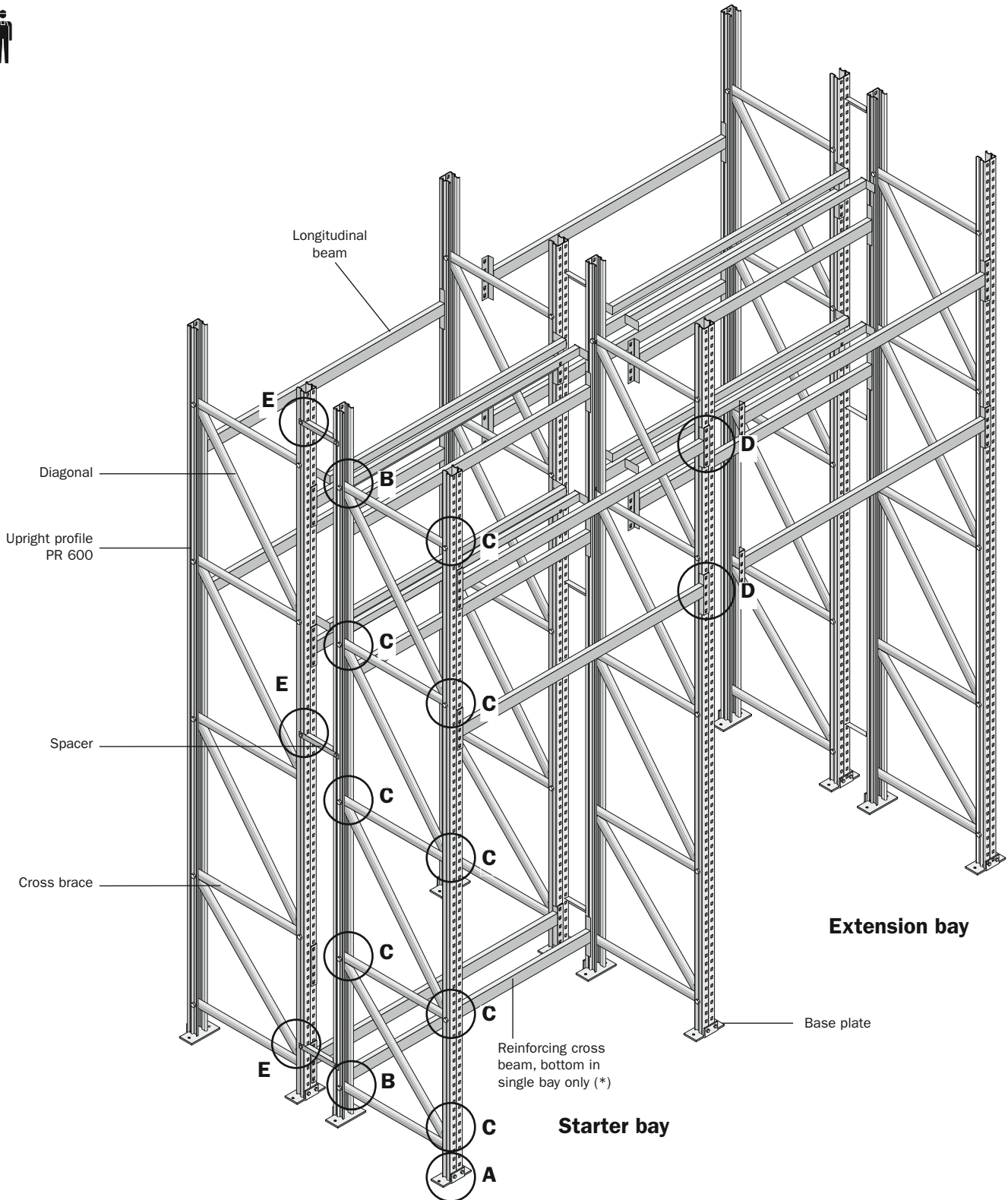

6.4.1 Dimensions and parts list

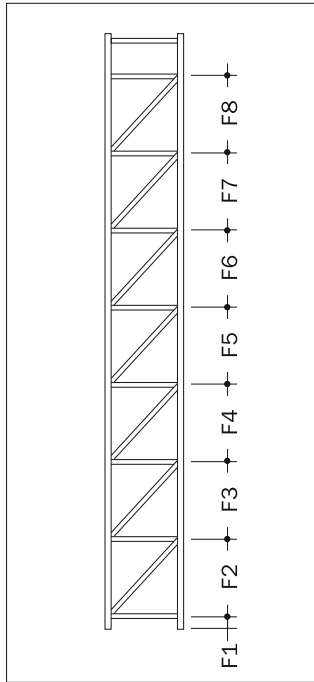

Assembly spacing of the PR 600 frameworks								
Frame height mm	Framework height (F) mm							
	F 1	F 2	F 3	F 4	F 5	F 6	F 7	F 8
2.200	163	800	1.100	-	-	-	-	-
2.500	163	1.100	1.100	-	-	-	-	-
2.700	163	800	1.100	500	-	-	-	-
3.000	163	1.100	1.100	500	-	-	-	-
3.300	163	1.100	1.400	500	-	-	-	-
3.600	163	1.100	1.100	1.100	-	-	-	-
3.800	163	800	1.100	1.100	500	-	-	-
4.100	163	1.100	1.100	1.100	500	-	-	-
4.400	163	1.100	1.100	1.400	500	-	-	-
4.700	163	1.100	1.100	1.100	1.100	-	-	-
4.900	163	800	1.100	1.100	1.100	500	-	-
5.200	163	1.100	1.100	1.100	1.100	500	-	-
5.500	163	1.100	1.100	1.100	1.400	500	-	-
5.800	163	800	1.100	1.100	1.100	1.400	-	-
6.000	163	800	800	1.100	1.100	1.400	500	-
6.300	163	800	1.100	1.100	1.100	1.400	500	-
6.600	163	800	1.100	1.100	1.400	1.400	500	-
6.900	163	800	1.100	1.100	1.100	1.100	1.400	-
7.100	163	800	800	1.100	1.100	1.100	1.400	500
7.400	163	800	1.100	1.100	1.100	1.100	1.400	500

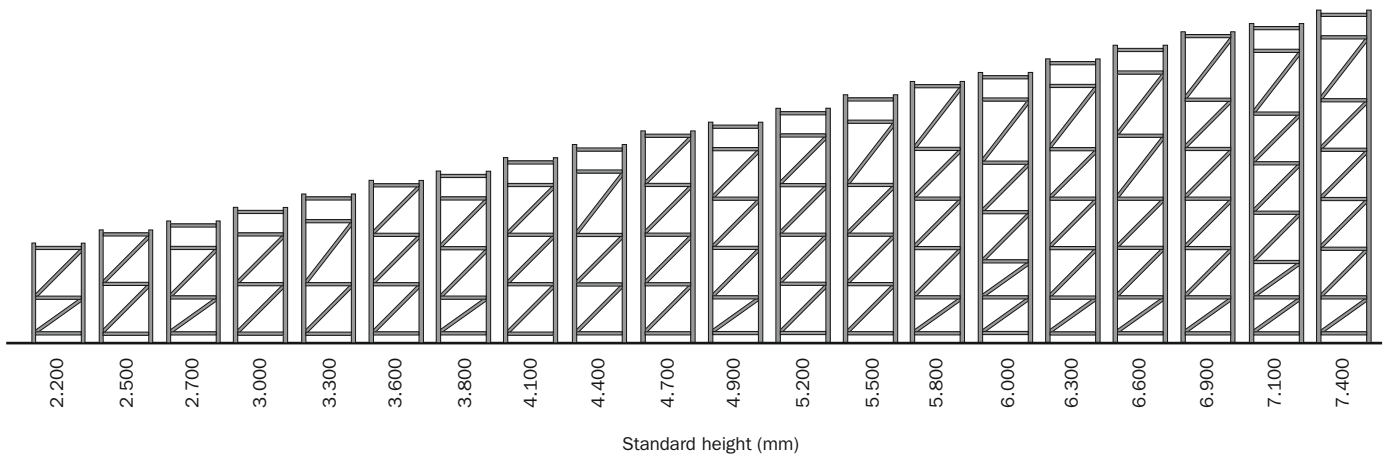

Parts list for PR 600	
Base frame:	consisting of 2 uprights and 2 standard feet
Frame depth:	850 mm, 1050 mm and 1250 mm
Upright width:	75 mm, 90 mm, 100 mm, 140 mm
Material thickness of the frame depending on load:	1,75 mm; 2,00 mm; 2,50 mm; 2,75 mm; 3,00 mm

Parts list for starter bay														
Frame height mm	Diagonals for framework height			Cross brace	Screw M10 x 75 mm	Screw M10 x 30 mm	Biloc nut M10	Washer 10,5	Screw M8 x 25 mm	Biloc nut M8	Washer 8,4	Distance sleeve	Base plate	Spacer
	800 mm	1.100 mm	1.400 mm											
2.200	2	2	-	6	12	8	20	16	8	8	16	4	4	4
2.500	-	4	-	6	12	8	20	16	8	8	16	4	4	4
2.700	2	2	-	8	16	8	24	16	8	8	16	8	4	4
3.000	-	4	-	8	16	8	24	16	12	12	24	8	4	6
3.300	-	2	2	8	16	8	24	16	12	12	24	8	4	6
3.600	-	6	-	8	16	8	24	16	12	12	24	4	4	6
3.800	2	4	2	10	20	8	28	16	12	12	24	8	4	6
4.100	-	6	-	10	20	8	28	16	12	12	24	8	4	6
4.400	-	4	2	10	20	8	28	16	12	12	24	8	4	6
4.700	-	8	-	10	20	8	28	16	12	12	24	4	4	6
4.900	2	6	-	12	24	8	32	16	16	16	32	8	4	8
5.200	-	8	-	12	24	8	32	16	16	16	32	8	4	8
5.500	-	6	2	12	24	8	32	16	16	16	32	8	4	8
5.800	2	6	2	12	24	8	32	16	16	16	32	4	4	8
6.000	4	4	2	14	28	8	36	16	16	16	32	8	4	8
6.300	2	6	2	14	28	8	36	16	20	20	40	8	4	10
6.600	2	4	4	14	28	8	36	16	20	20	40	8	4	10
6.900	2	8	2	14	28	8	36	16	20	20	40	4	4	10
7.100	4	6	2	16	32	8	40	16	20	20	40	8	4	10
7.400	2	8	2	16	32	8	40	16	20	20	40	8	4	10

Parts list for extension bay														
Frame height mm	Diagonals for framework height			Cross brace	Screw M10 x 75 mm	Screw M10 x 30 mm	Biloc nut M10	Washer 10,5	Screw M8 x 25 mm	Biloc nut M8	Washer 8,4	Distance sleeve	Base plate	Spacer
	800 mm	1.100 mm	1.400 mm											
2.200	1	1	-	3	6	4	10	8	4	4	8	2	2	2
2.500	-	2	-	3	6	4	10	8	4	4	8	2	2	2
2.700	1	1	-	4	8	4	12	8	4	4	8	4	2	2
3.000	-	2	-	4	8	4	12	8	6	6	12	4	2	3
3.300	-	1	1	4	8	4	12	8	6	6	12	4	2	3
3.600	-	3	-	4	8	4	12	8	6	6	12	2	2	3
3.800	1	2	1	5	10	4	14	8	6	6	12	4	2	3
4.100	-	3	-	5	10	4	14	8	6	6	12	4	2	3
4.400	-	2	1	5	10	4	14	8	6	6	12	4	2	3
4.700	-	4	-	5	10	4	14	8	6	6	12	2	2	3
4.900	1	3	-	6	12	4	16	8	8	8	16	4	2	4
5.200	-	4	-	6	12	4	16	8	8	8	16	4	2	4
5.500	-	3	1	6	12	4	16	8	8	8	16	4	2	4
5.800	1	3	1	6	12	4	16	8	8	8	16	2	2	4
6.000	2	2	1	7	14	4	18	8	8	8	16	4	2	4
6.300	1	3	1	7	14	4	18	8	10	10	20	4	2	5
6.600	1	2	2	7	14	4	18	8	10	10	20	4	2	5
6.900	1	4	1	7	14	4	18	8	10	10	20	2	2	5
7.100	2	3	1	8	16	4	20	8	10	10	20	4	2	5
7.400	1	4	1	8	16	4	20	8	10	10	20	4	2	5

6.4.2 Assembly of frames P 73, P 93, P 95, P 13 or P 15 with Z framework

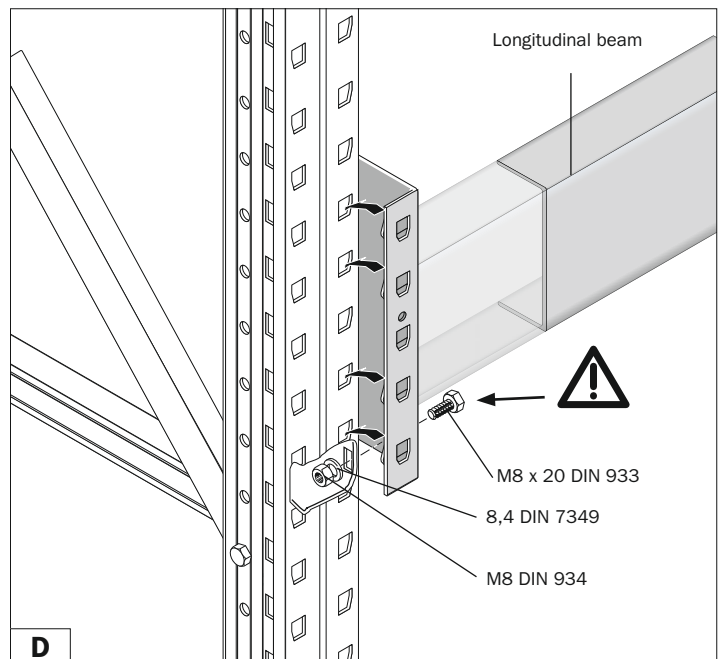
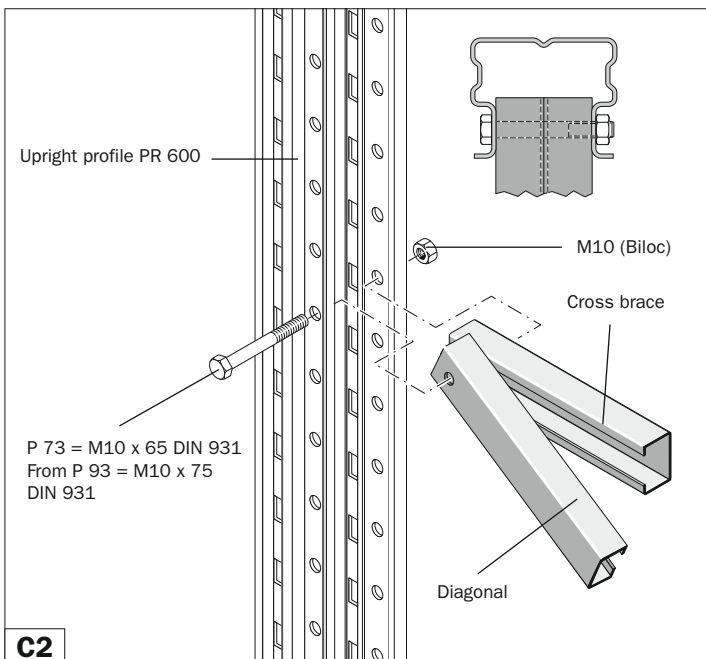
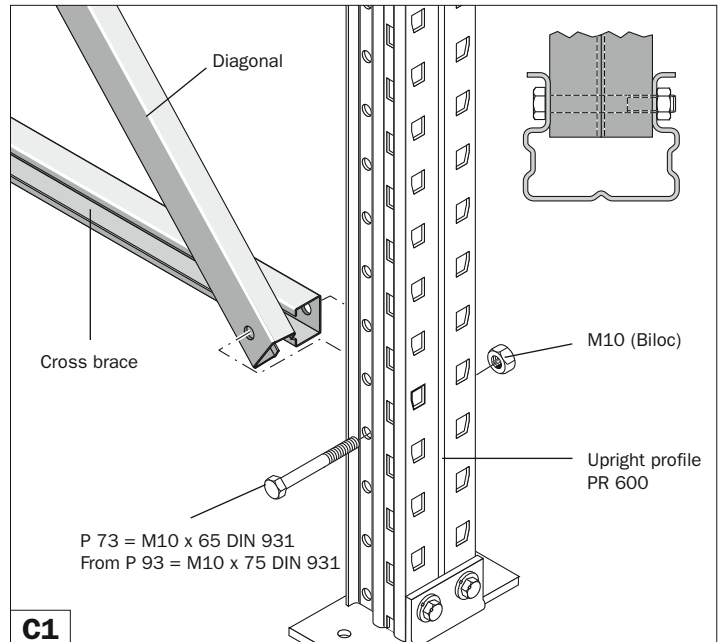
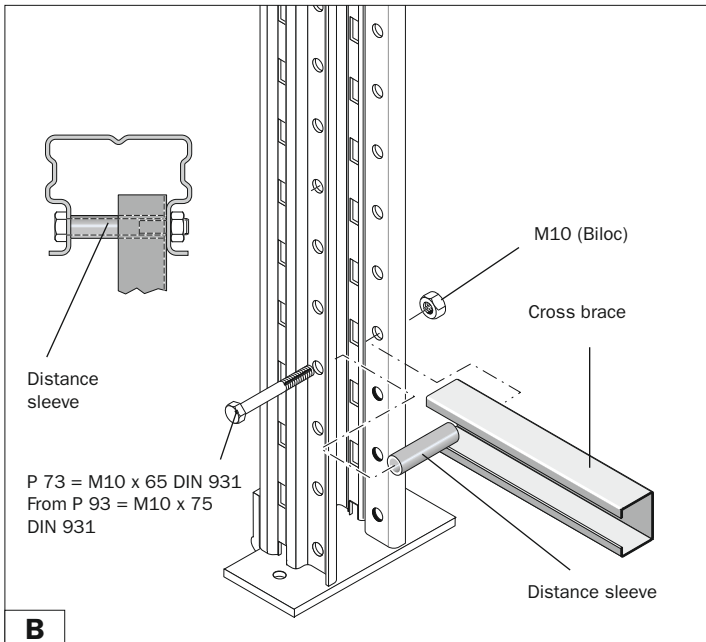
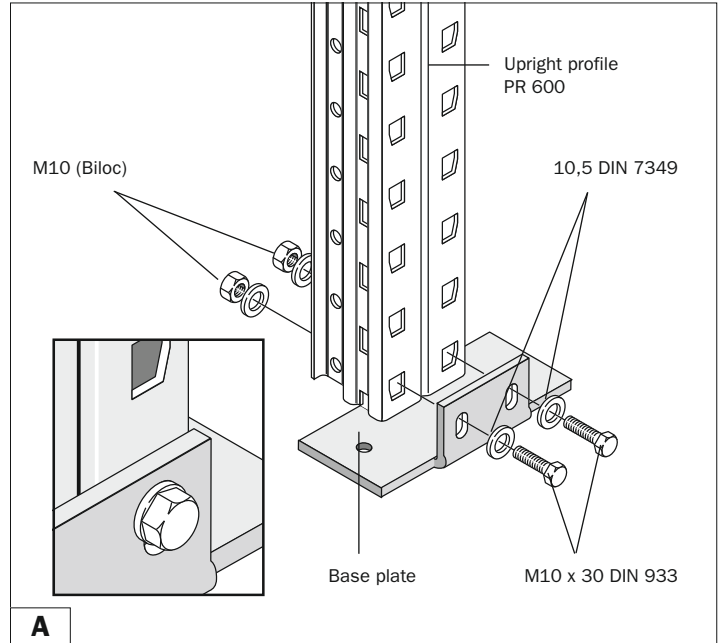
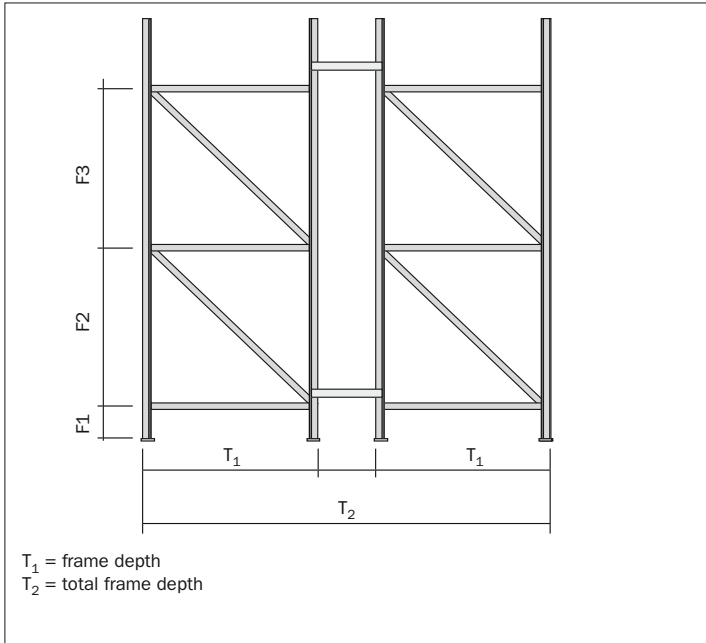

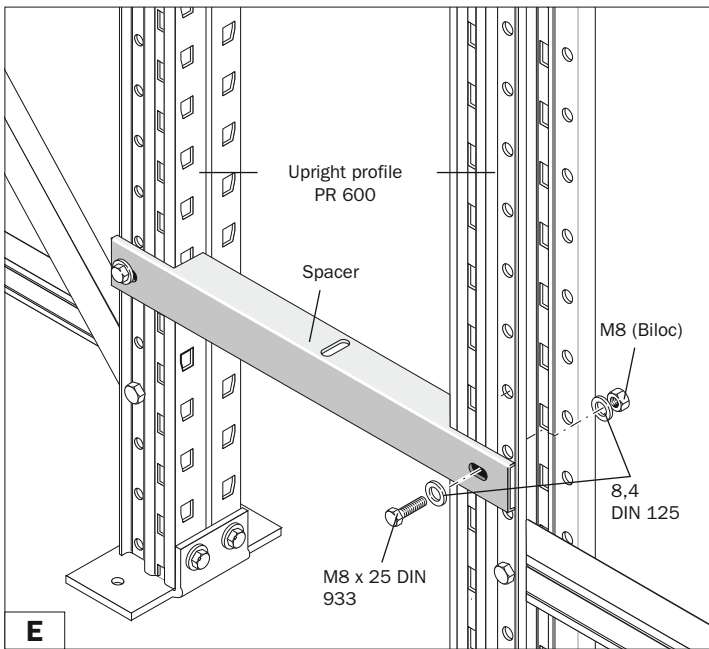

6.5 Assembly of the socketed stanchion for frames P 73, P 93, P 95, P 13 or P 15 with Z framework

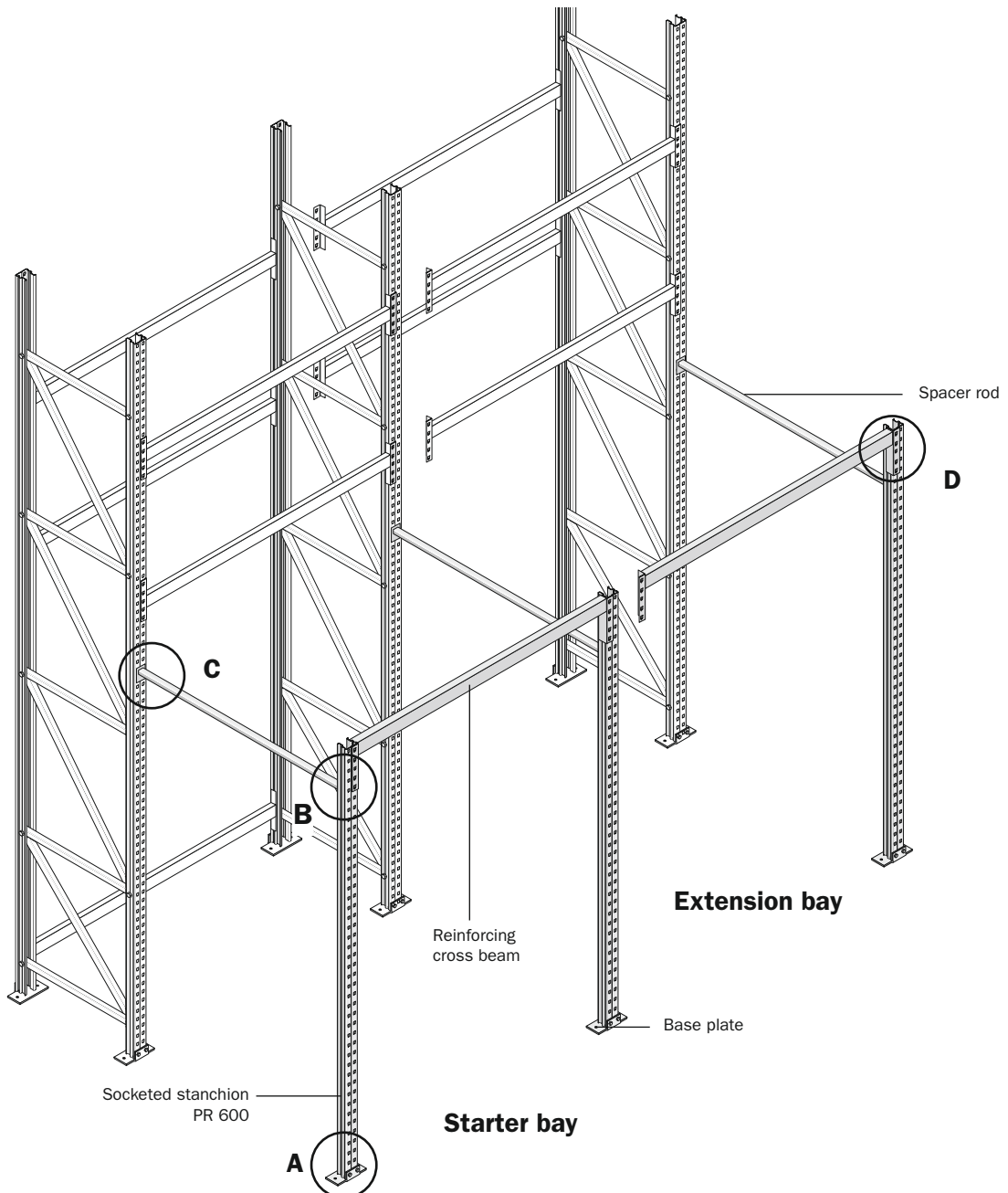

6.5.1 Dimensions and parts list

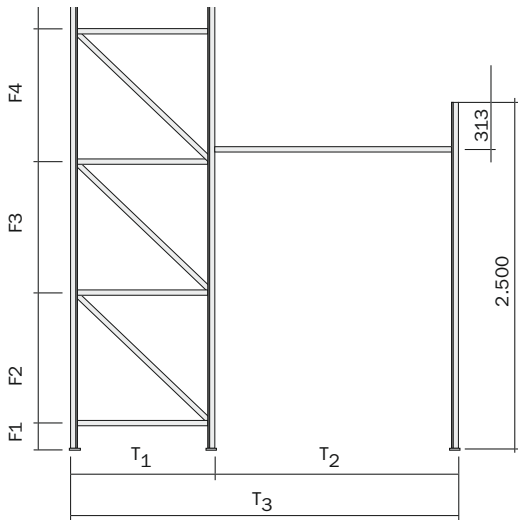

Assembly distances for the X framework (frame type 2)

Profile	Frame depth T_1 mm	Socketed stanchion depth T_2 mm			
		400	600	1.000	1.600
P73, P93, P95, P13, P15	1.050				

T_1 = frame depth
 T_2 = socketed stanchion depth
 T_3 = frame depth with socketed stanchion

Parts list for starter bay

Socketed stanchion	Spacer rod	Reinforcing cross beam	Screw M10 x 65 mm, M10 x 75 mm	Screw M10 x 30 mm	Biloc nut M10	Washer 10,5	Screw M8 x 20 mm	Biloc nut M8	Washer 8,4	distance sleeve	Base plate
2	2	1	2	10	12	12	2	2	2	-	2

Parts list for extension bay

Socketed stanchion	Spacer rod	Reinforcing cross beam	Screw M10 x 65 mm, M10 x 75 mm	Screw M10 x 30 mm	Biloc nut M10	Washer 10,5	Screw M8 x 20 mm	Biloc nut M8	Washer 8,4	distance sleeve	Base plate
1	1	1	1	5	6	6	2	2	2	-	1

6.5.2 Assembly of socketed stanchion with frames P 73, P 93, P 95, P 13 or P 15

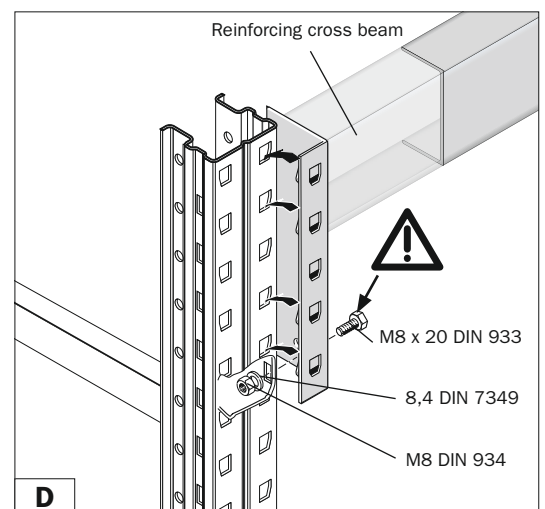
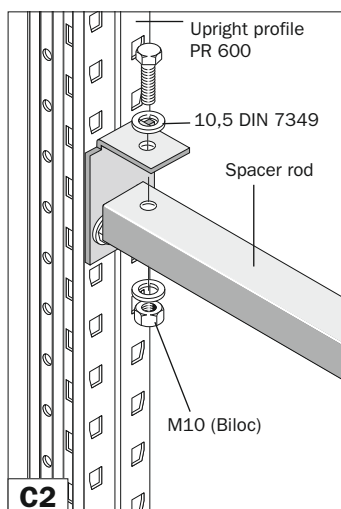
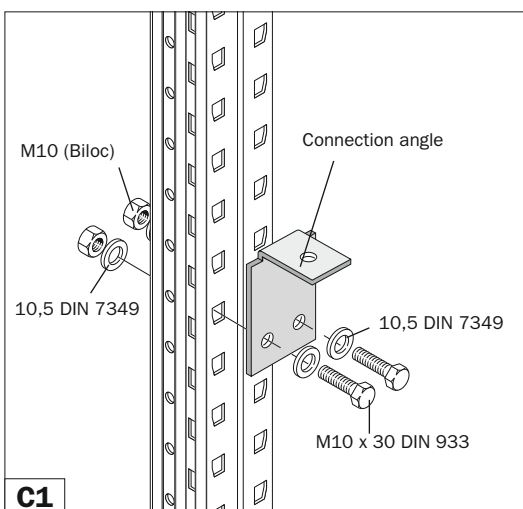
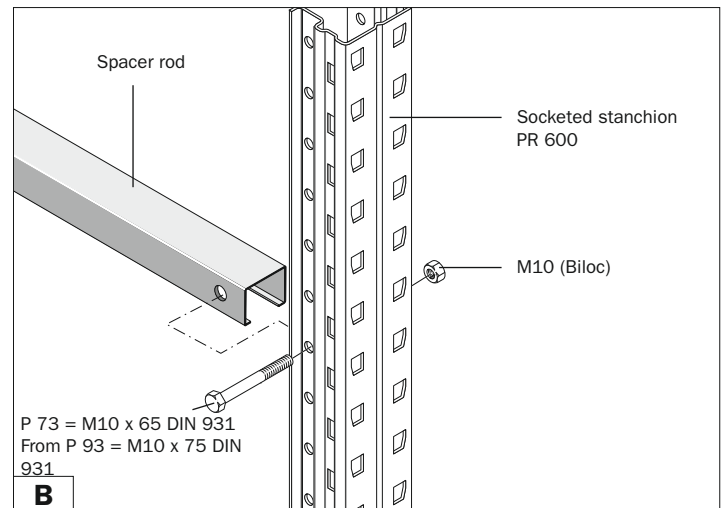
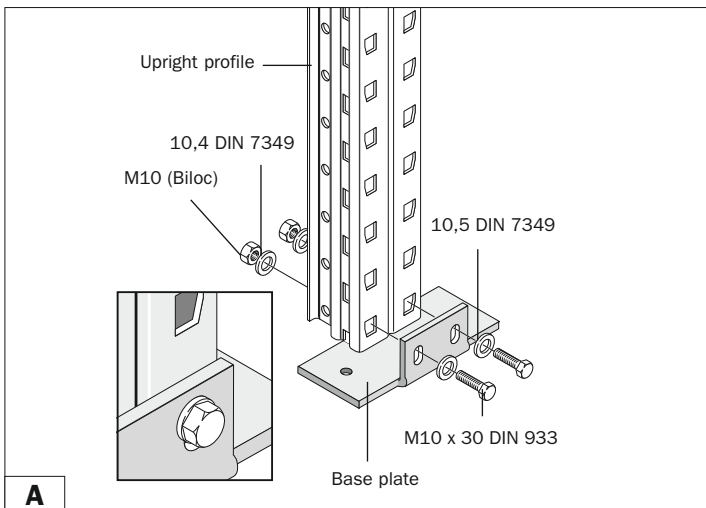

6.6 Floor anchoring

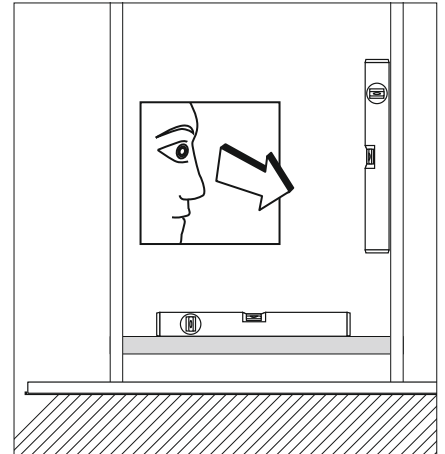
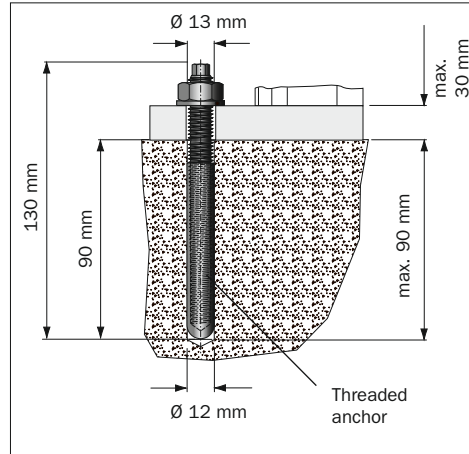
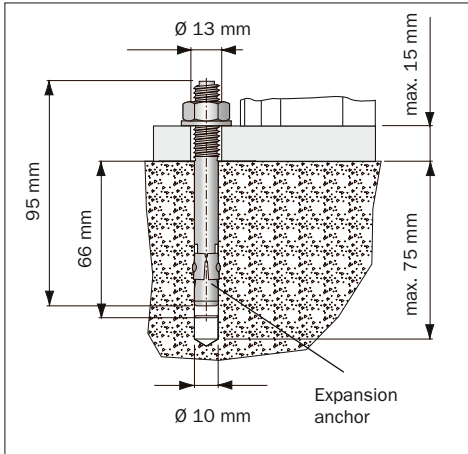

7.0 Assembly of flow bed frame

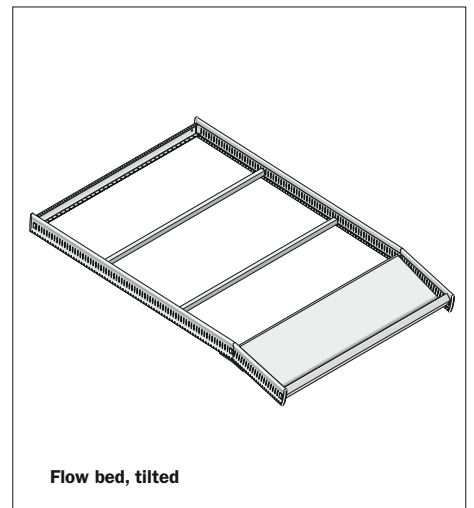
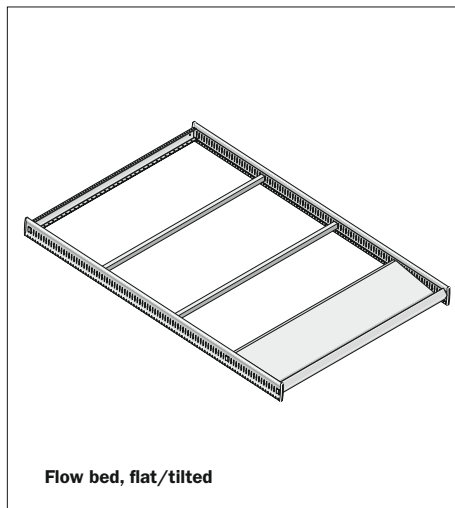
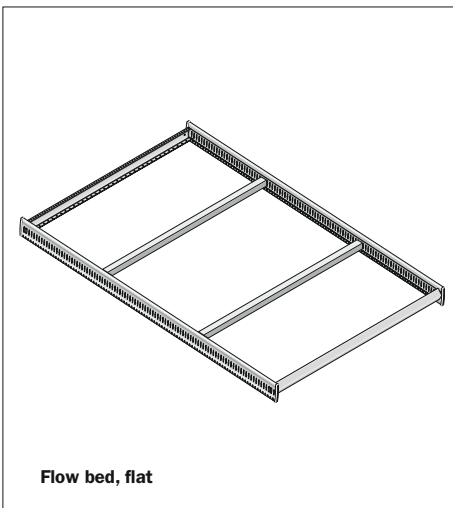
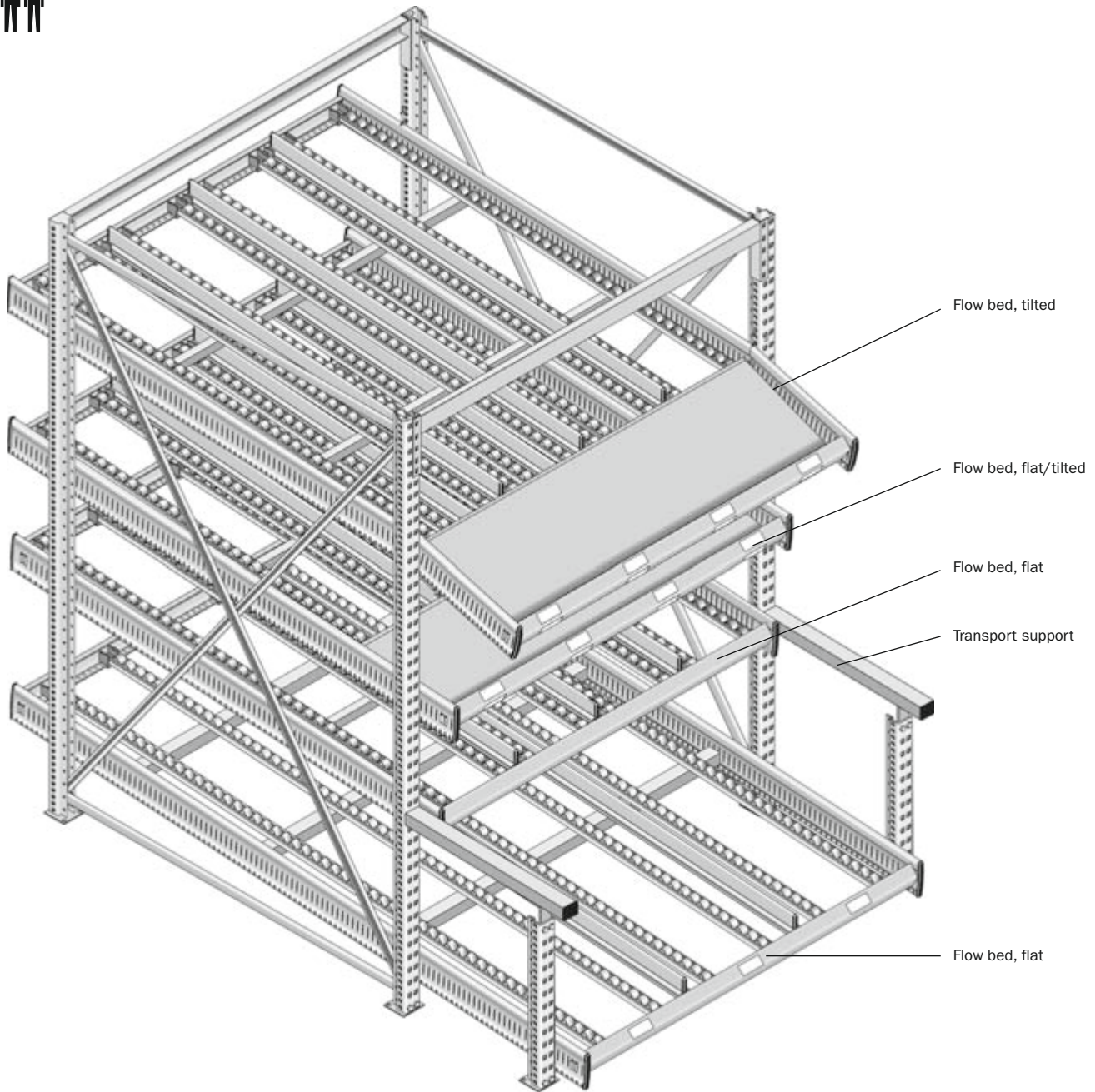

7.1 System components for live storage racking KDR – Flow bed frame modules

Rear cross connector

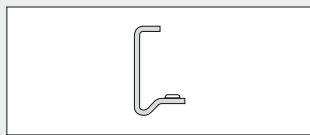
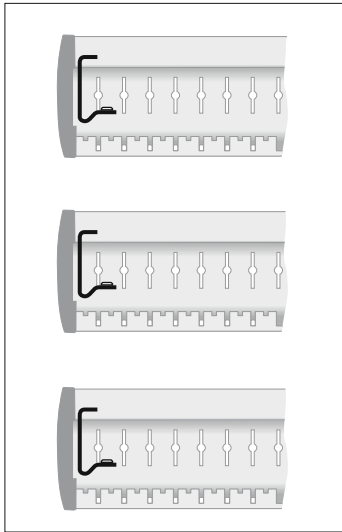

Rear cross connector K-QH
With higher trim to prevent movement.

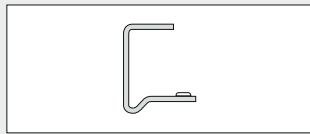

K-QH-KLT back cross connector
Wide upper trim. This prevents open KLT containers on the floor from becoming hooked up.

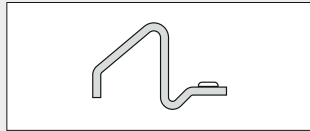

K-QK tilted cross connector
Used for automatic replenishment e.g. shelf-servicing devices, without locking device.

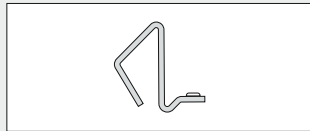

K-QV front cross connector
If used for push-in racking, this profile can be fitted with a raised trim at the back.

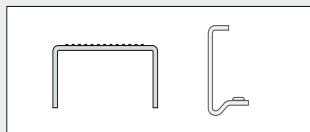

K-QT step cross connector
Integrated step on the replenishment side. This is achieved by extending the side profile accordingly. To secure in place, the side profile must be bolted to the support.

Central/internal cross connector

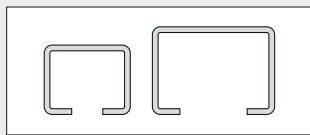
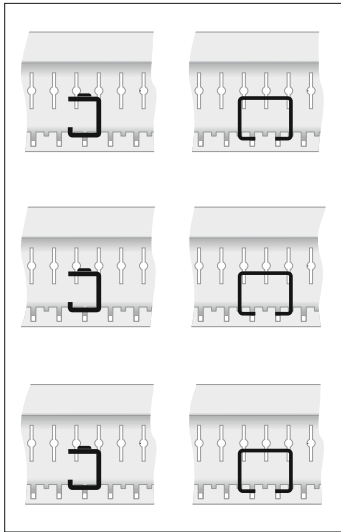

K-QI internal cross connector
Support for roller tracks. The load capacity of the flow bed is determined by the number of cross connectors. Can also be used to support the outlet tray with high loads and significant depths.

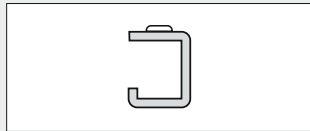

K-QM central cross connector
On flow beds longer than 3100 mm this profile can be used in conjunction with the docking clip to increase the stabilisation of the roller tracks and sashes.

Cross connector, tilted

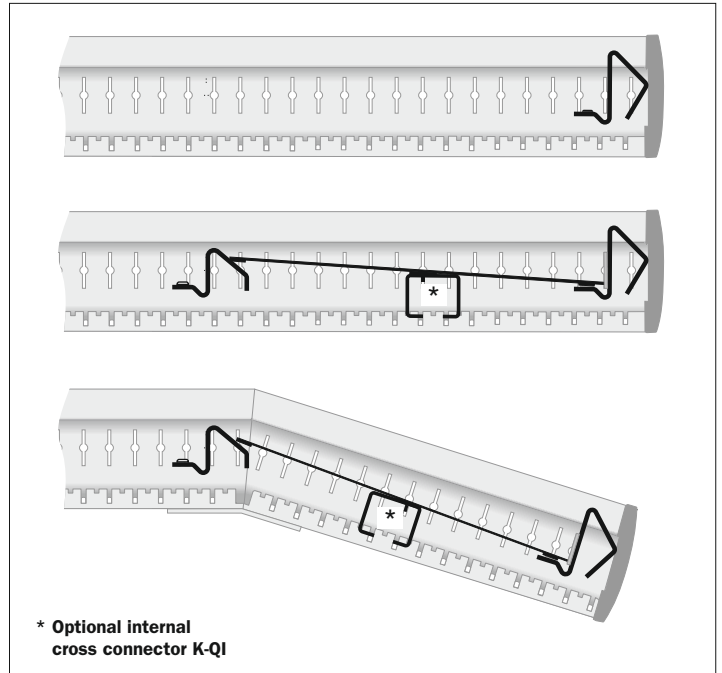

* Optional internal cross connector K-QI

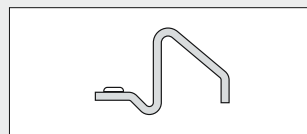

K-QK tilted cross connector
Used for tilted discharges. For fixing roller tracks, sashes and outlet trays.

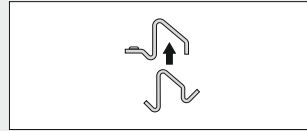

K-QKV tilted reinforcer
On large frame widths and heavy loads the profile can be used for reinforcement.

Front cross connector

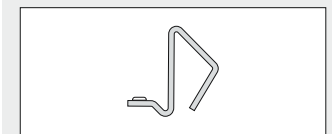
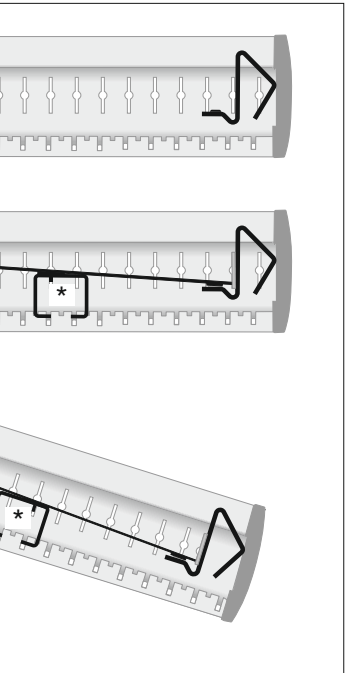

K-QV front cross connector
With raised trim.

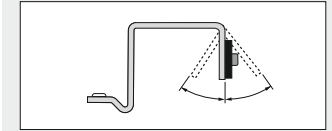

Front cross connector, pick-by-light K-QV-PBL
For fixing a pick-by-light display. The profile can be supplied in different individual angle positions.

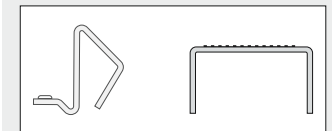

K-QT step cross connector
Integrated step on the picking side. This is achieved by extending the side profile accordingly. To secure in place, the side profile must be bolted to the support.

7.2 Pre-assembly of the side profiles

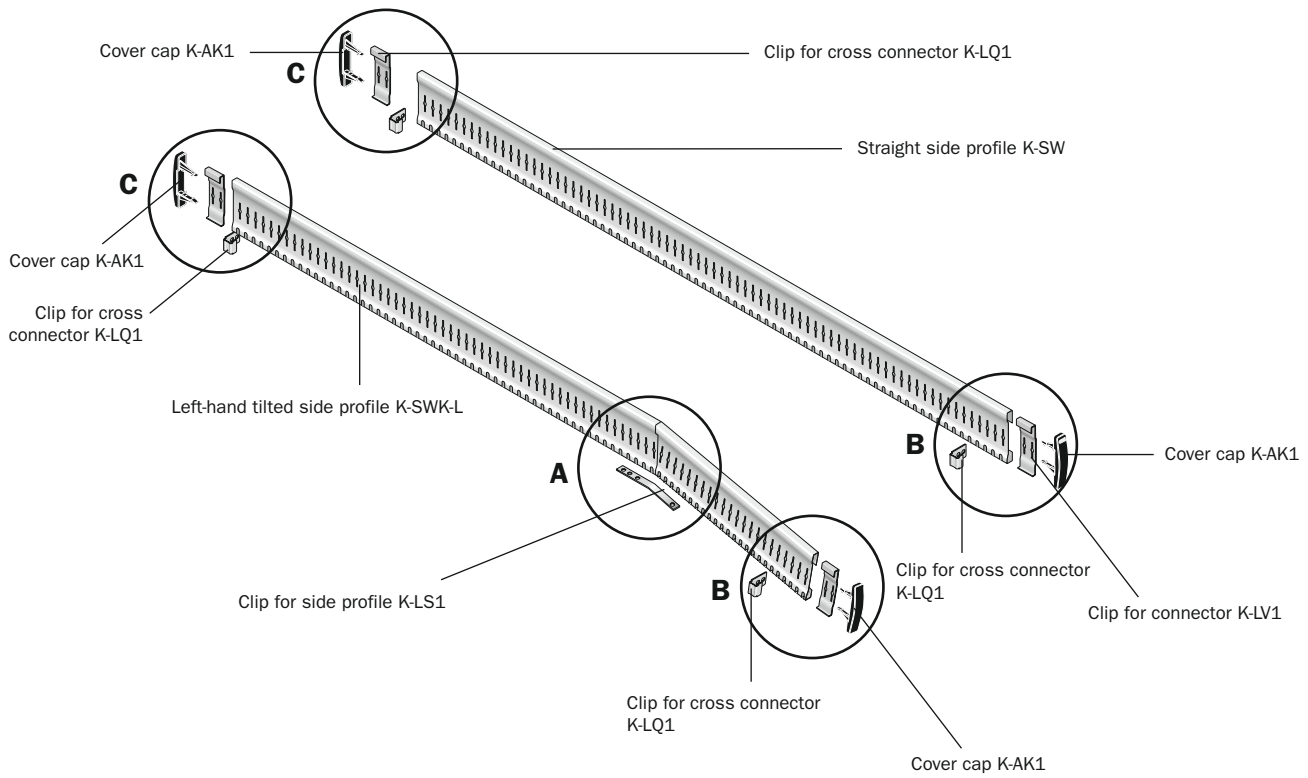

7.2.1 Bending of the side walls

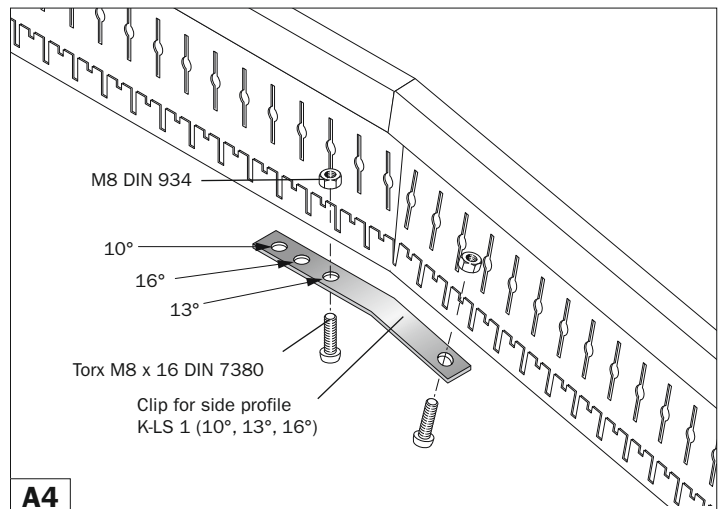
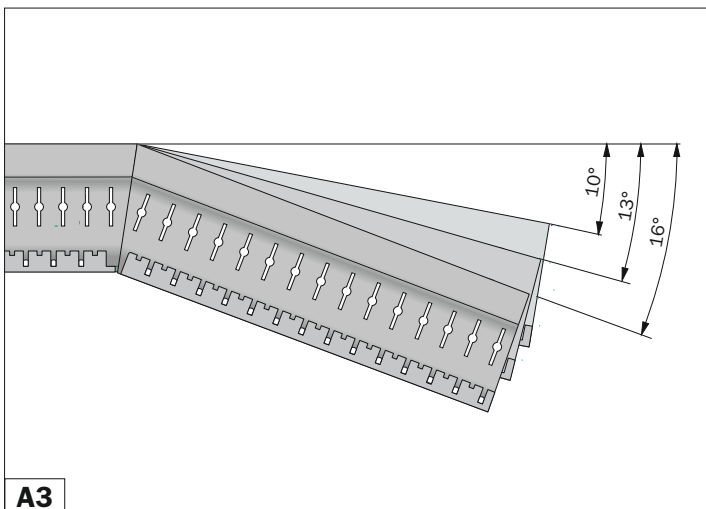
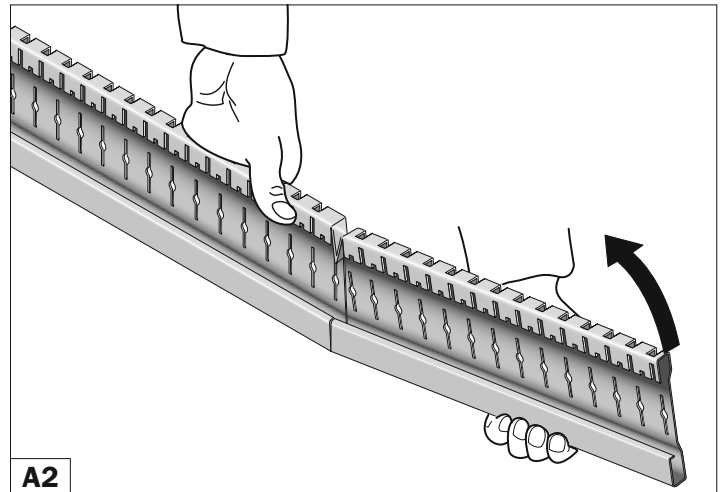
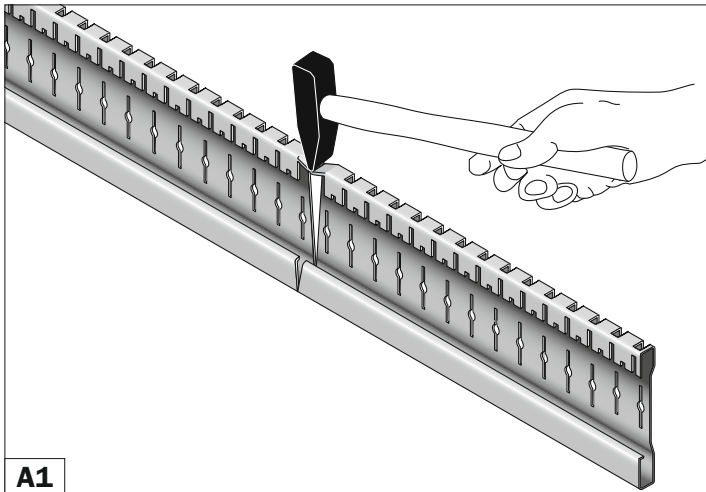

7.2.2 Pre-assembly of the front side profiles

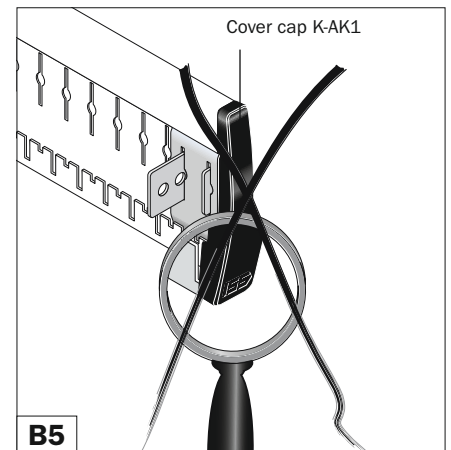
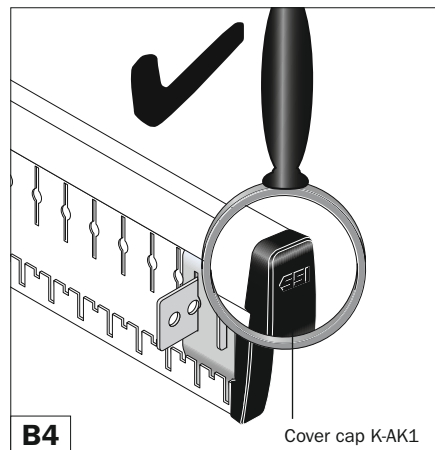
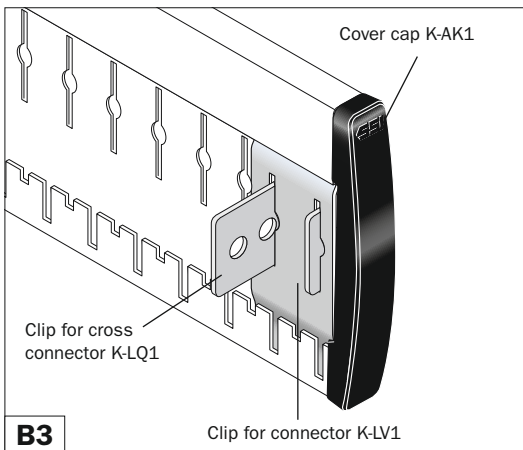
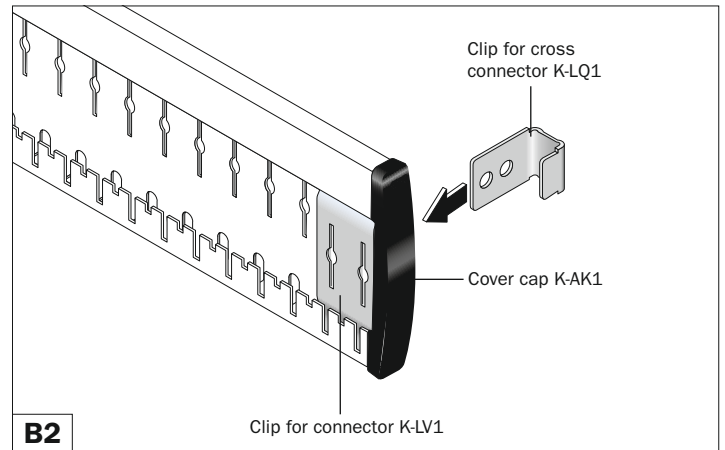
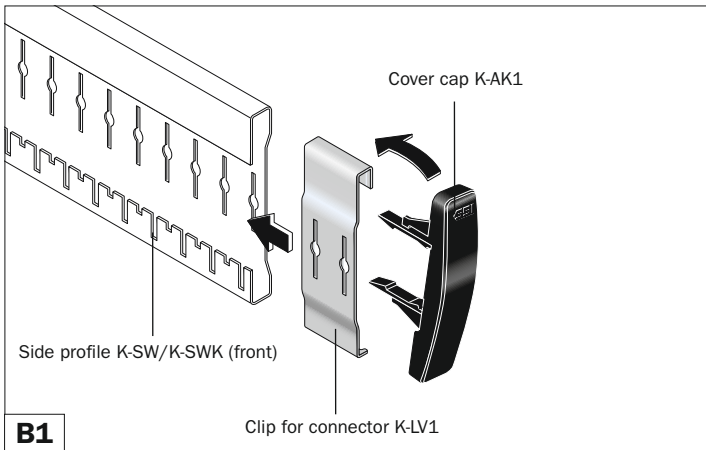

7.2.3 Pre-assembly of the rear side profiles

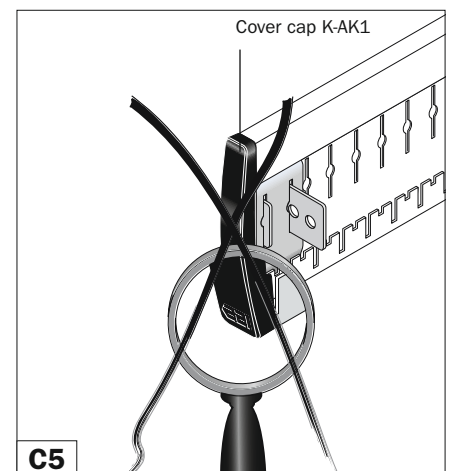
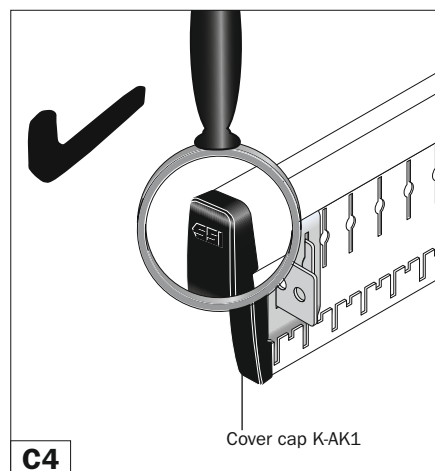
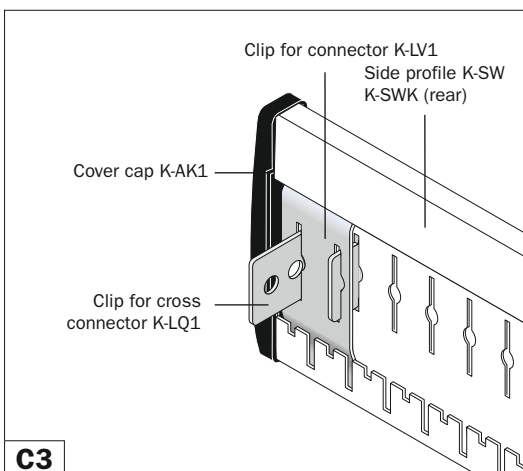
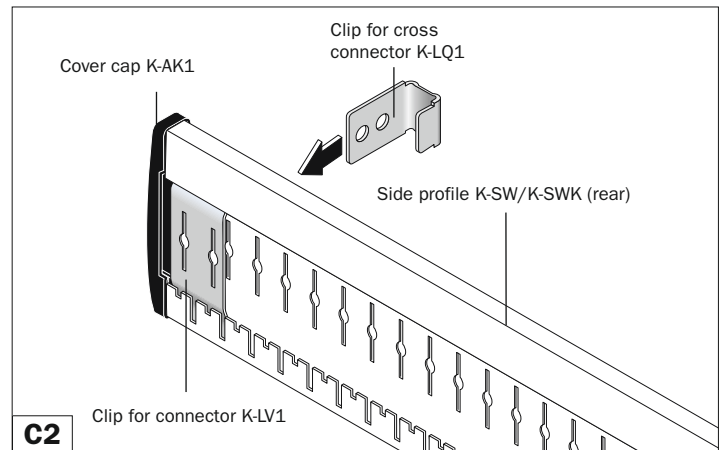
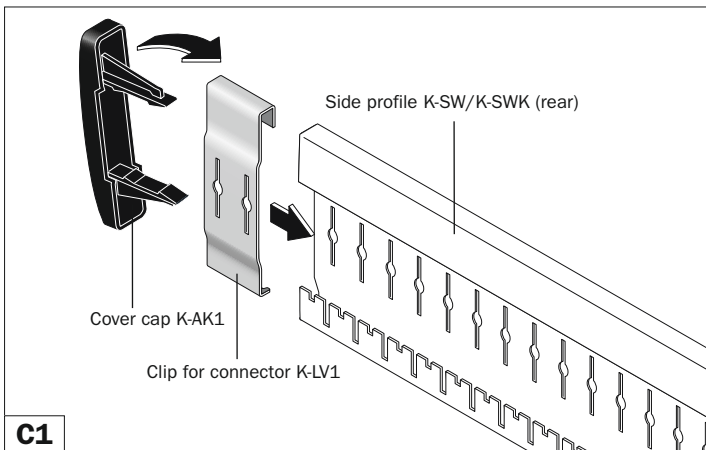

Ergonomics and adjustment options for the flow bed frame

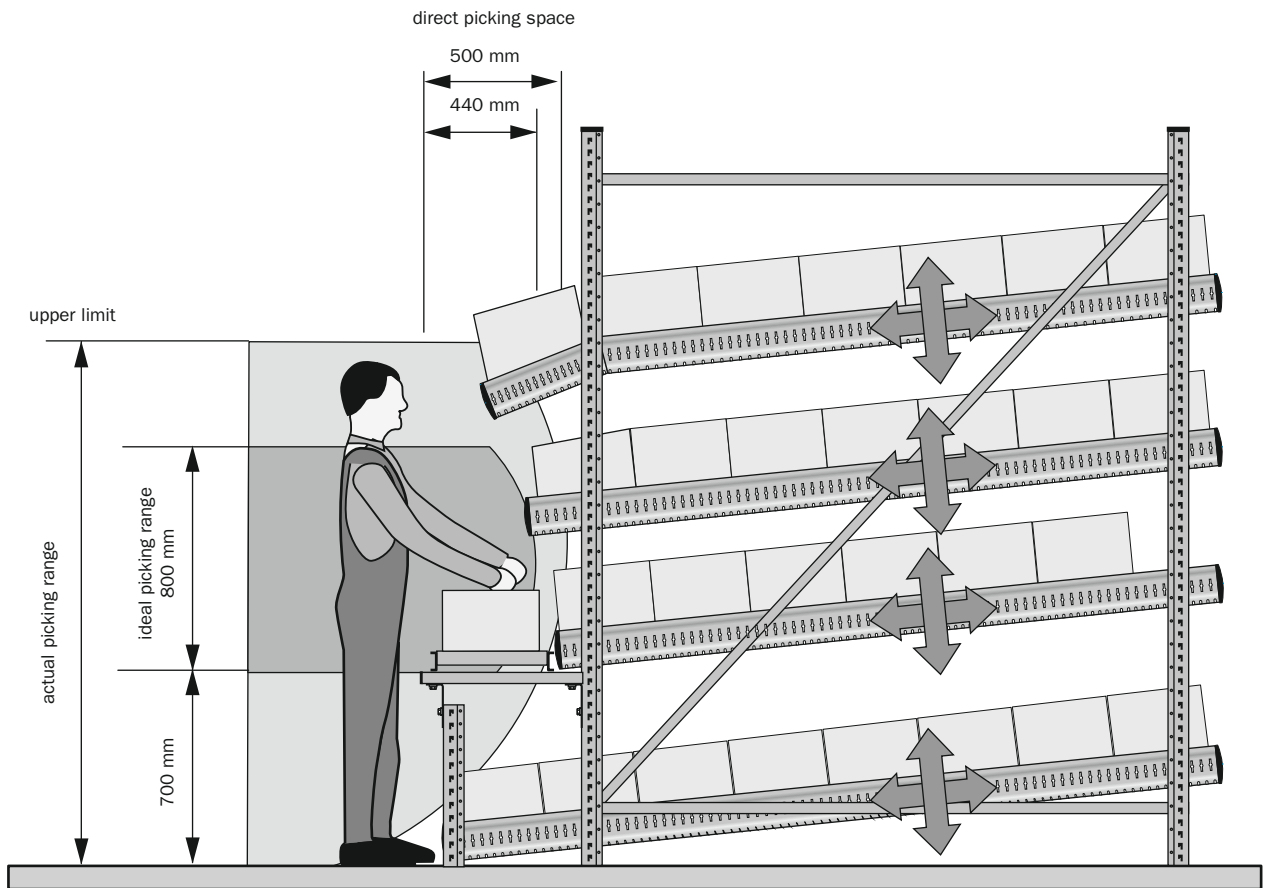

7.3.1 Height adjustment options for upright profiles P 63 and P 65

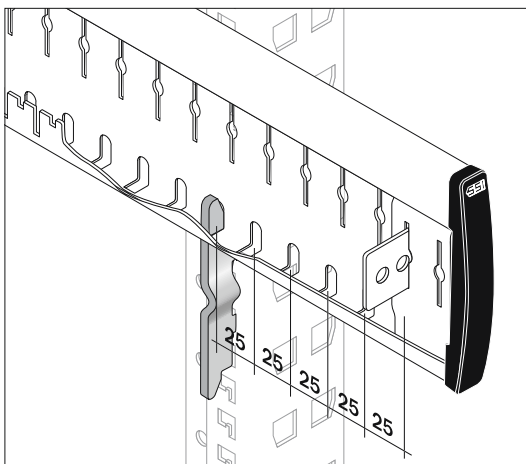
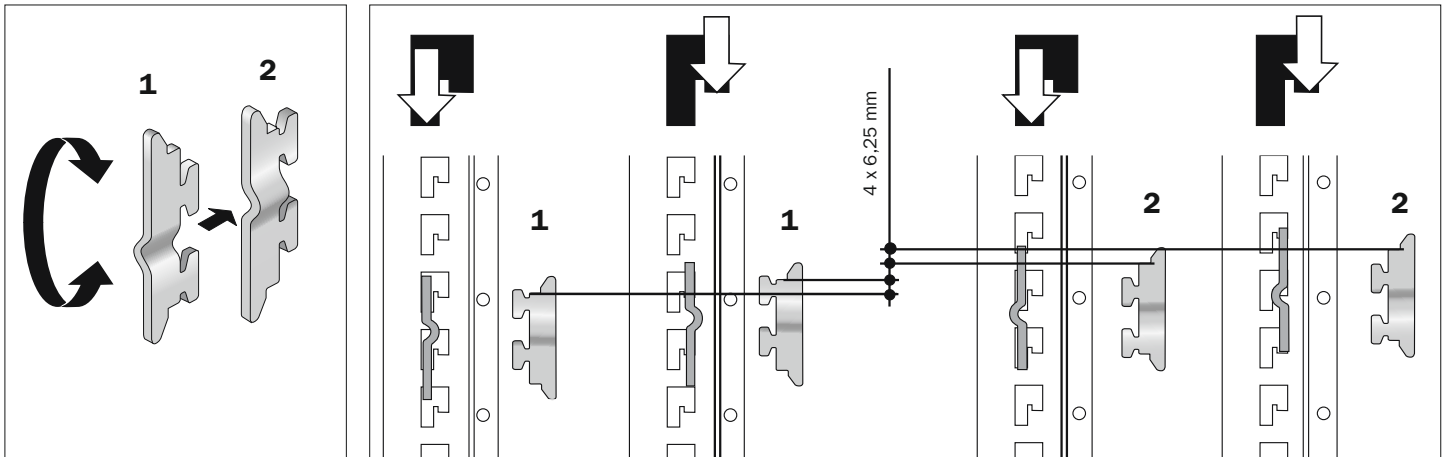

7.3.2 Height adjustment options for upright profiles P 73, P 93, P 95, P 13 and P 15

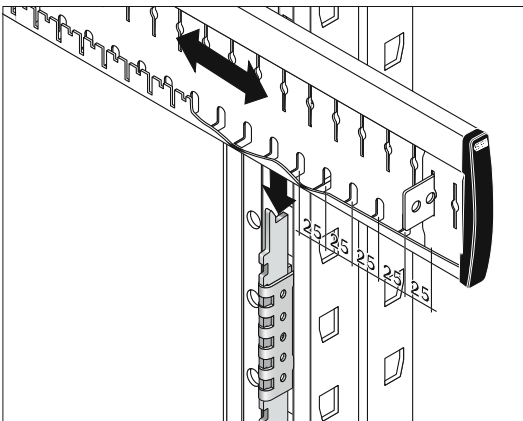
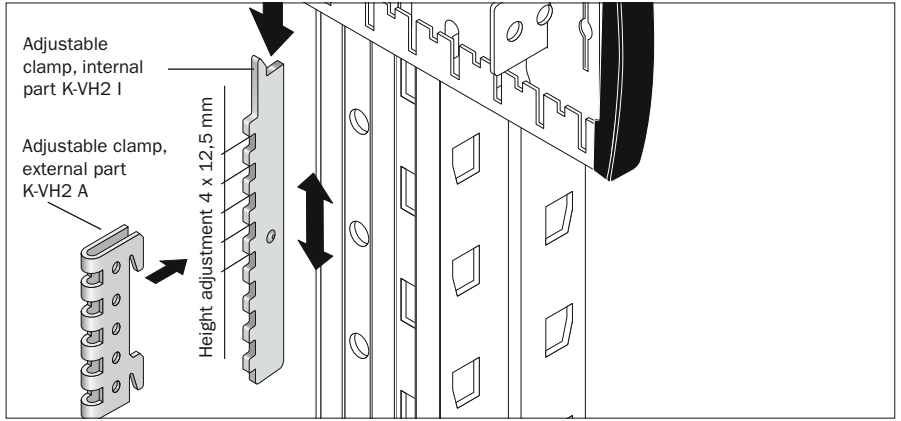
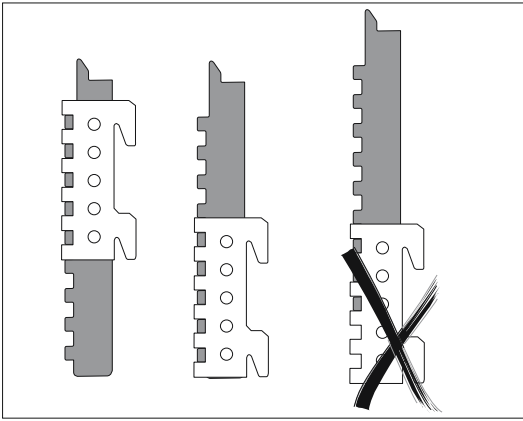

The adjustable clamp (external part) must be toothed complete with the adjustable clamp (internal part) and must not project outwards.

7.4 Attaching the side profiles

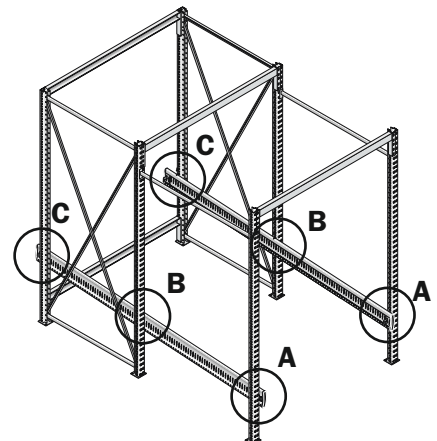
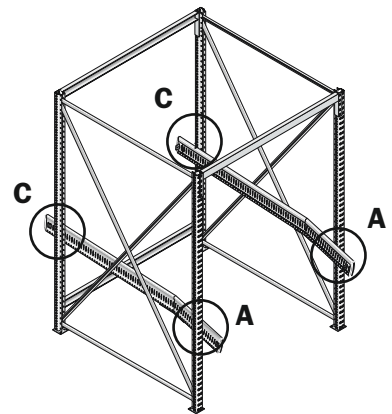
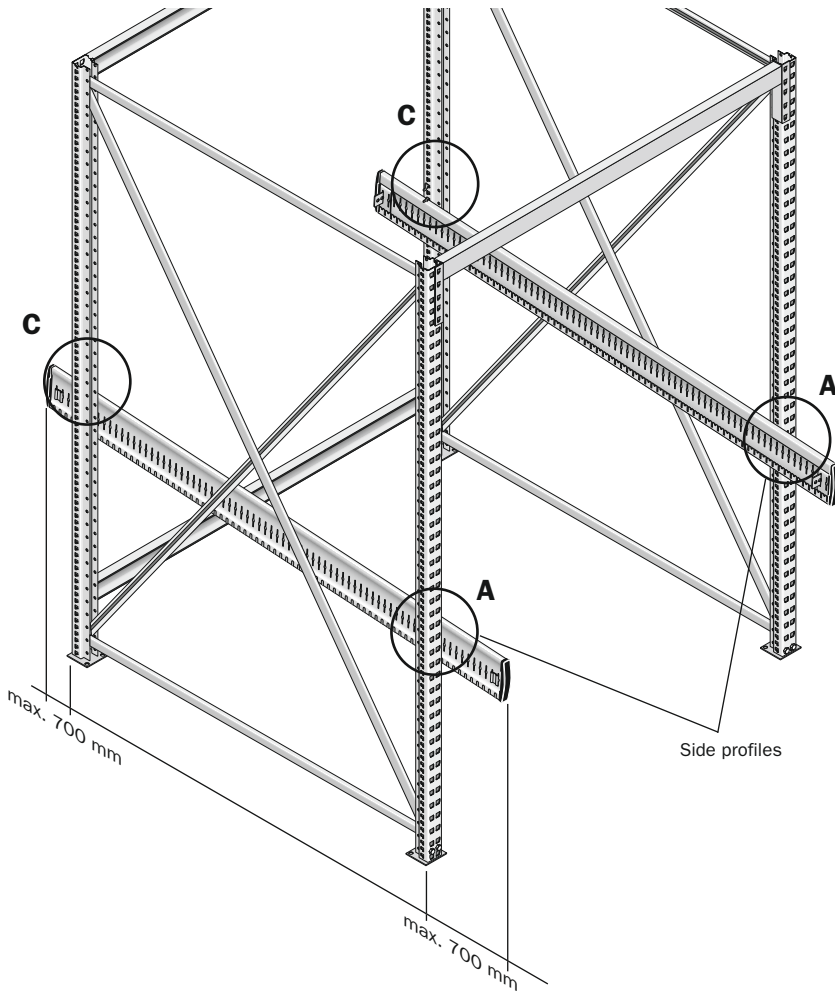

7.4.1 Attaching the front side profiles for upright profiles P 63 and P 65

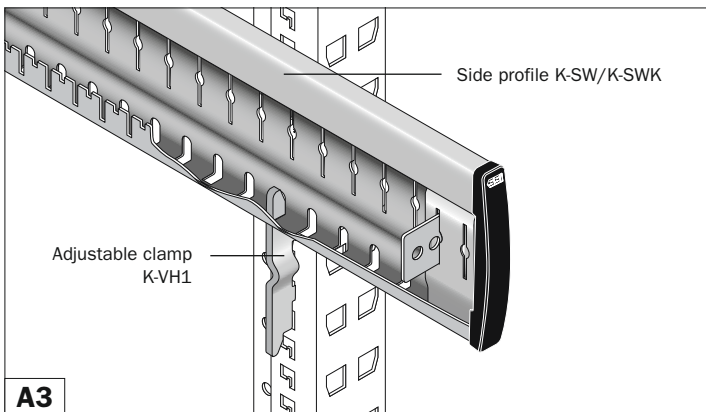
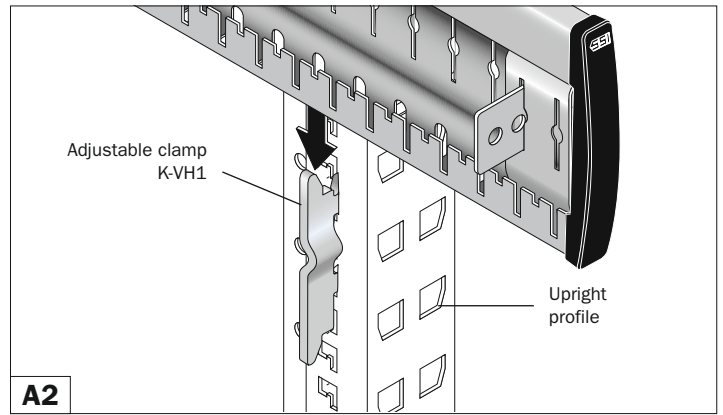
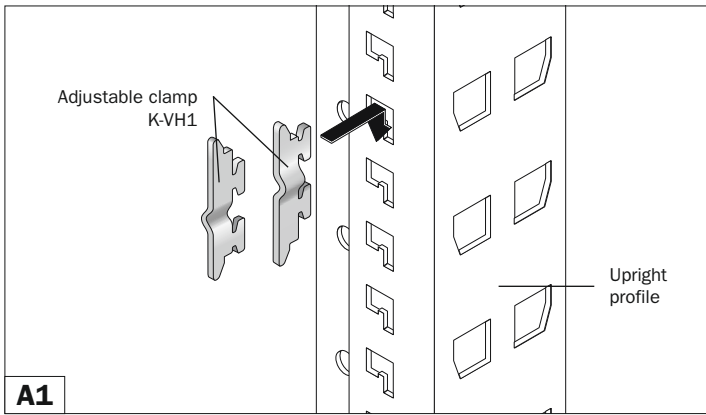

7.4.2 Attaching the internal side profiles for upright profiles P 63 and P 65

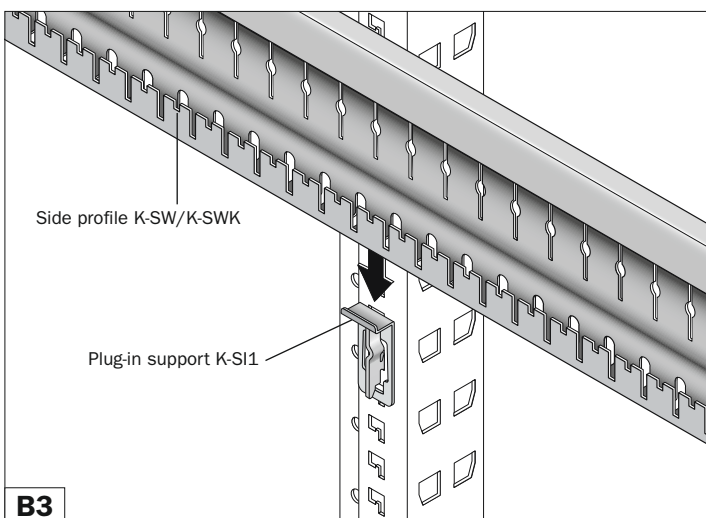
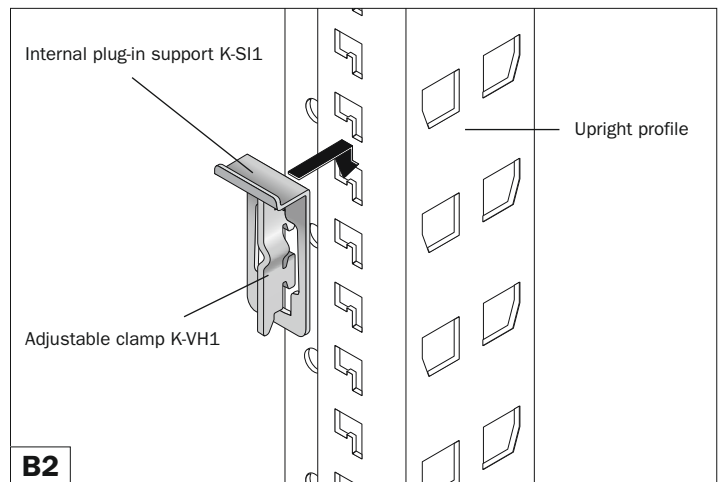
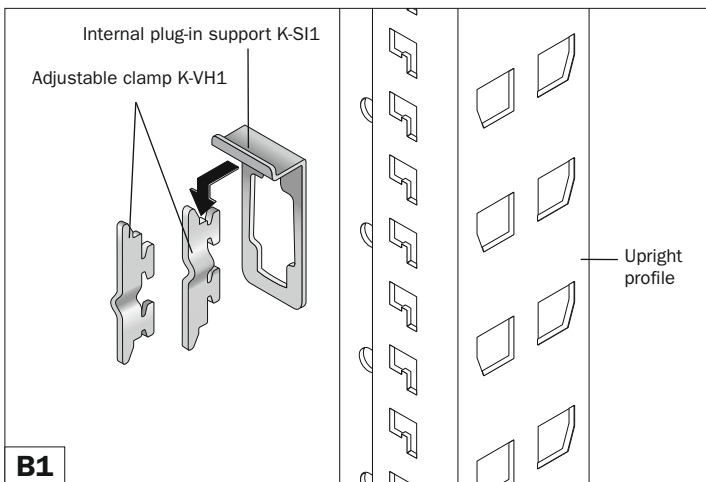

7.4.3 Attaching the rear side profiles for upright profiles P 63 and P 65

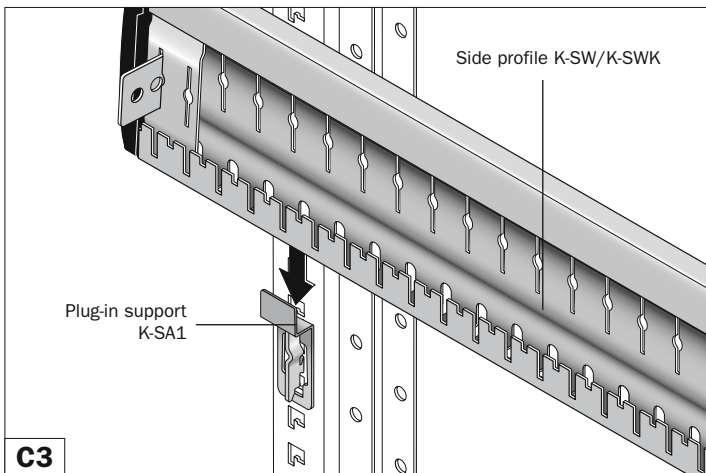
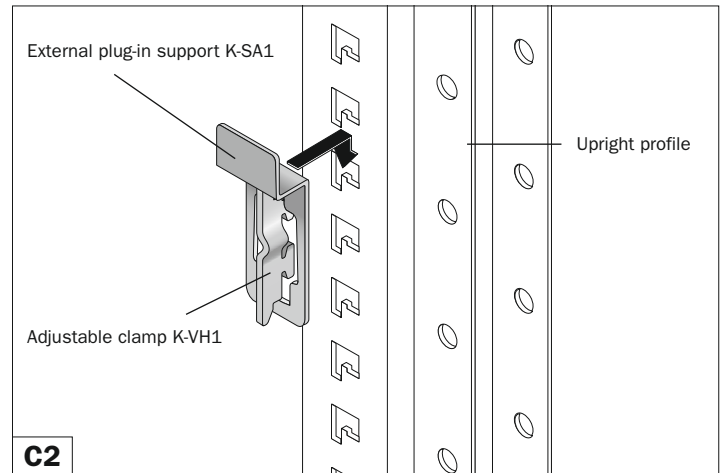
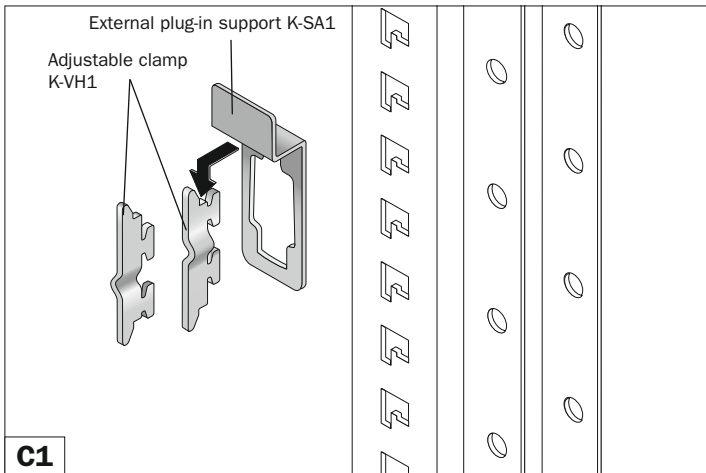

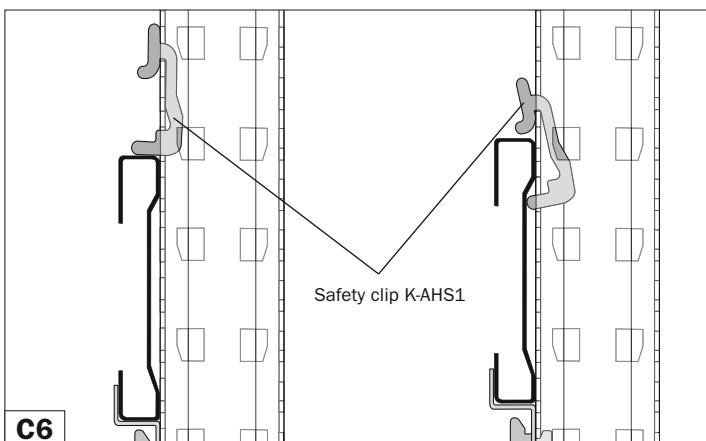
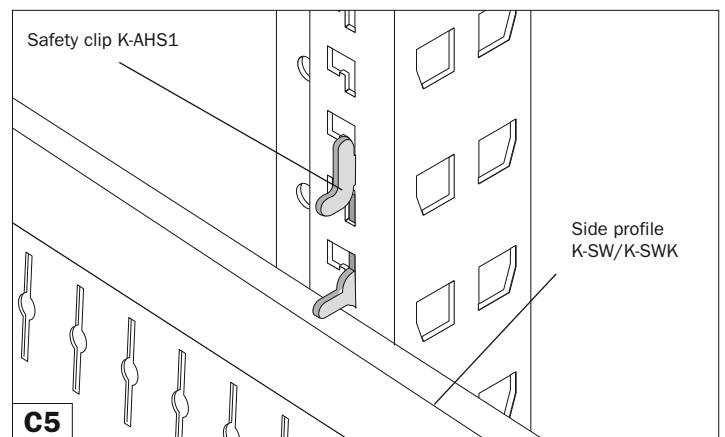
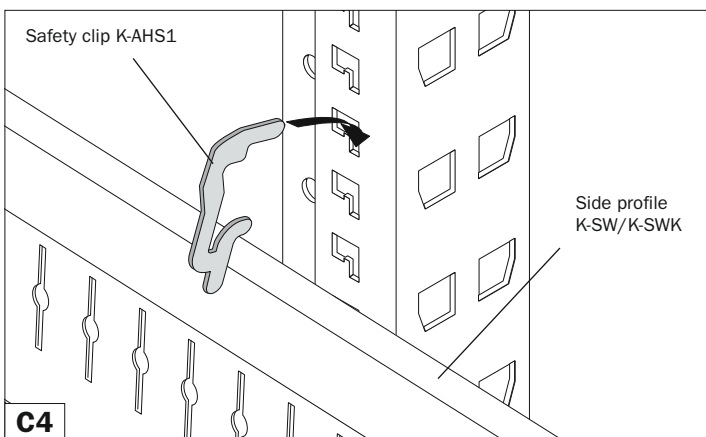

7.4.4 Safety clips for upright profiles P 63 and P 65

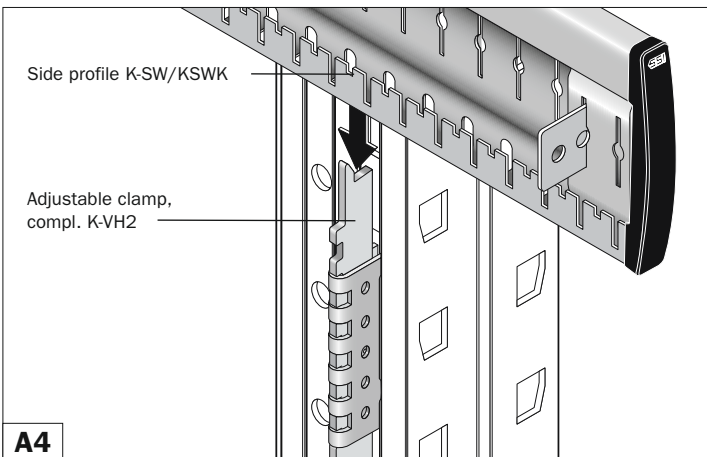
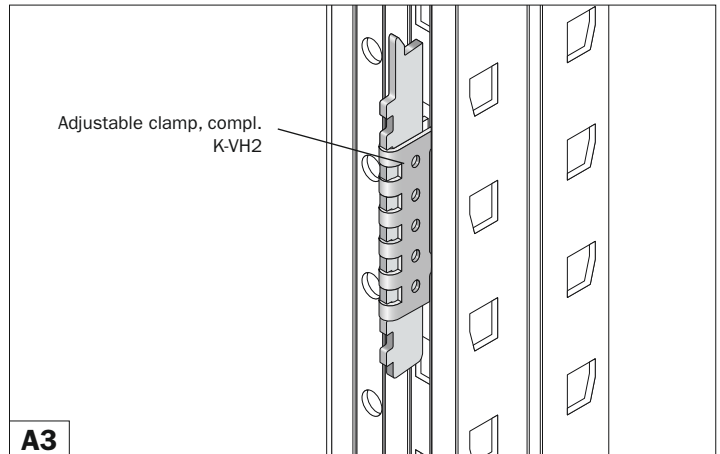
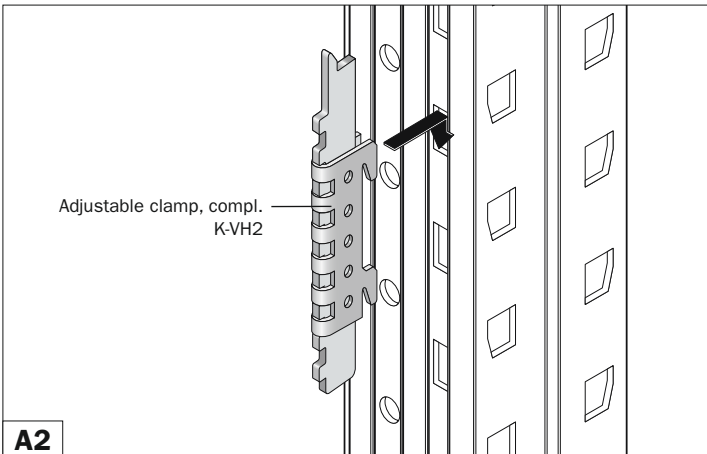
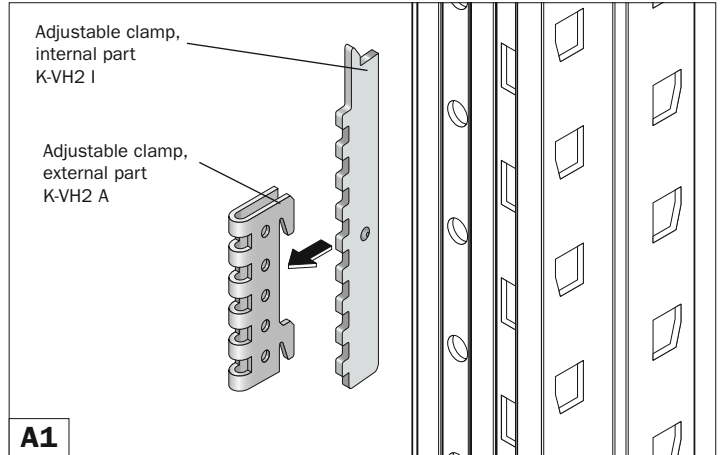
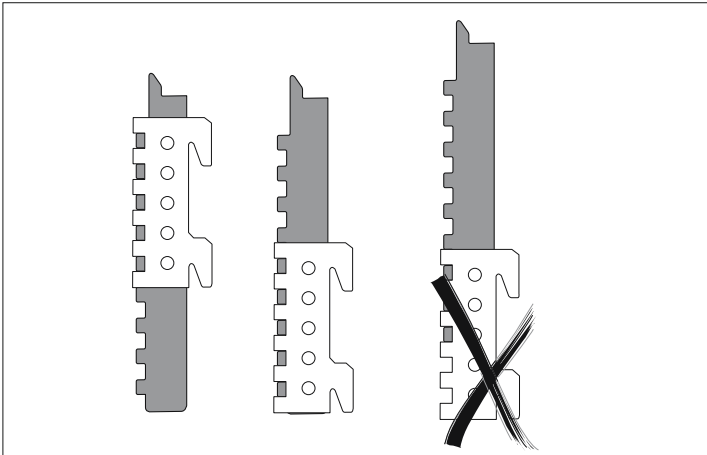

Each flow bed frame contains two safety clips. These are fitted at the rear or against the tilt direction.

7.4.5 Attaching the front side profiles for upright profiles P 73, P 93, P 95, P 13 and P 15



 **The adjustable clamp (external part) must be toothed complete with the adjustable clamp (internal part) and must not project outwards.**

7.4.6 Attaching the internal side profiles for upright profiles P 73, P 93, P 95, P 13 and P 15

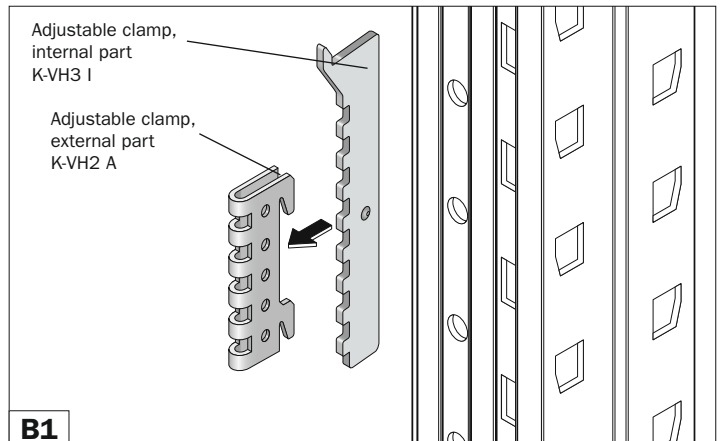
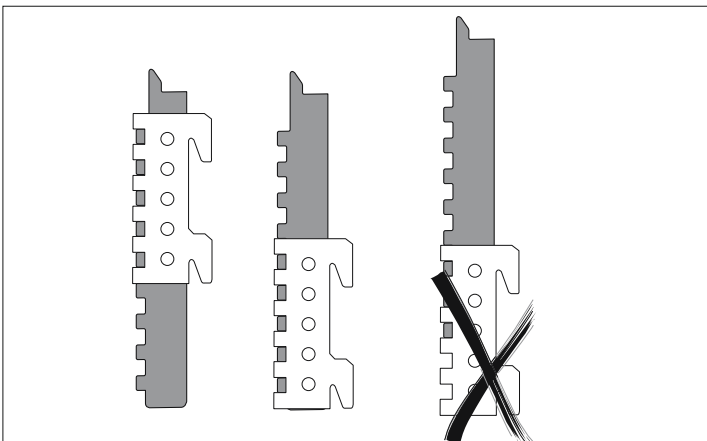

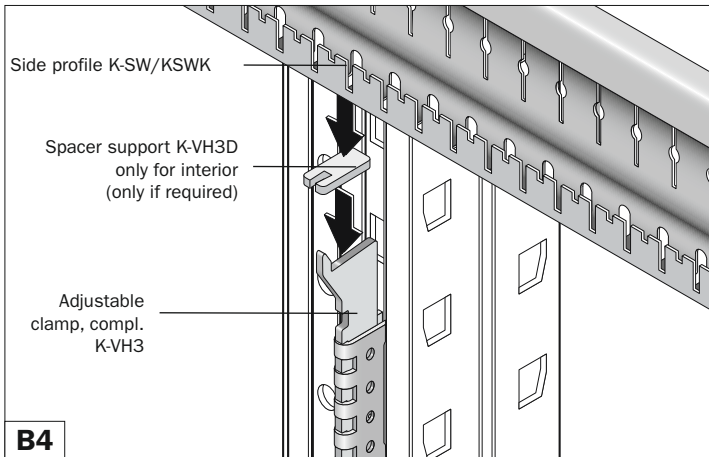
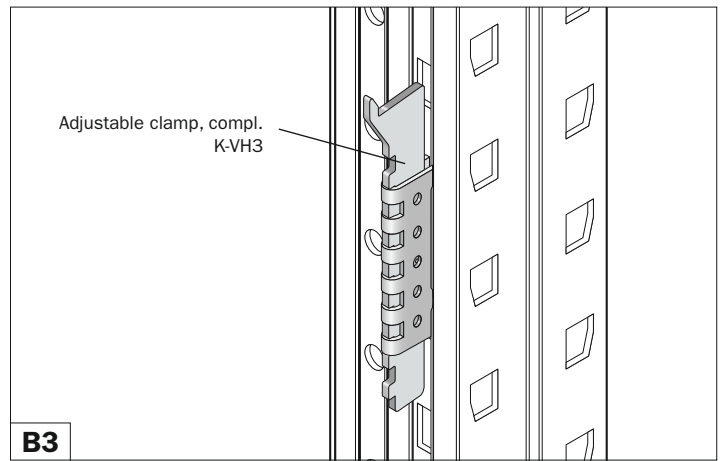
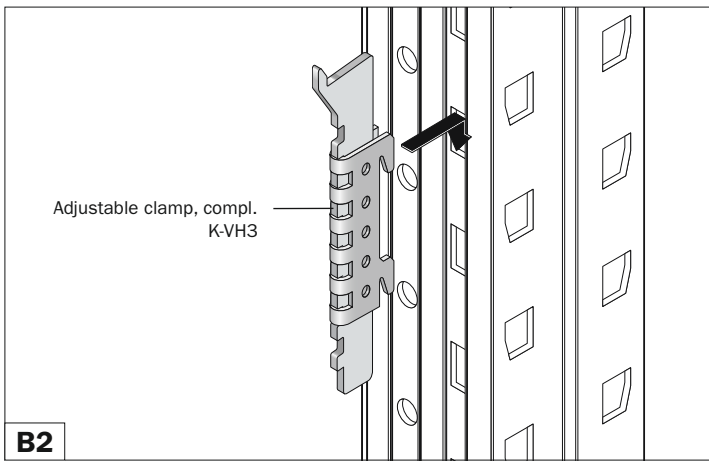

 **The adjustable clamp (external part) must be toothed complete with the adjustable clamp (internal part) and must not project outwards.**

7.4.7 Attaching the rear side profiles for upright profiles P 73, P 93, P 95, P 13 and P 15

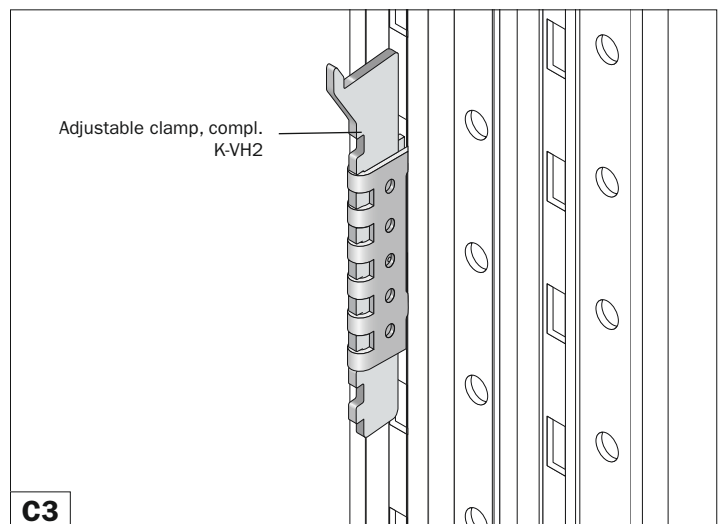
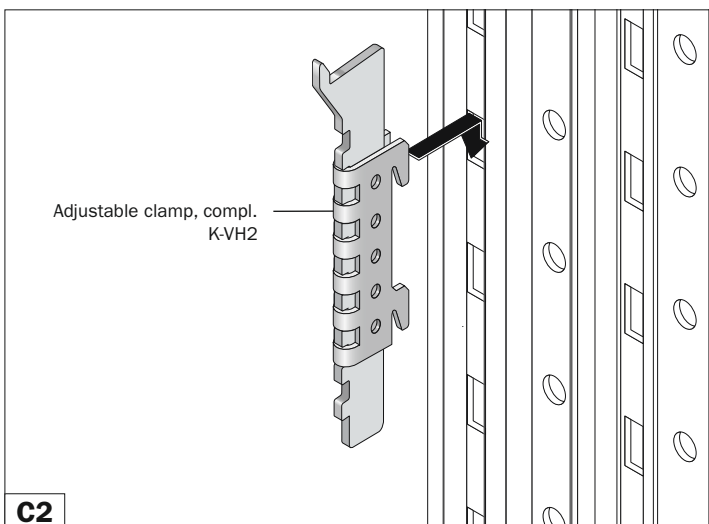
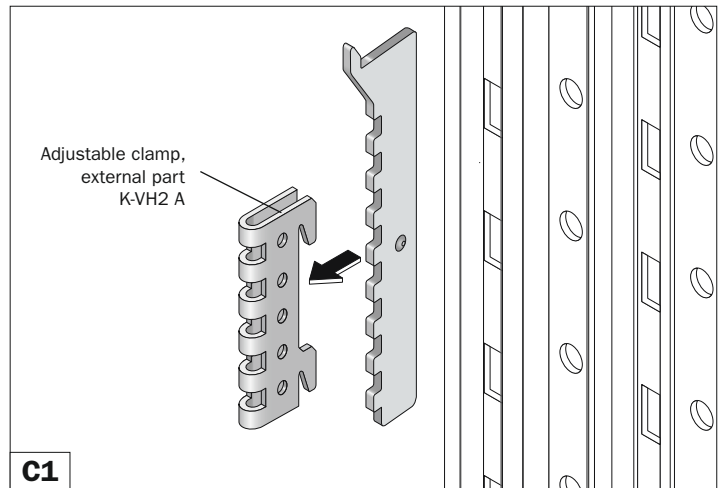
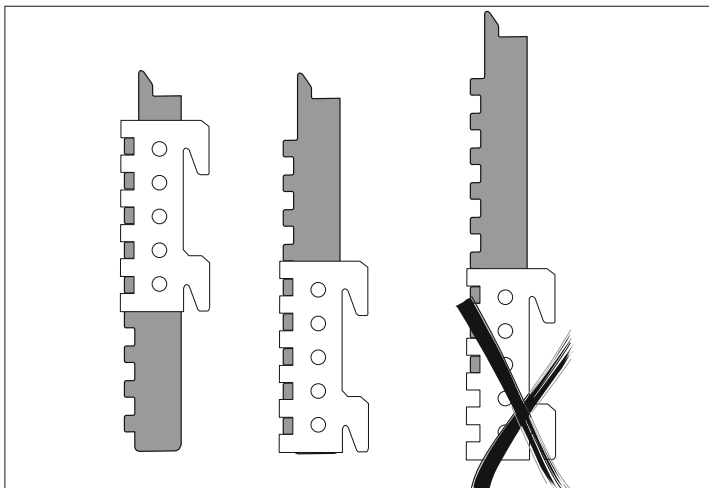

7.4.8 Safety clip

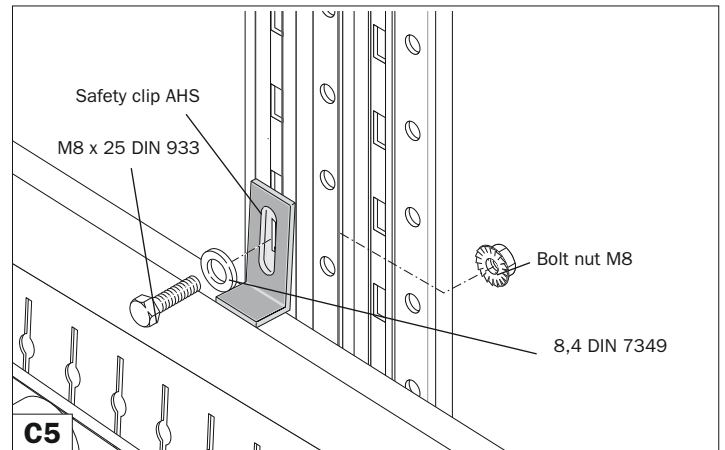
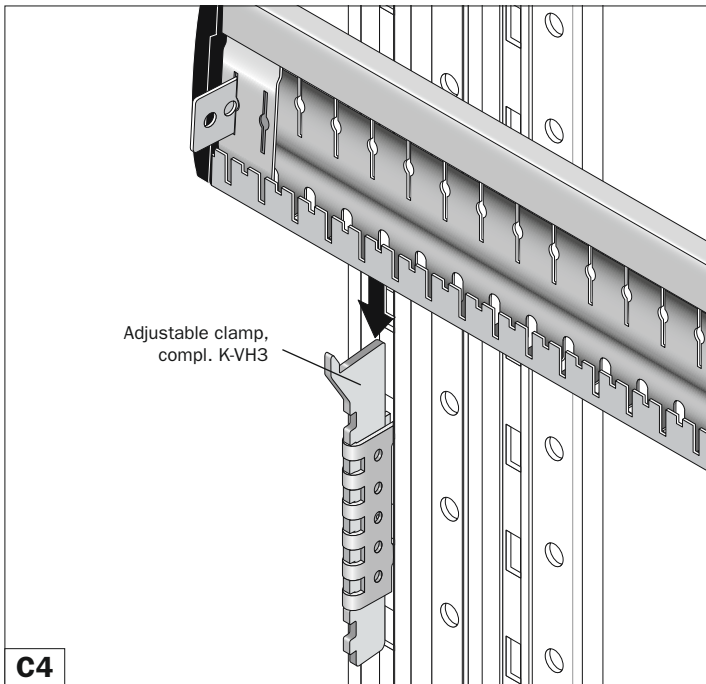

The adjustable clamp (external part) must be toothed complete with the adjustable clamp (internal part) and must not project outwards.

Each flow bed frame contains two safety clips. These are fitted at the rear or against the tilt direction.

7.5 Overview of flow bed frame

7.5.1 Overview of flat flow bed frame

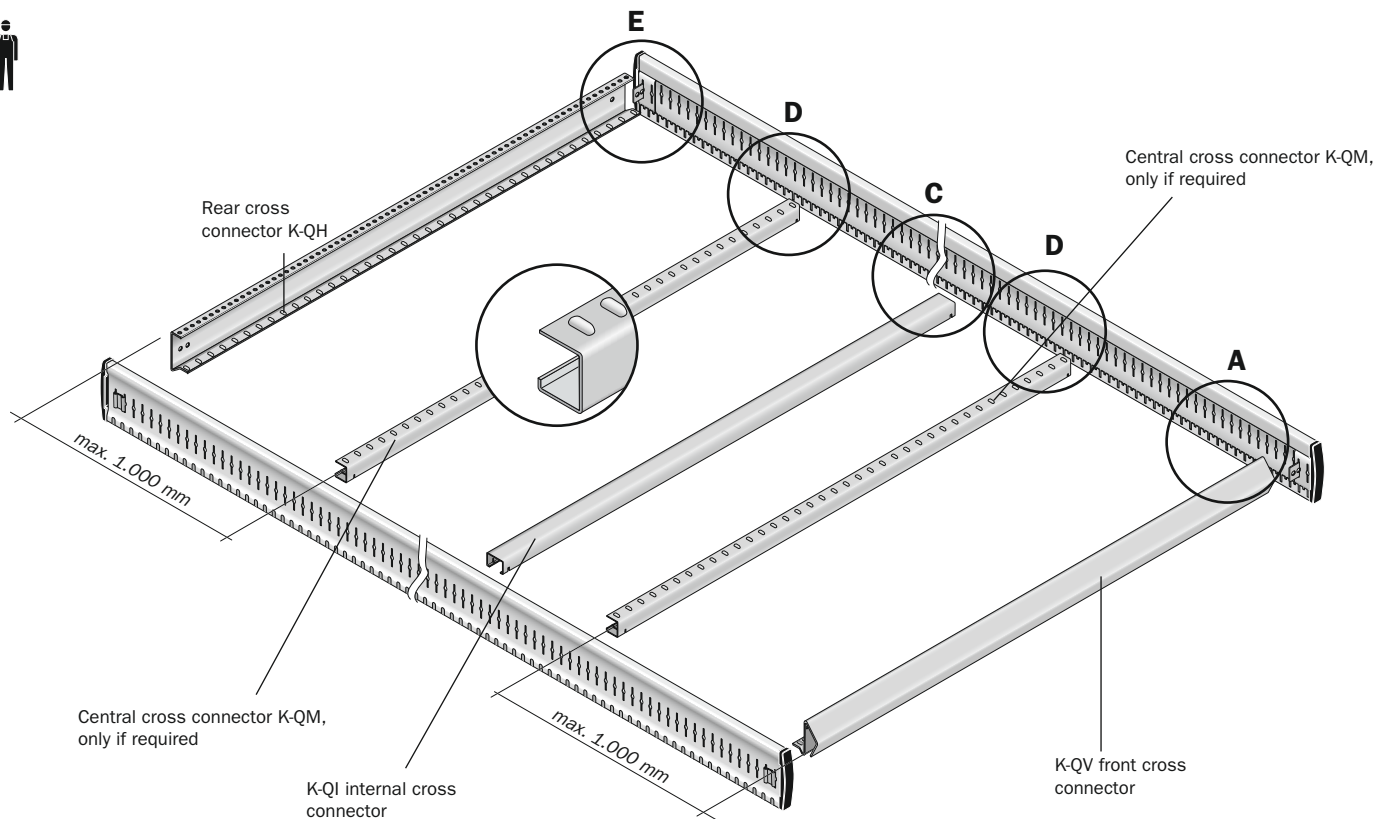

7.5.2 Overview of flat/tilted flow bed frame

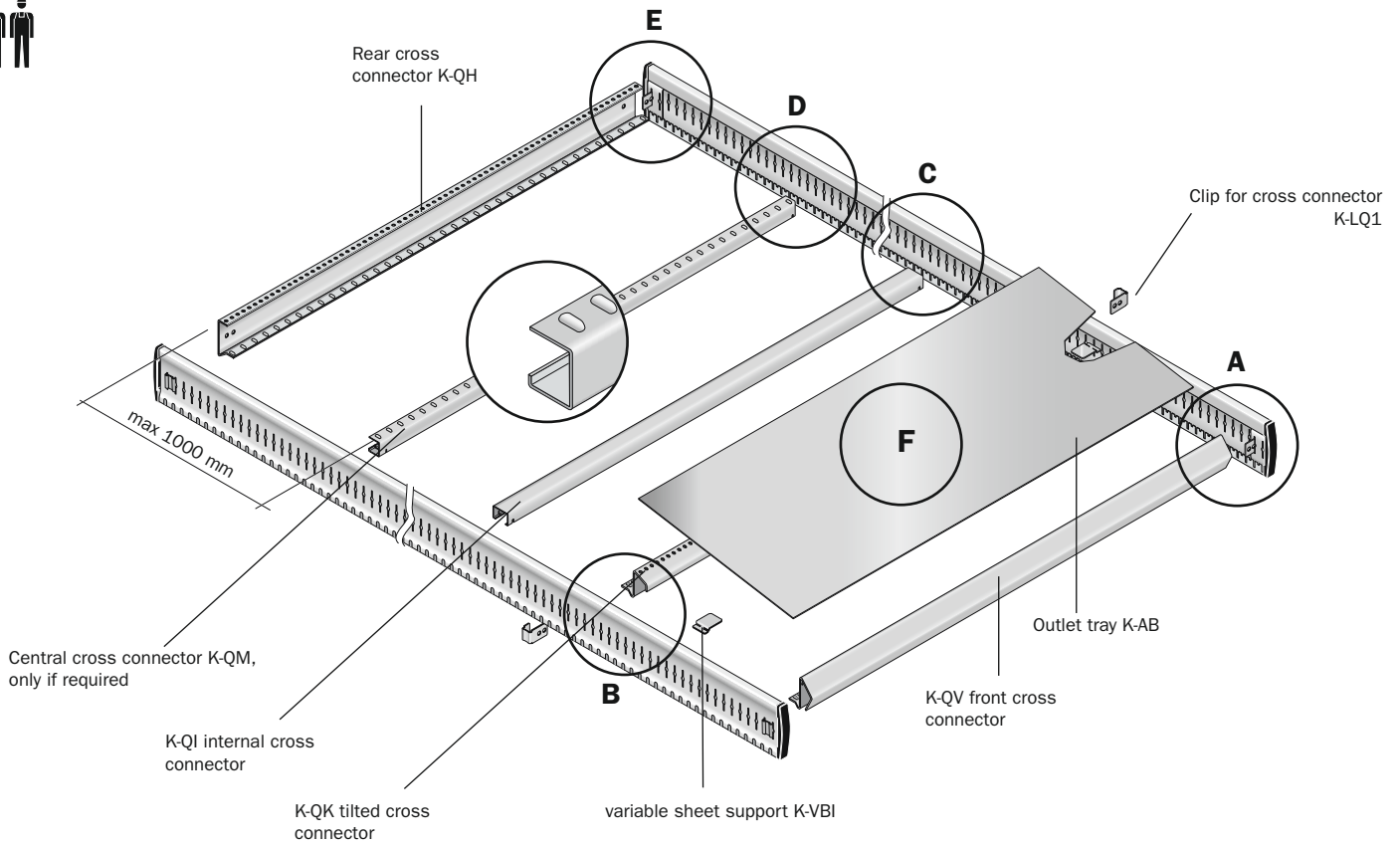

7.5.3 Overview of tilted flow bed frame

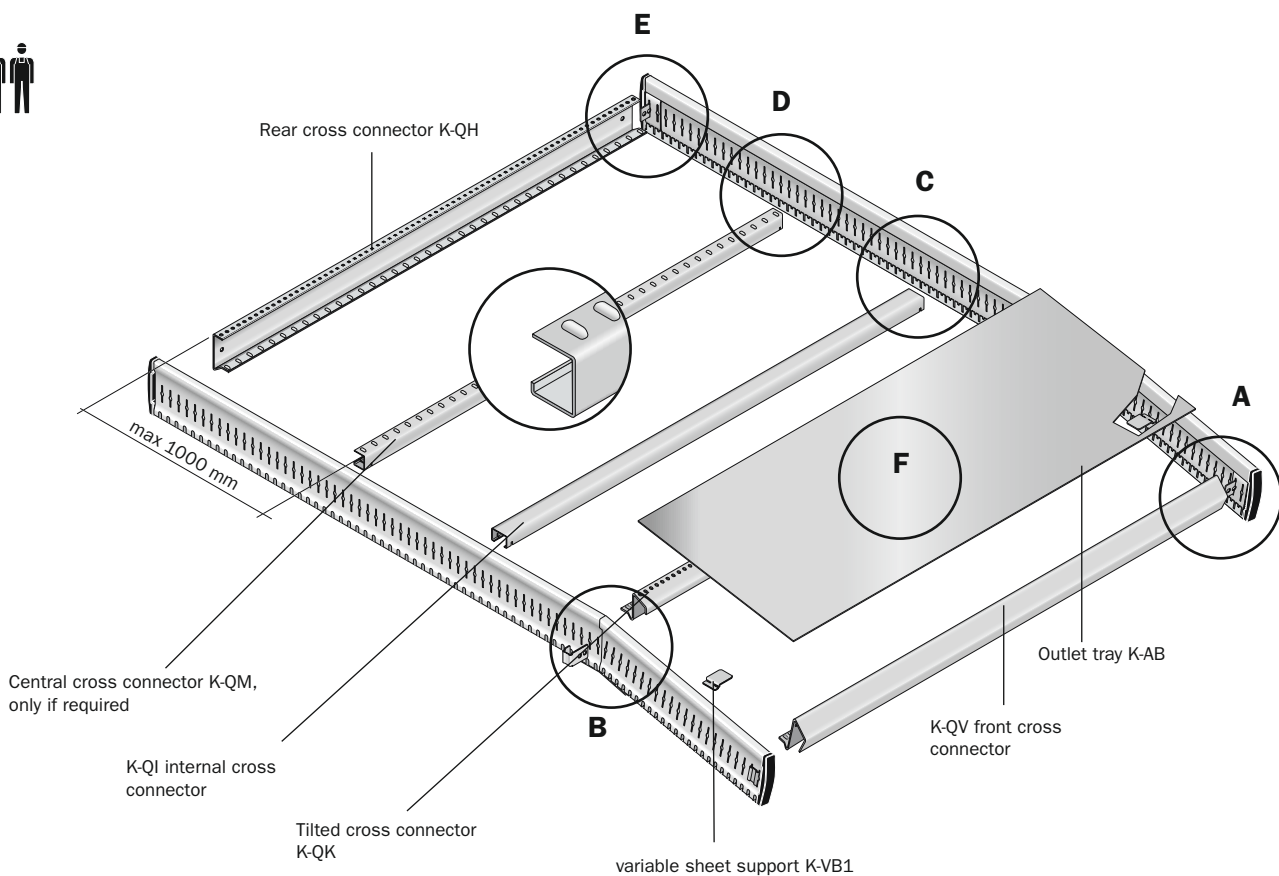

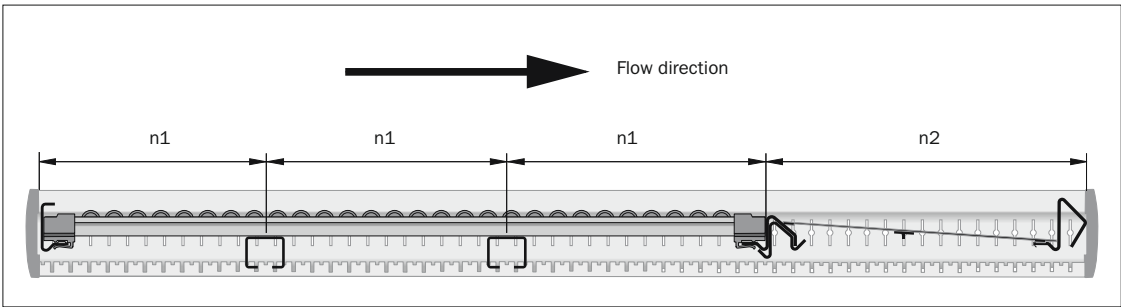

A diagram is included with each flow bed frame. This diagram gives the positions, quantity and type of the cross connectors as well as the flow bed frame load.

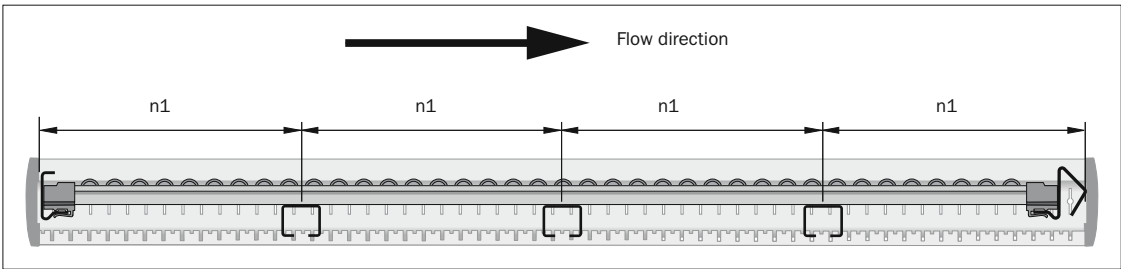
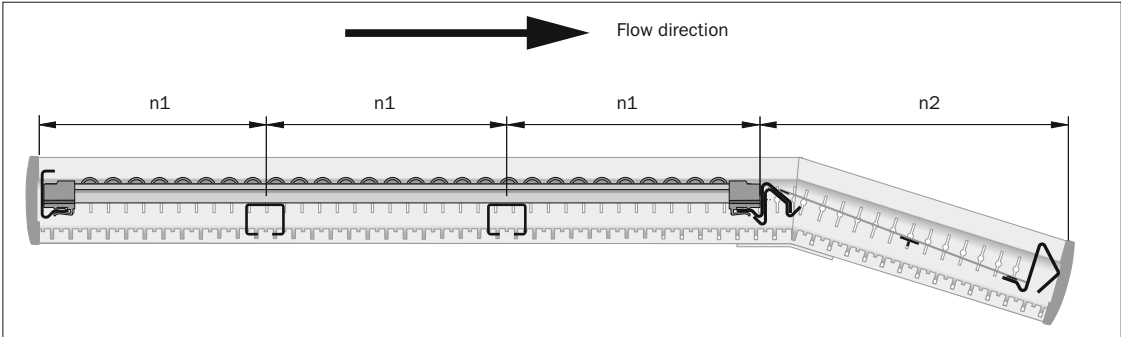

7.6 Assembly of the flow bed frame

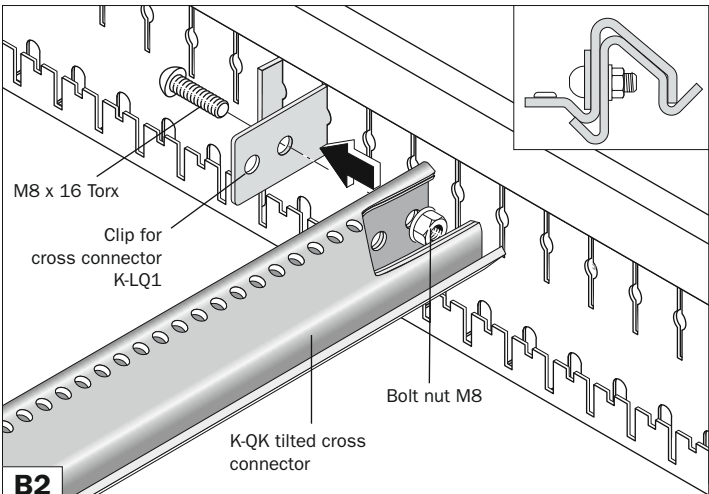
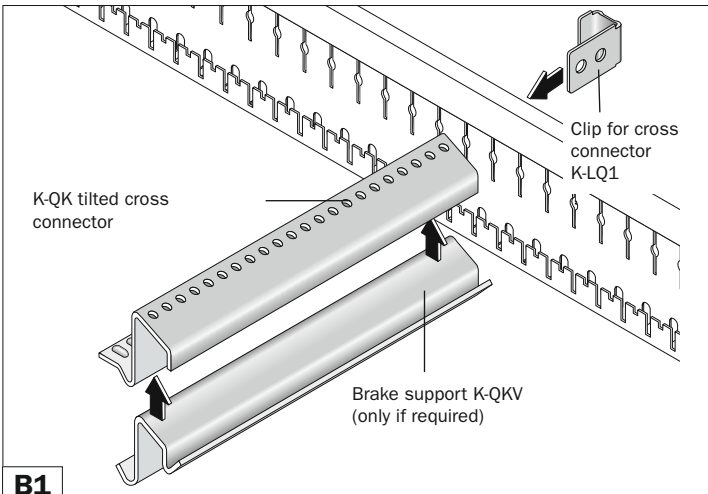
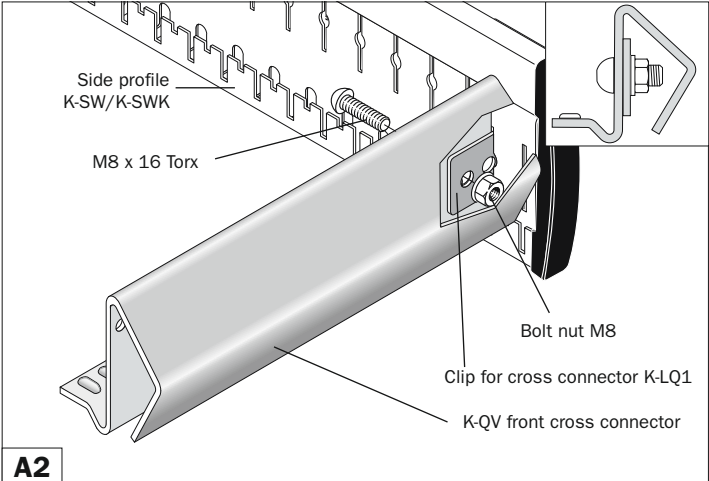
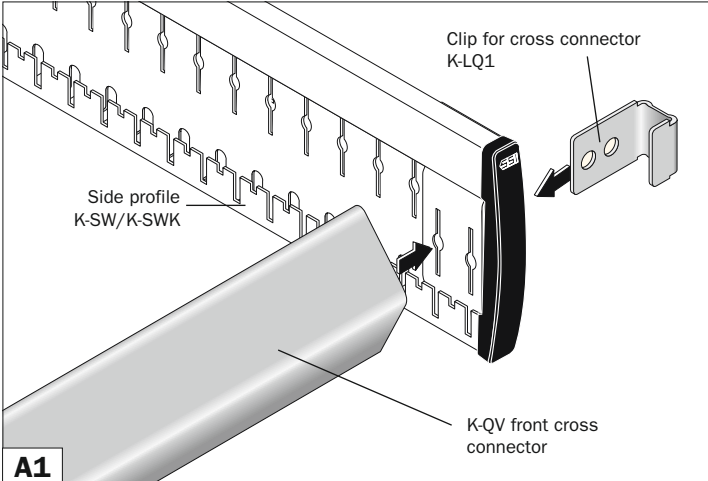

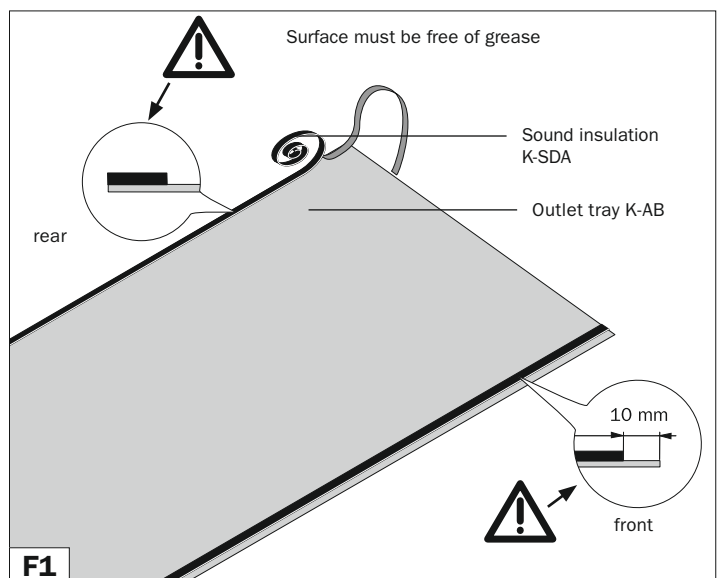
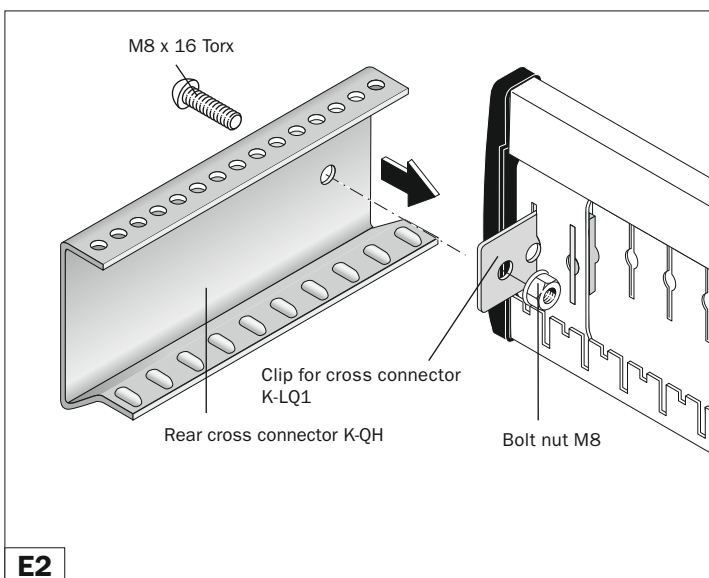
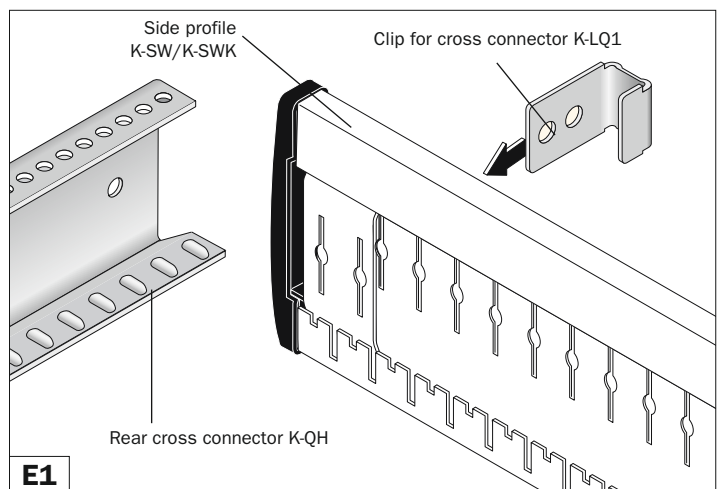
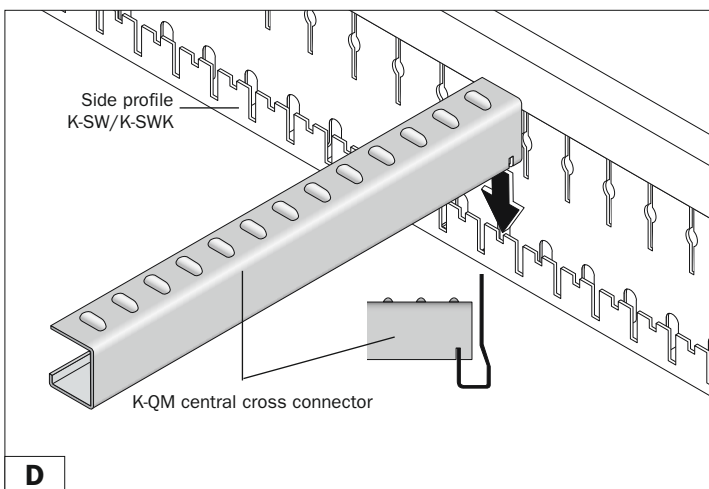
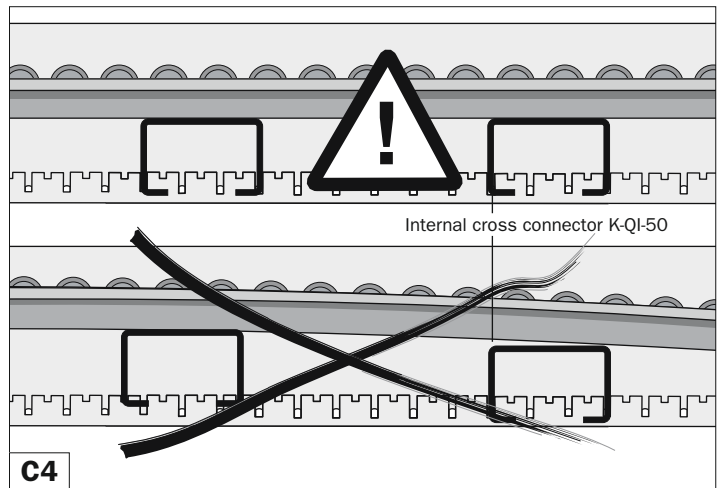
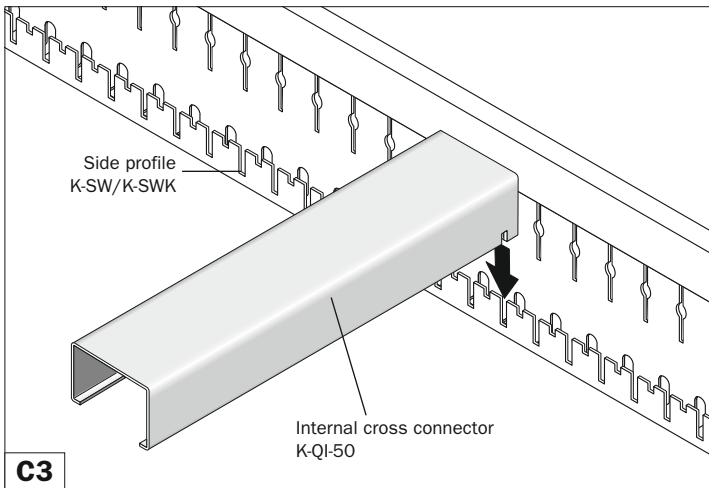
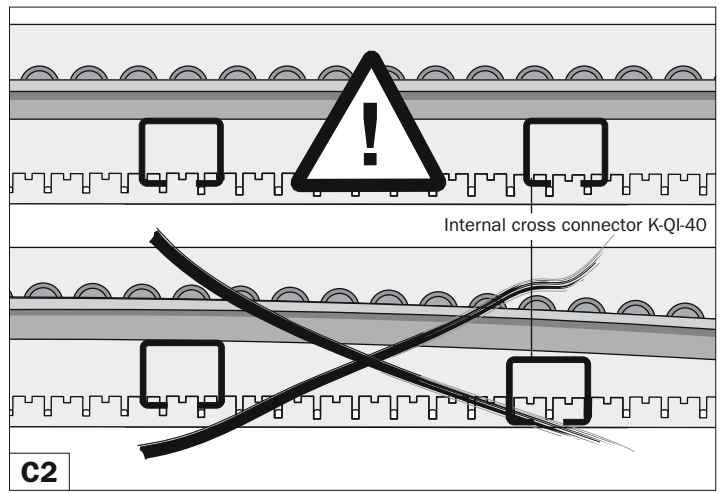
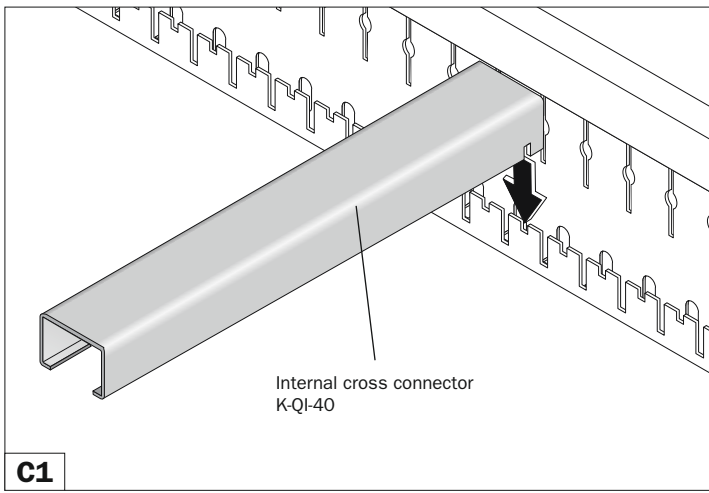

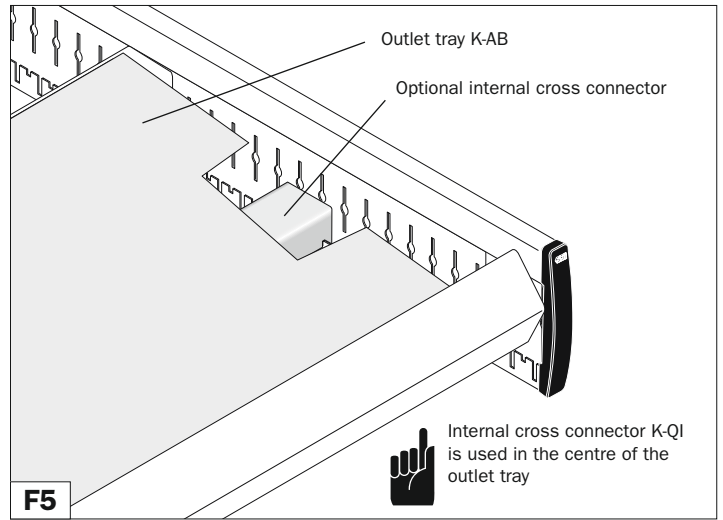
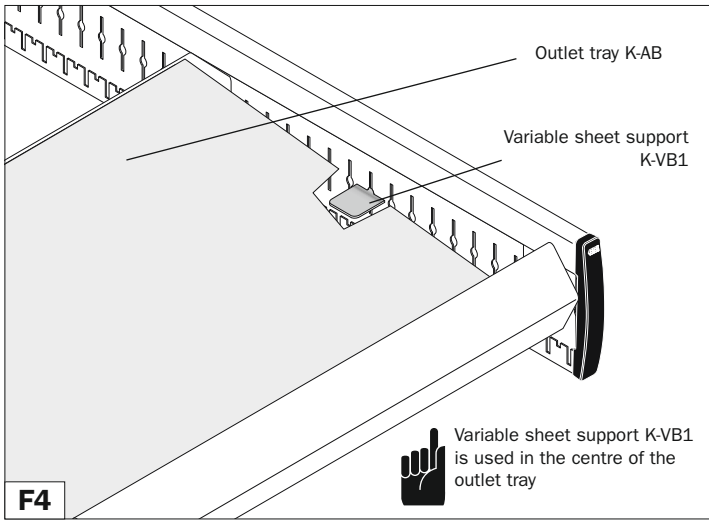
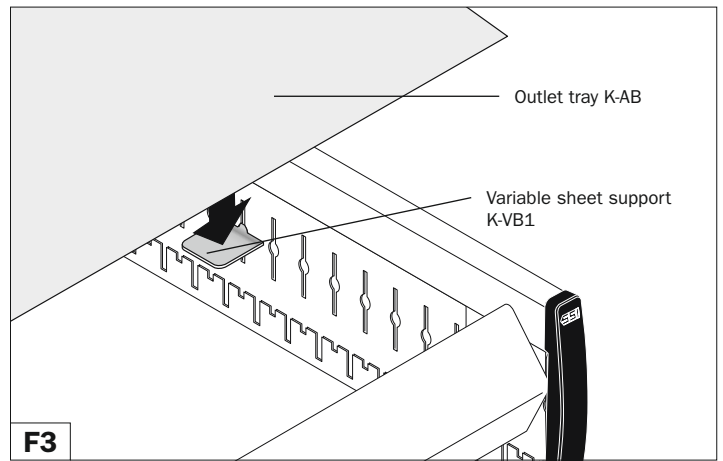
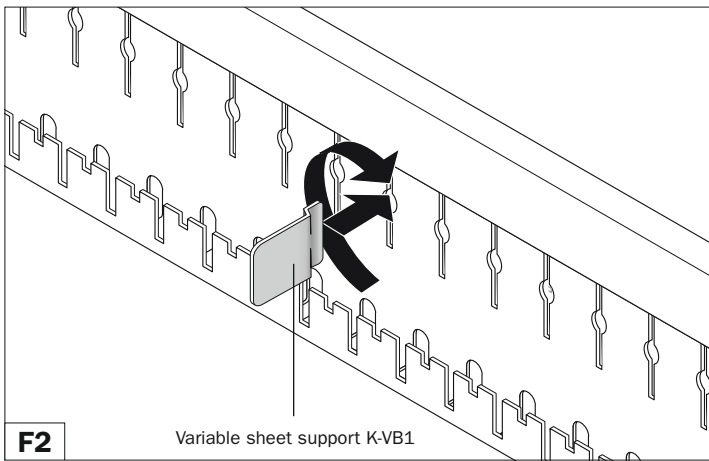

7.7 Assembly of step cross connectors

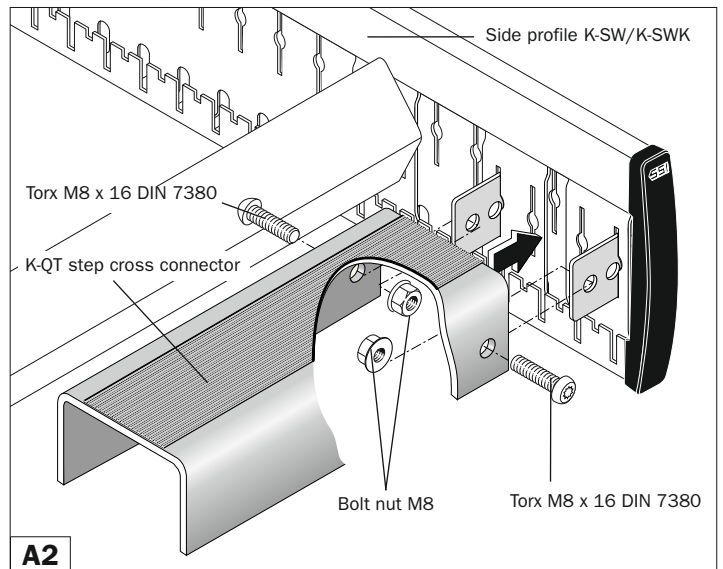
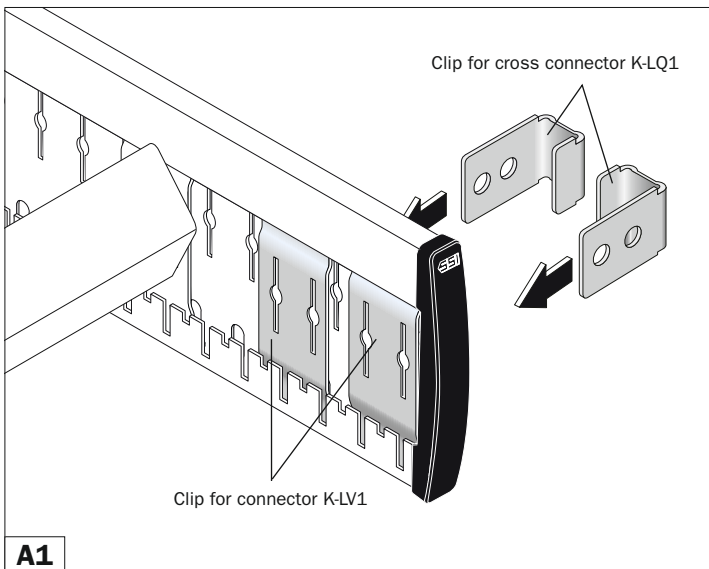
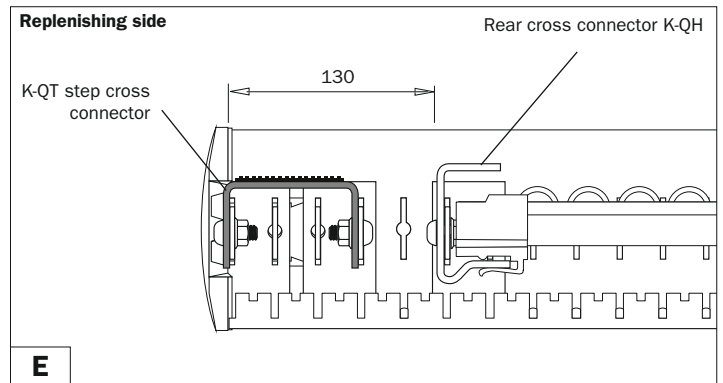
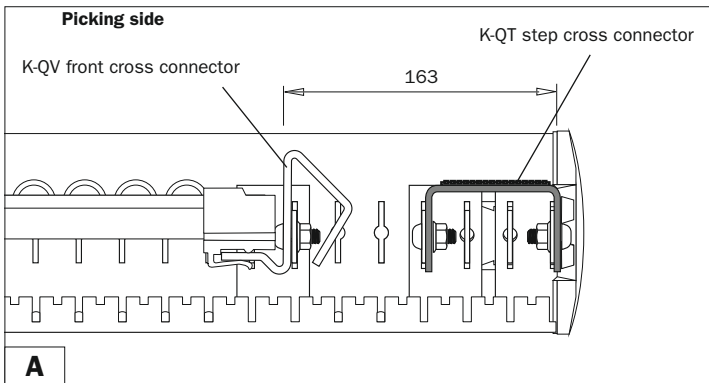

7.8 Assembly of roller tracks, standard and retractable sashes

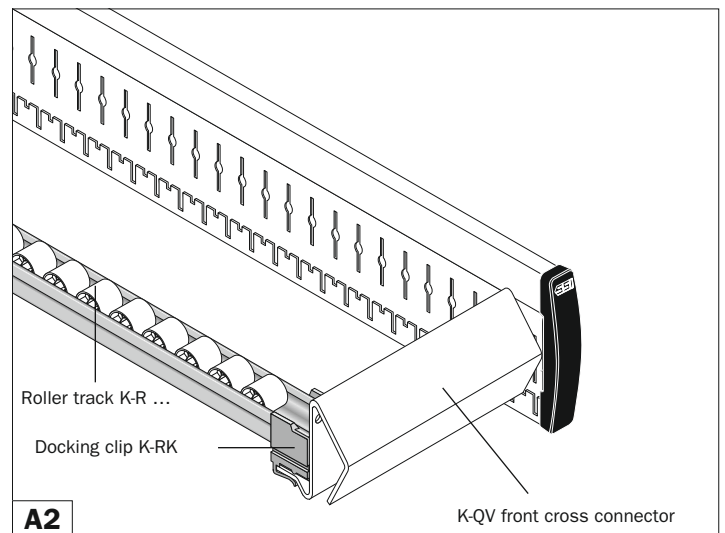
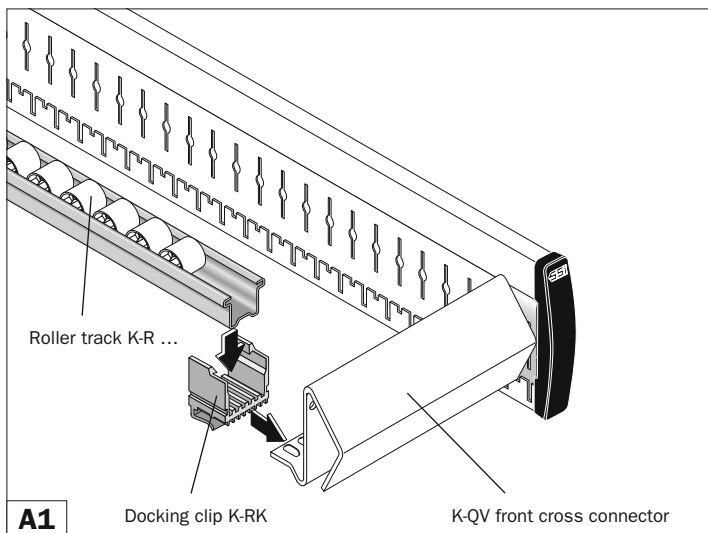
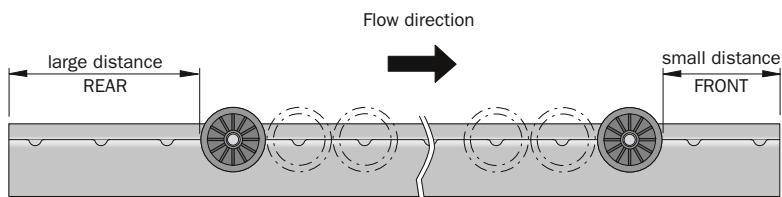
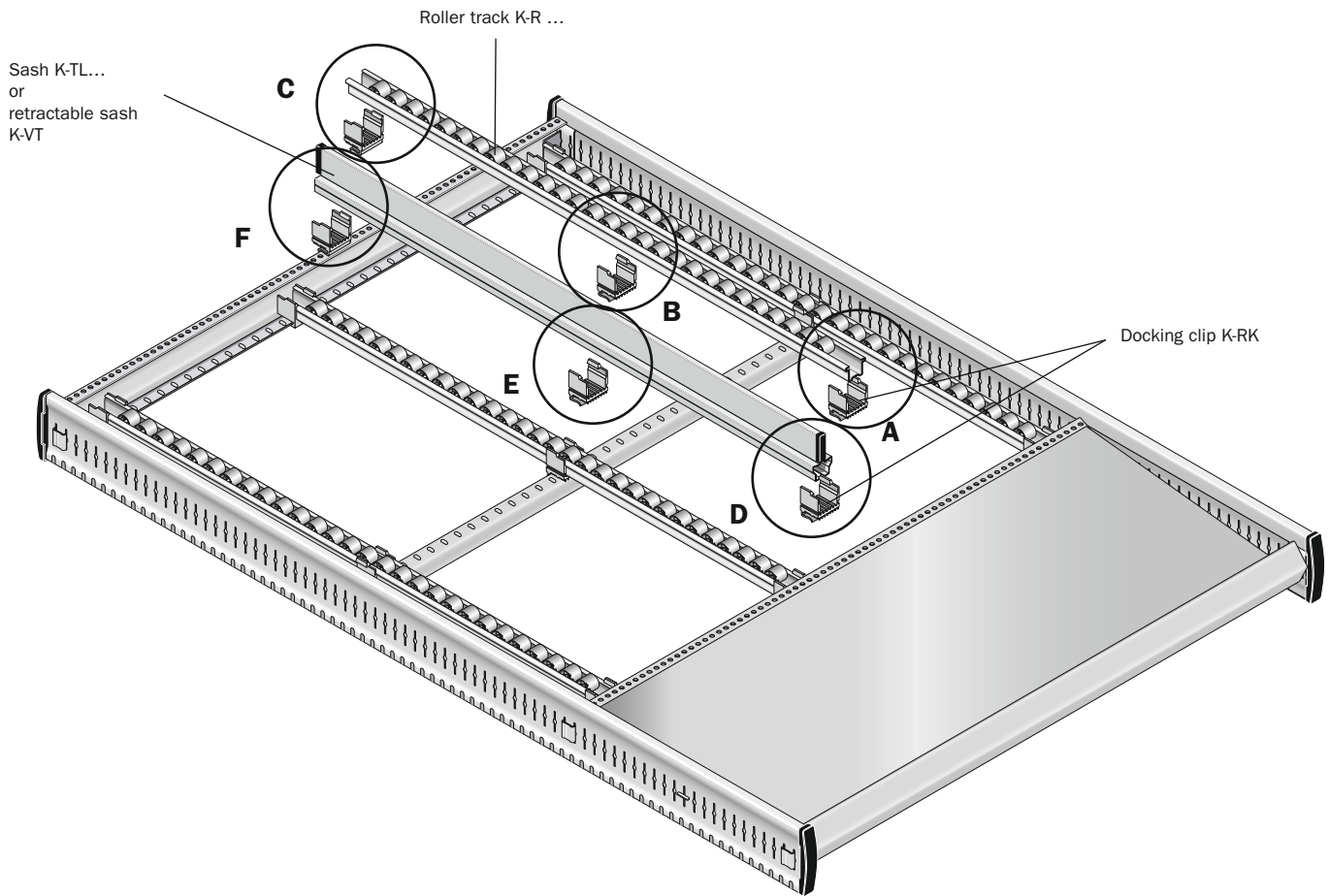

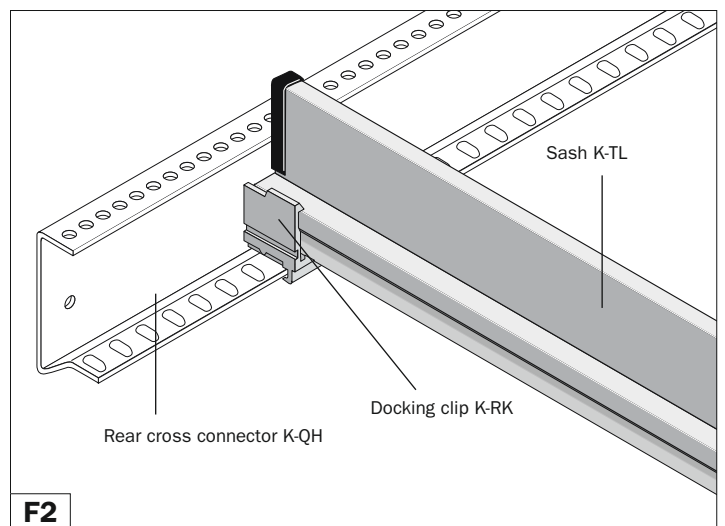
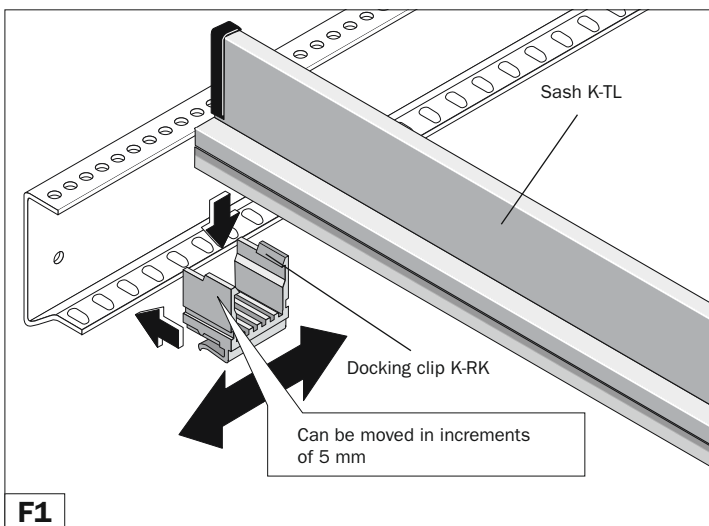
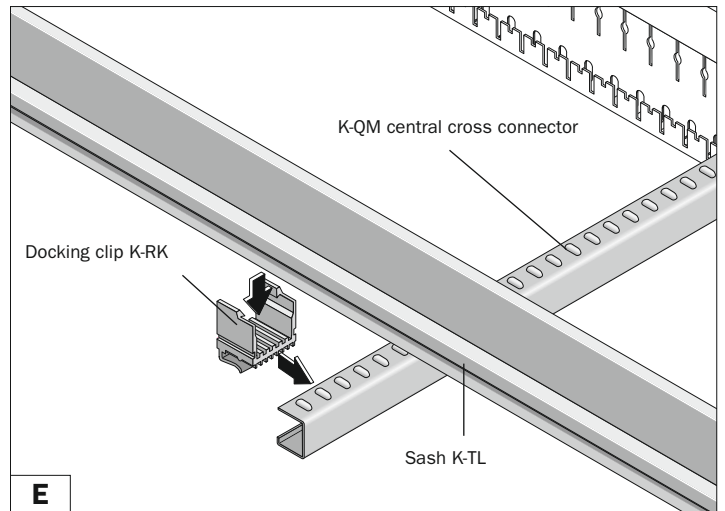
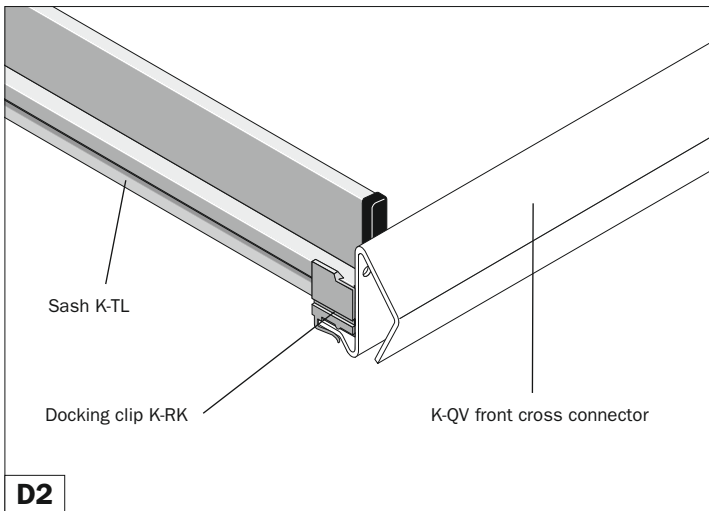
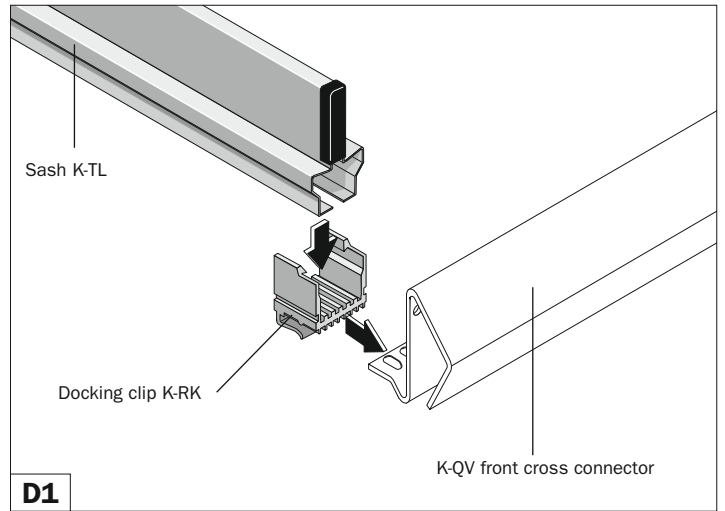
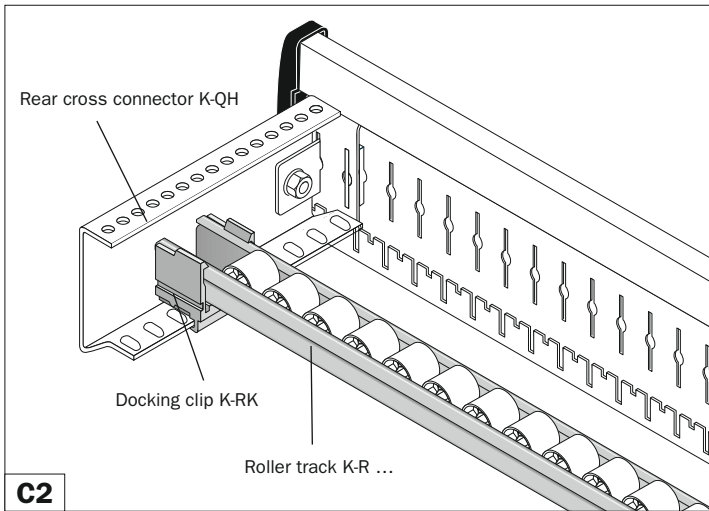
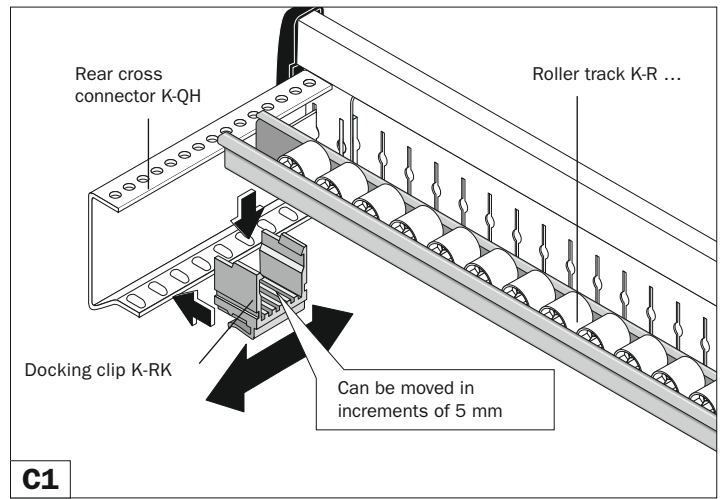
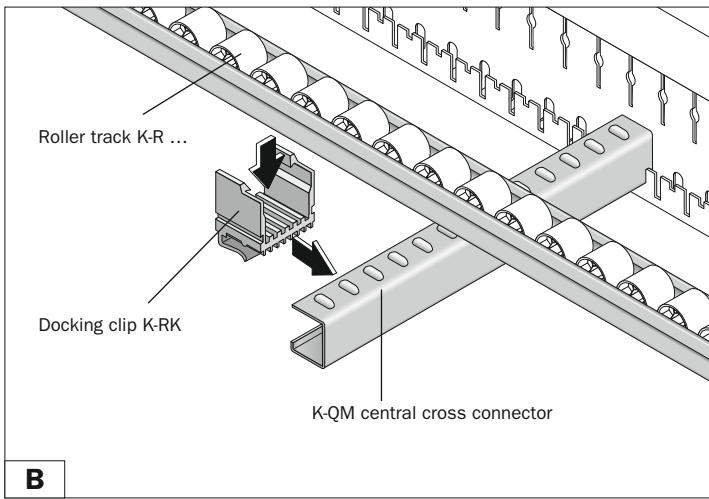

7.9 Assembly of retractable sashes

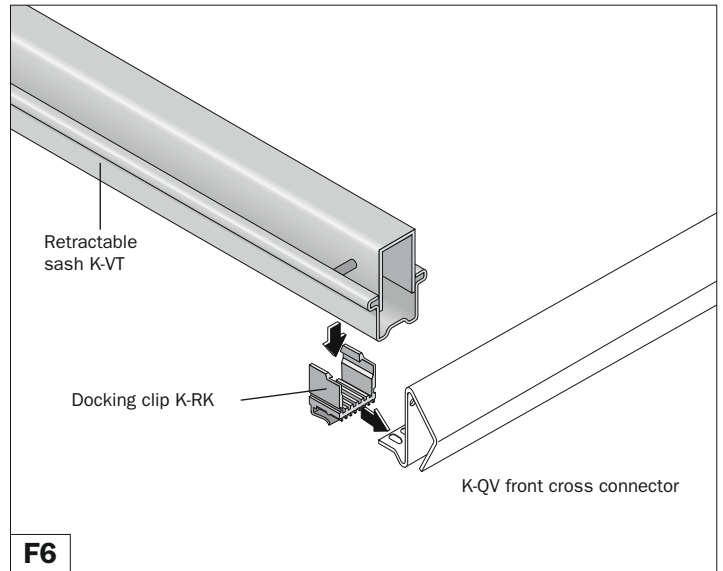
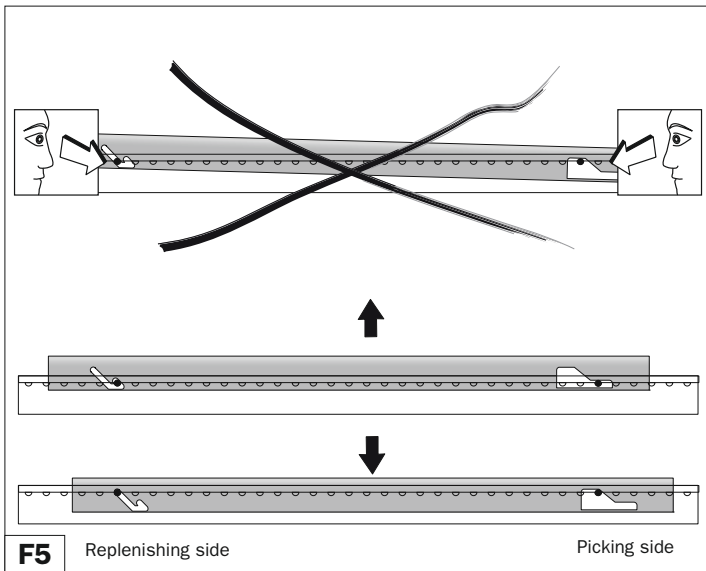
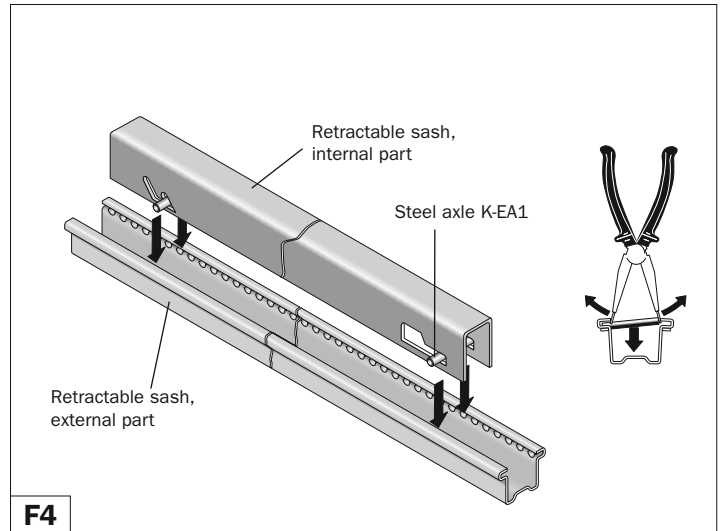
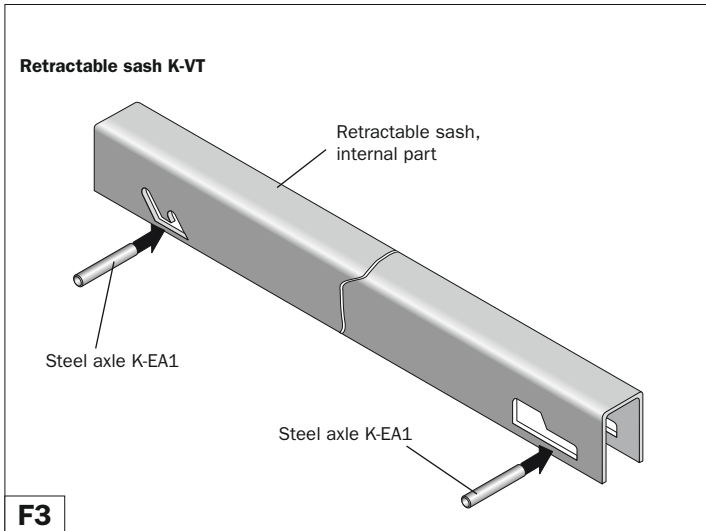

7.10 Assembly of multiplex sashes and guide rails

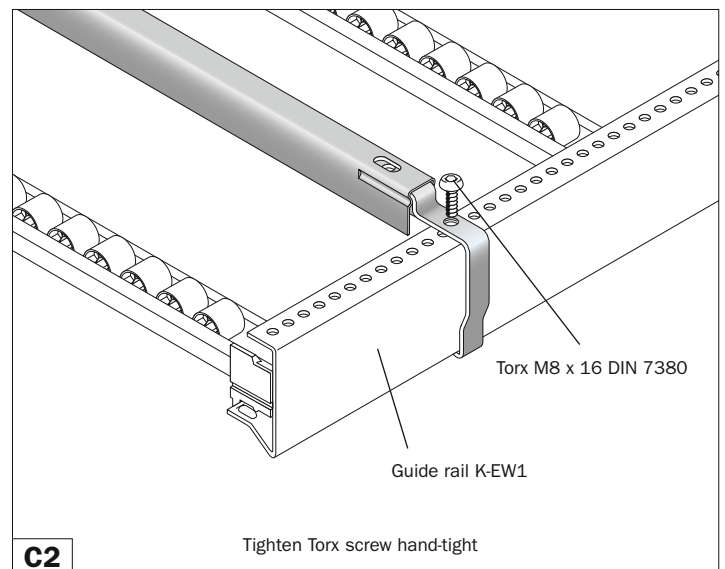
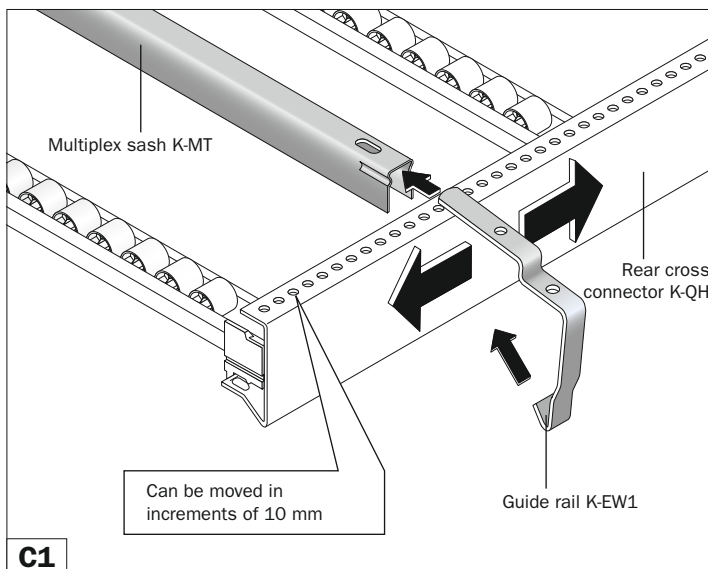
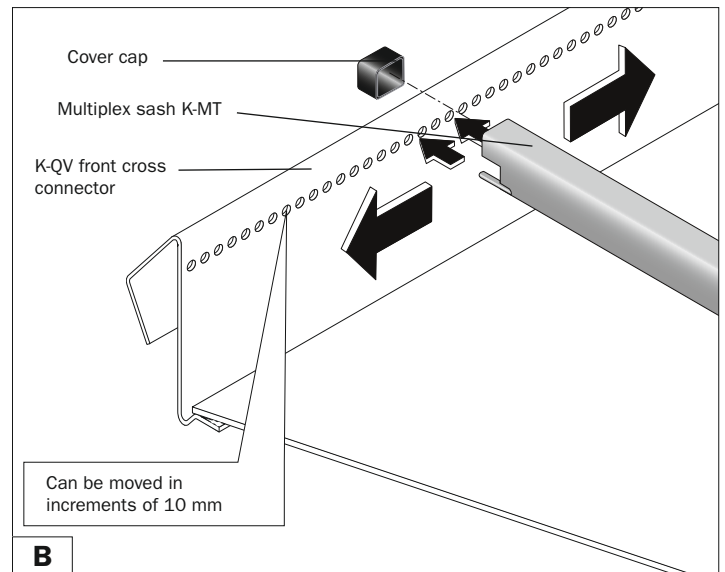
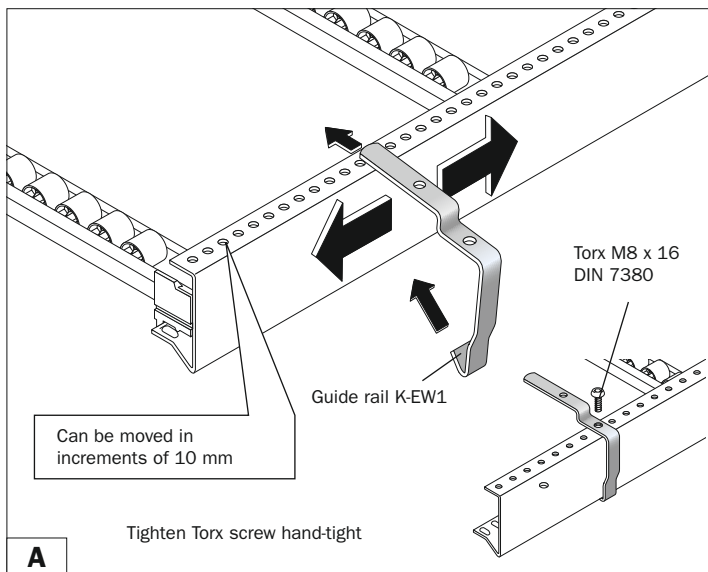
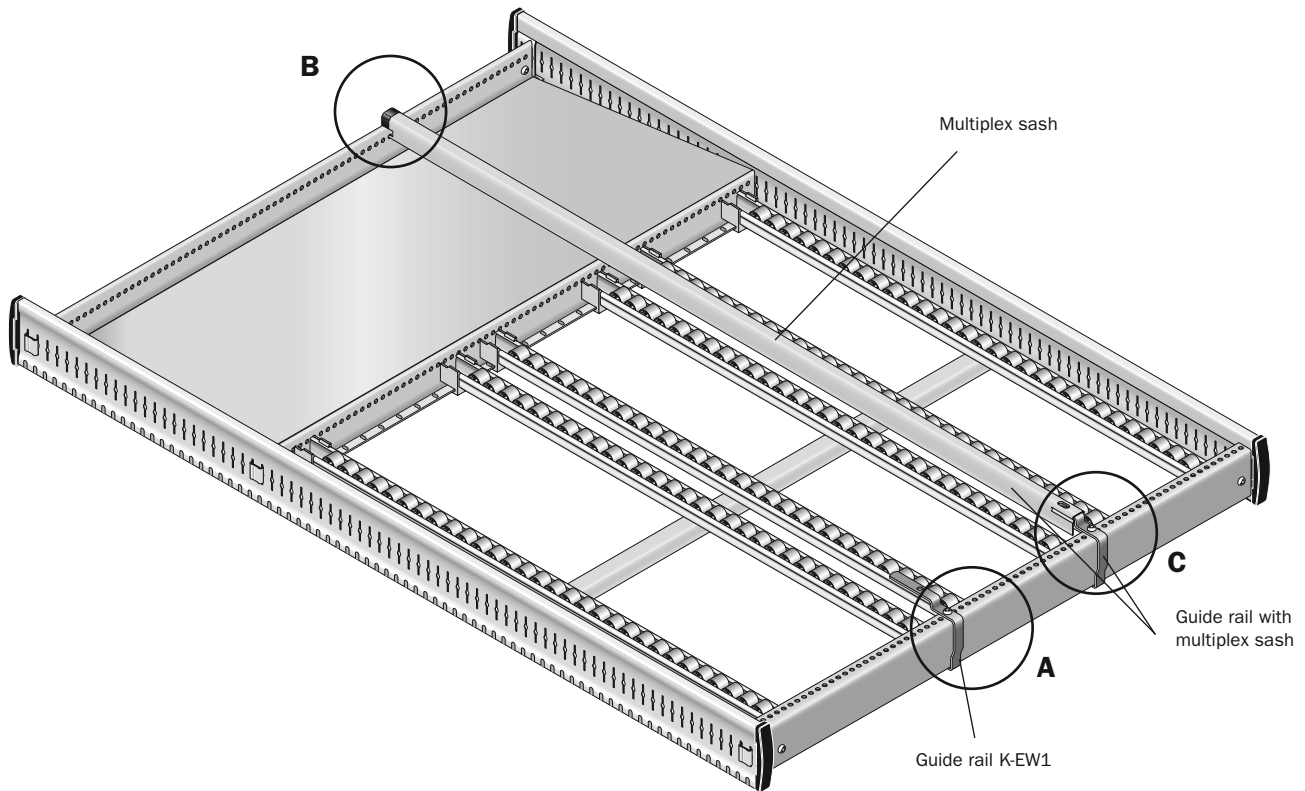

8.0 Assembly of accessories

8.1 Assembly of braking strips

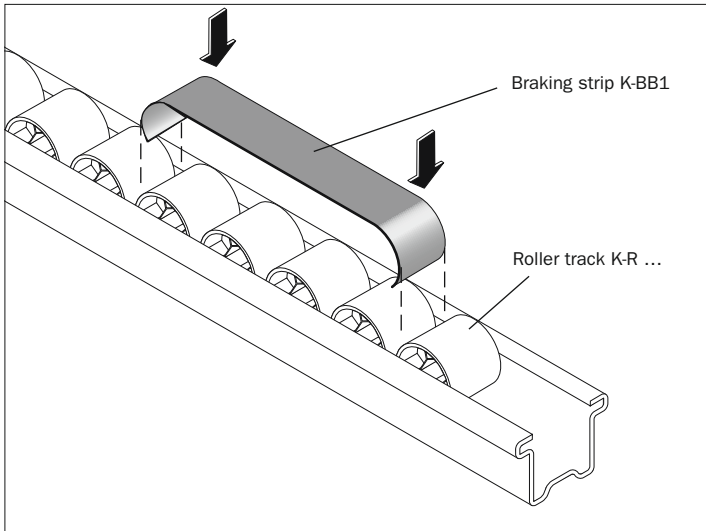

8.2 Assembly of braking clips

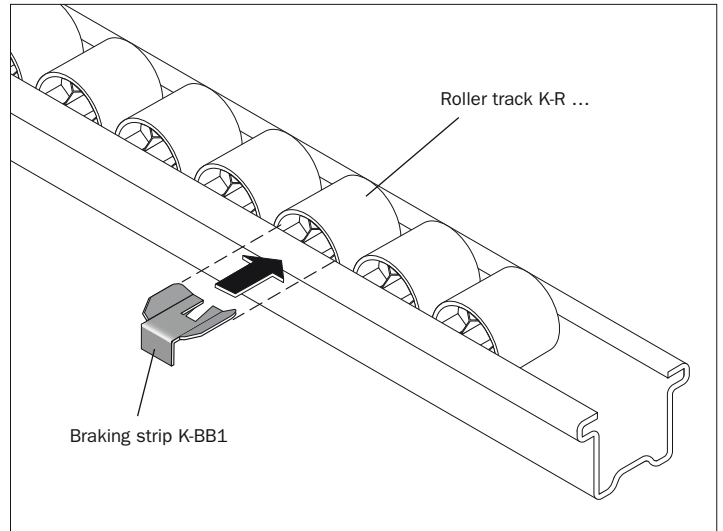

8.3 Assembly of expanding locks

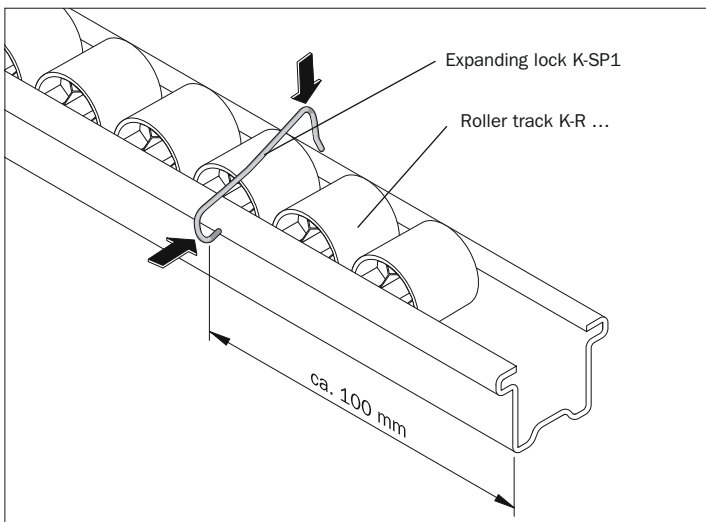

8.4 Assembly of step beads

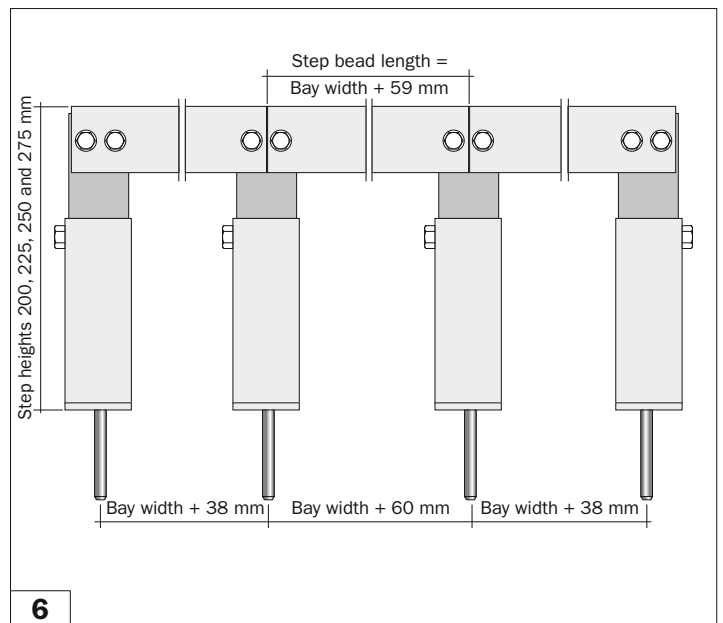
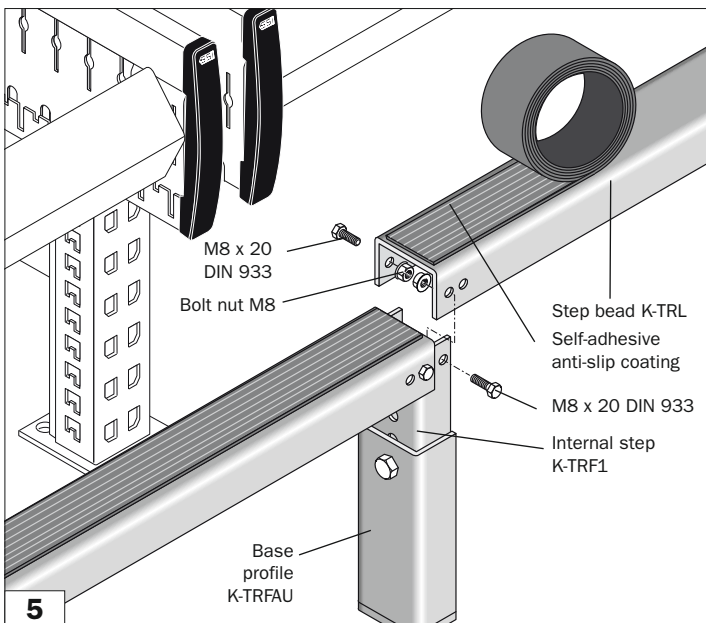
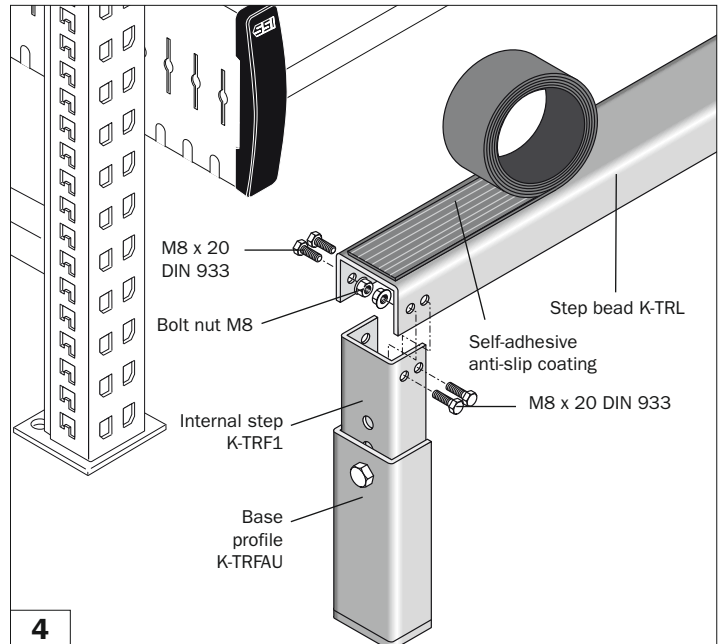
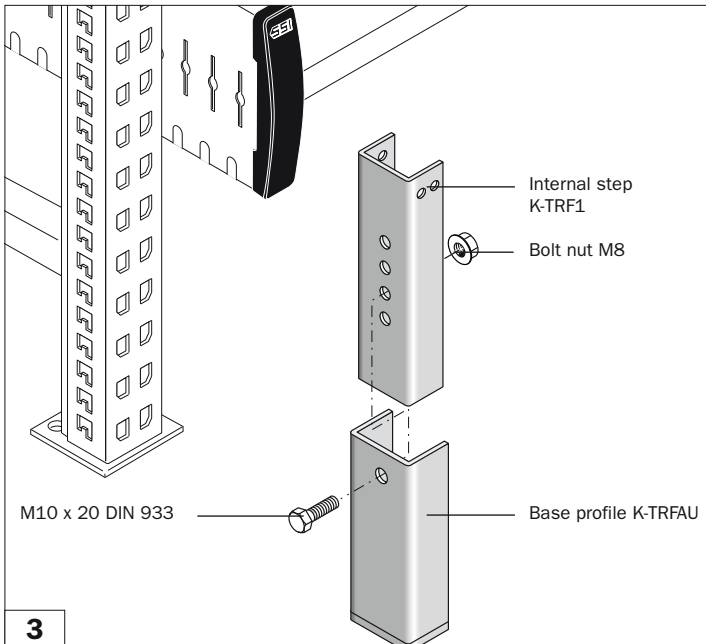
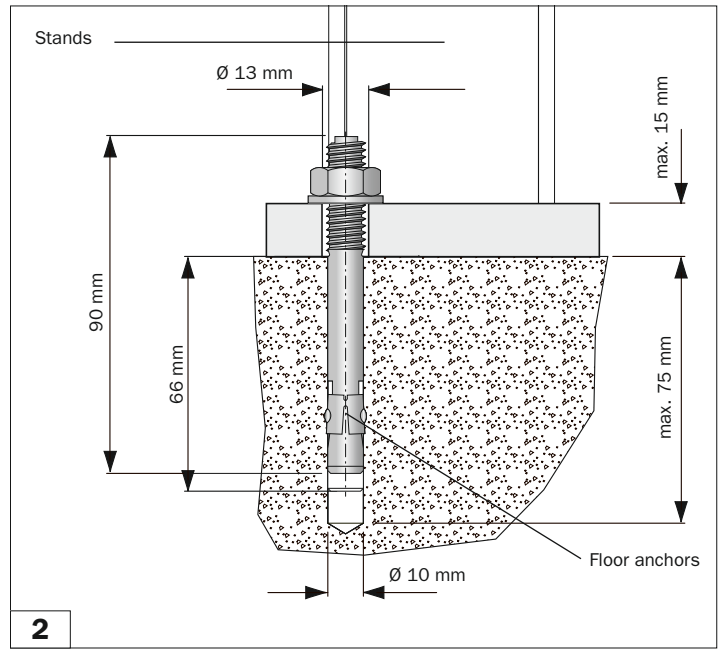
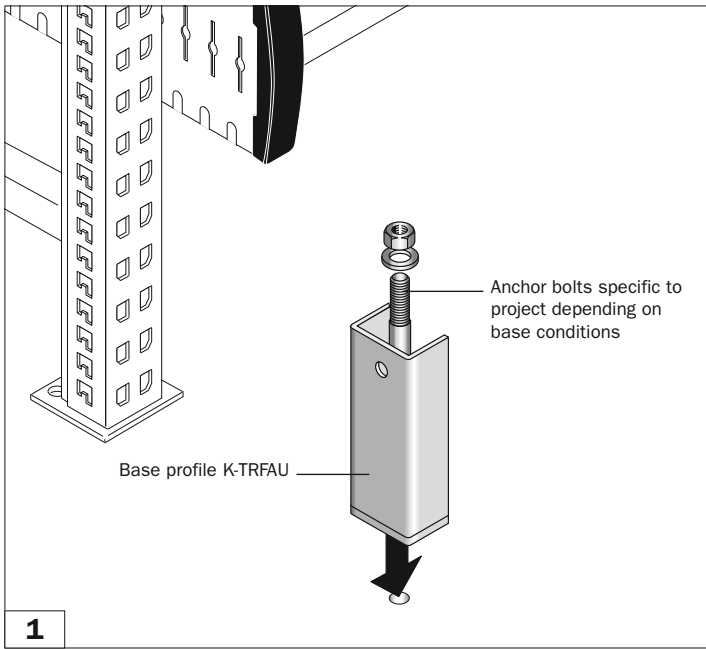

8.5 Assembly of transport roller tracks

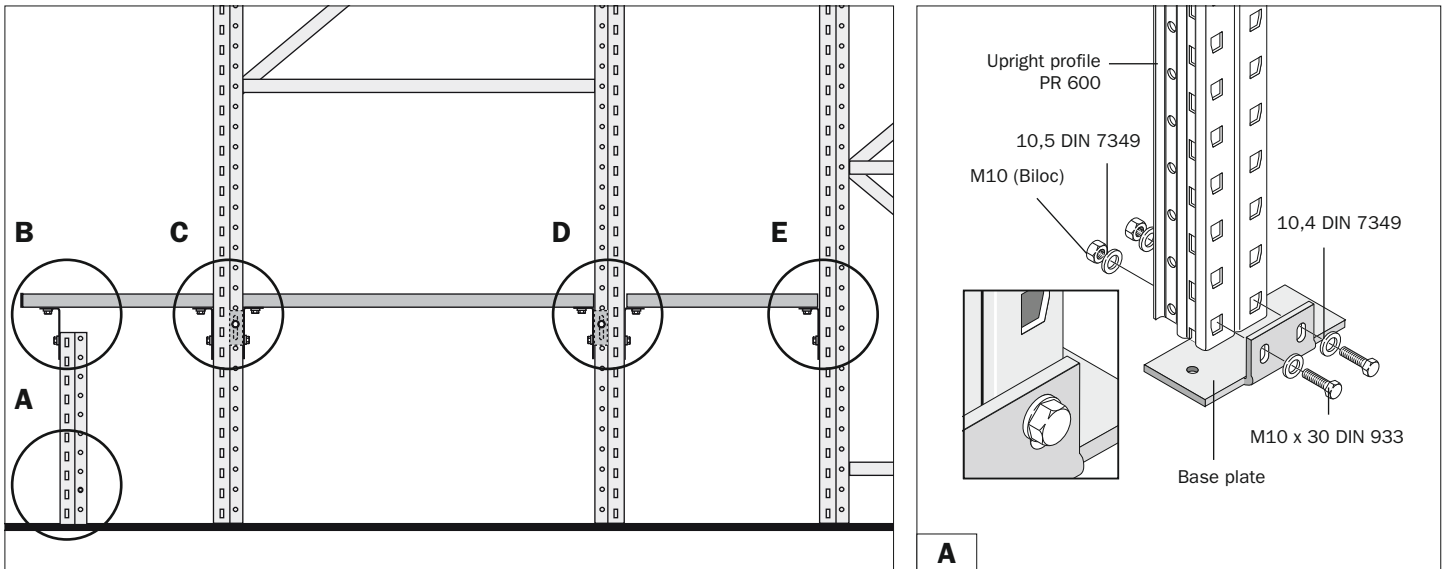

Support brackets

Supports P 60, P 65

Supports P 73, P 75, P 93,
P 95, P 13, P 15

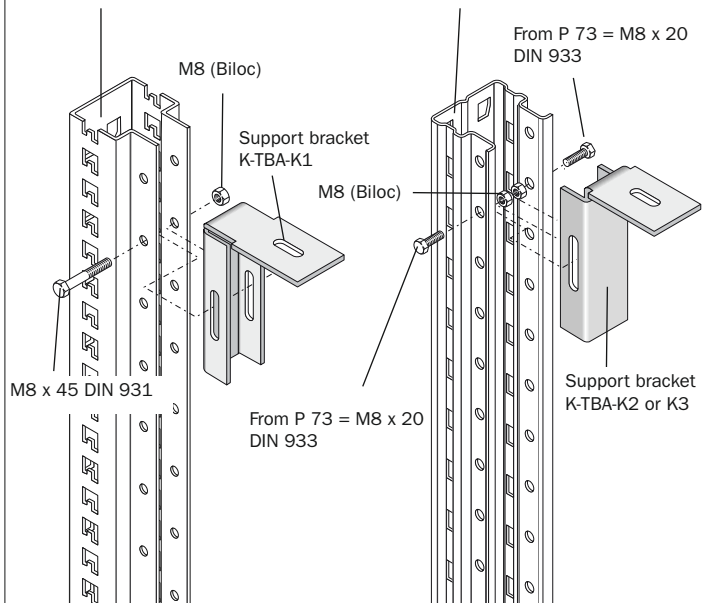

Assembly examples

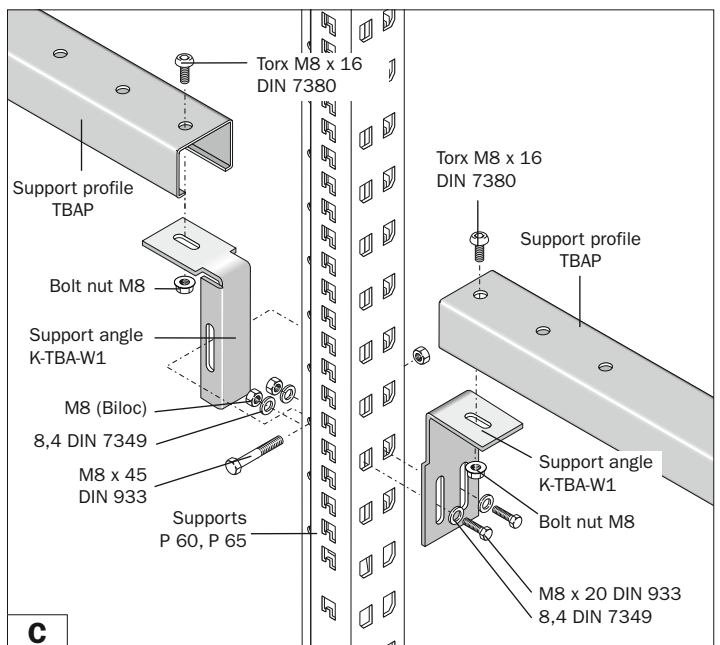
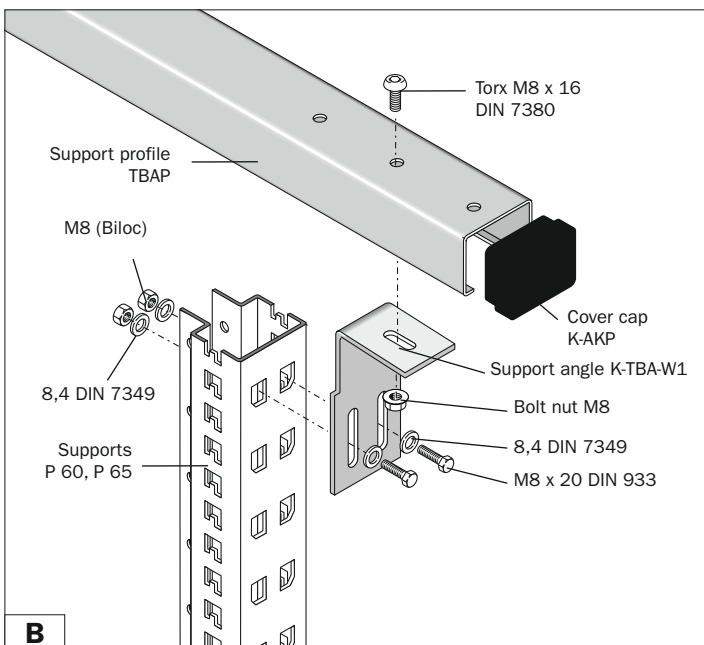
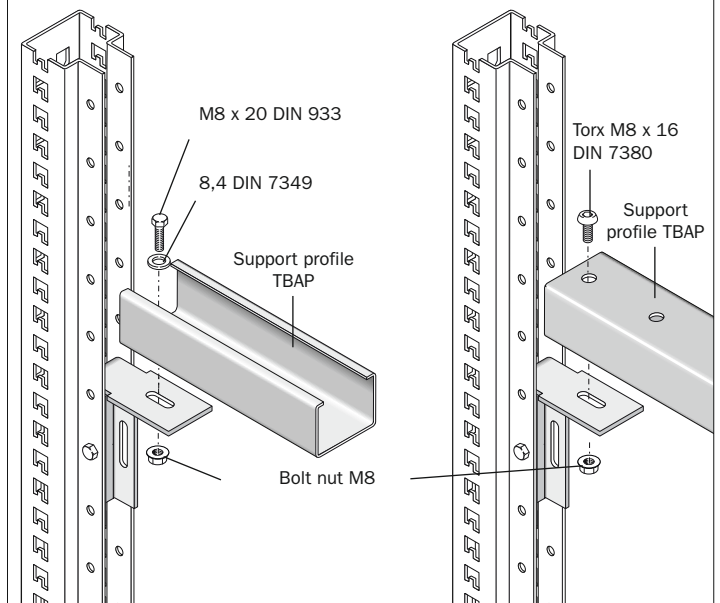

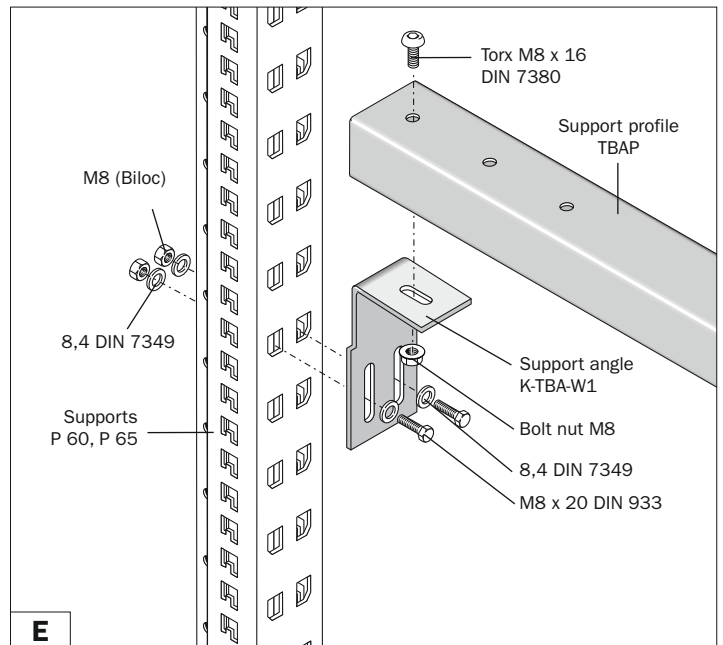
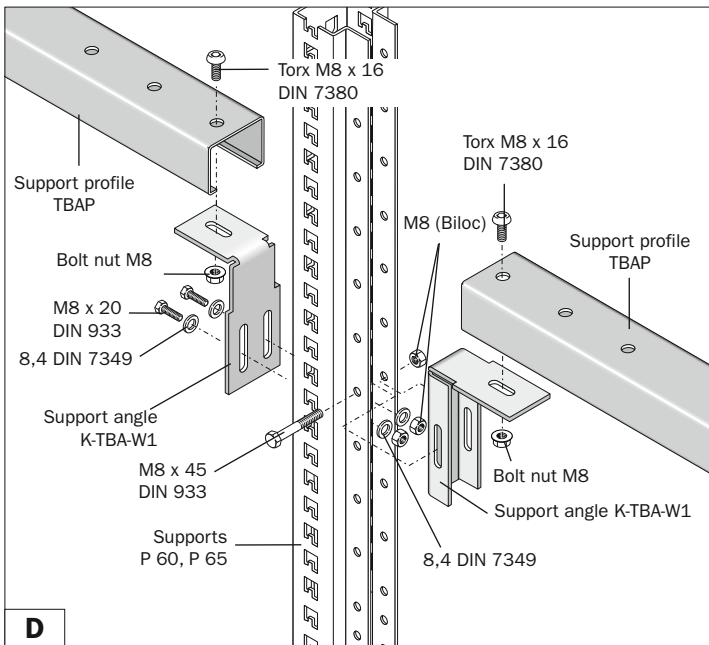

8.6 Assembly of installation tables

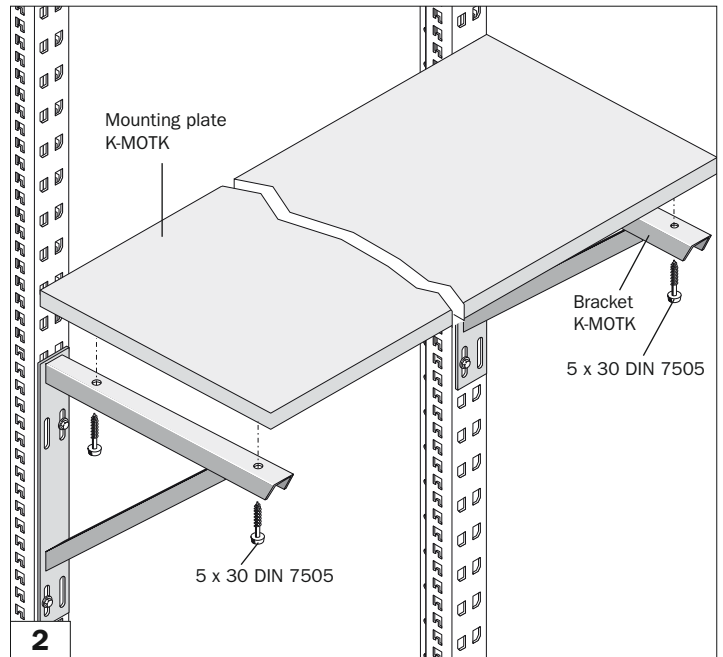
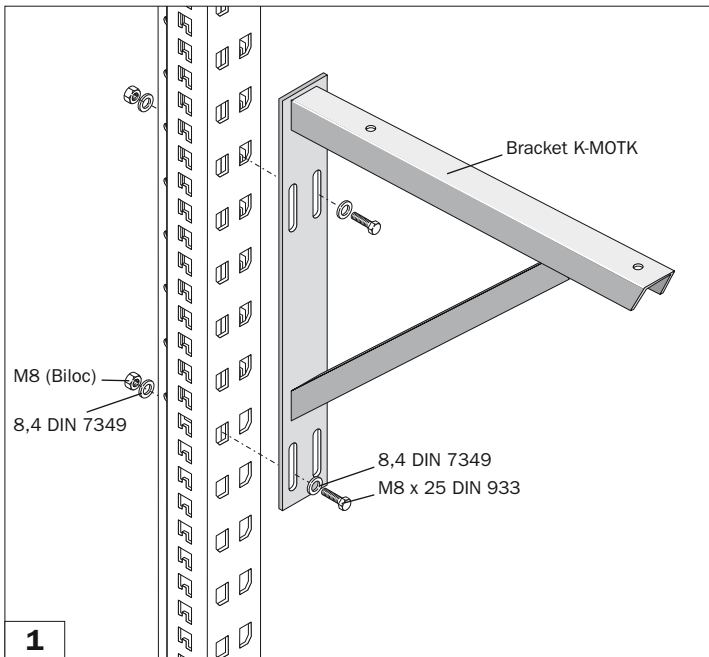

8.7 Assembly of upright adapter for third-party uprights, PR 300, PR 350, PR 400, PR 500 and LS 600

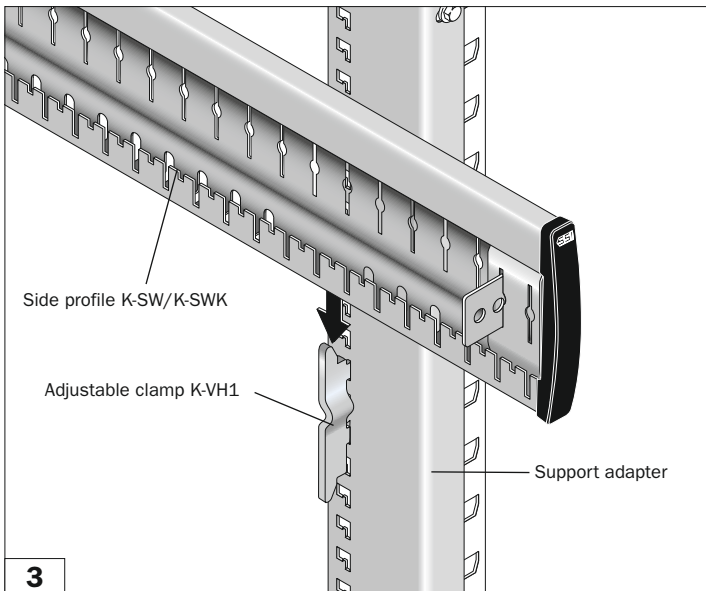
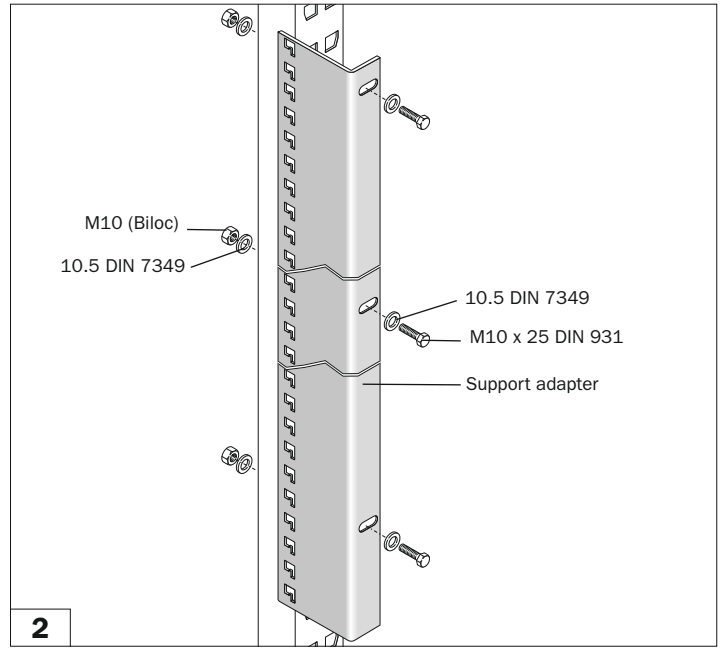
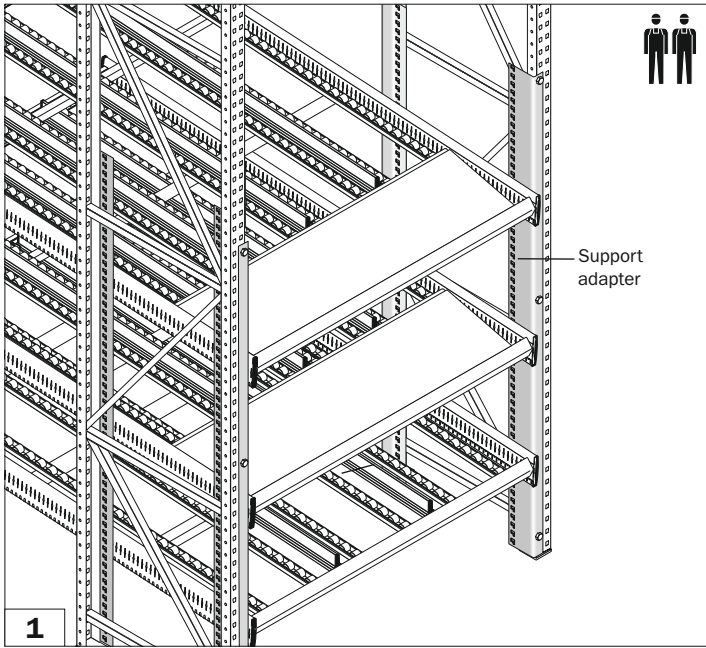

8.8 Assembly of angle protectors

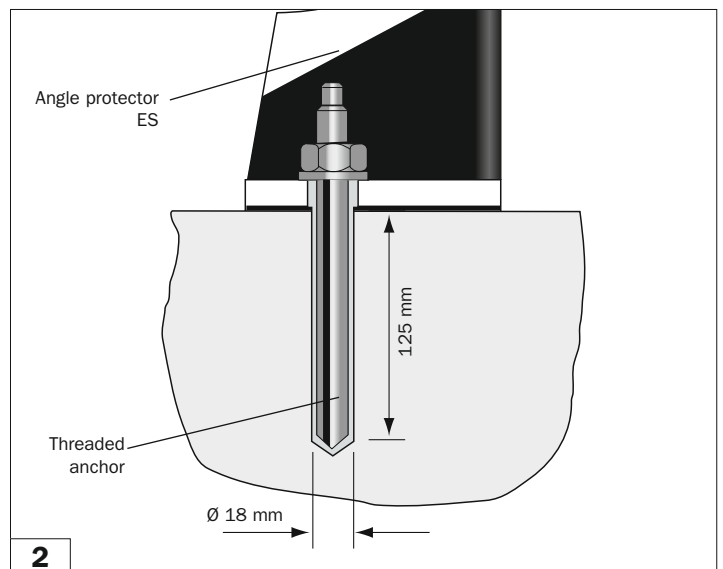
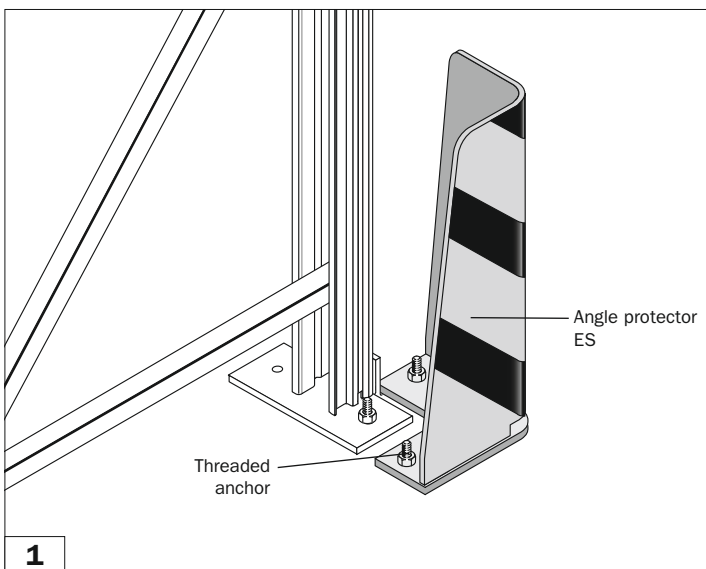

8.9 Assembly of mesh rear panels

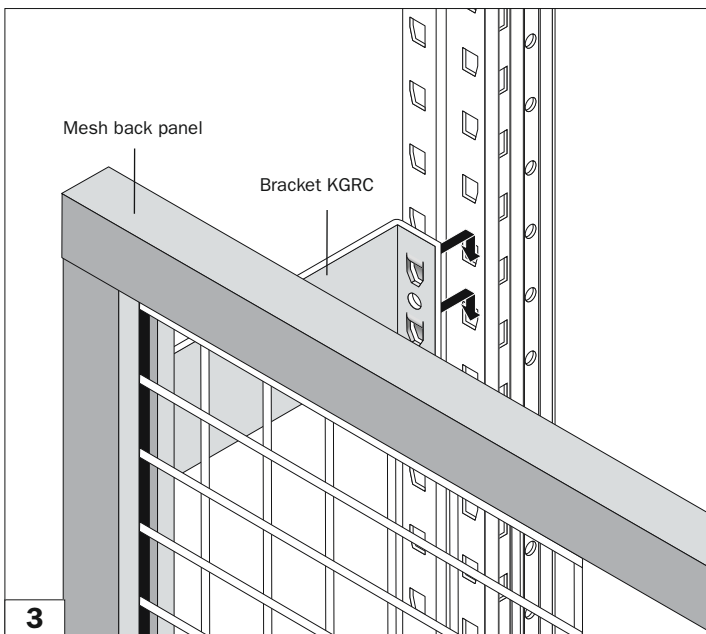
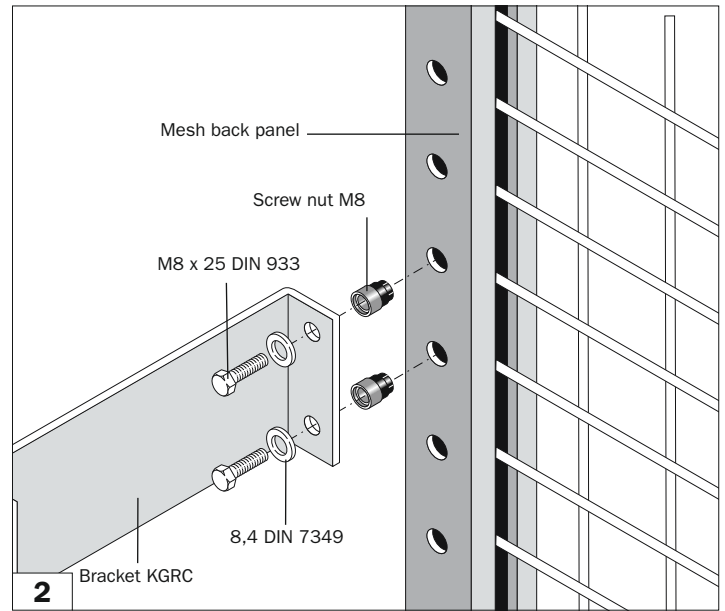
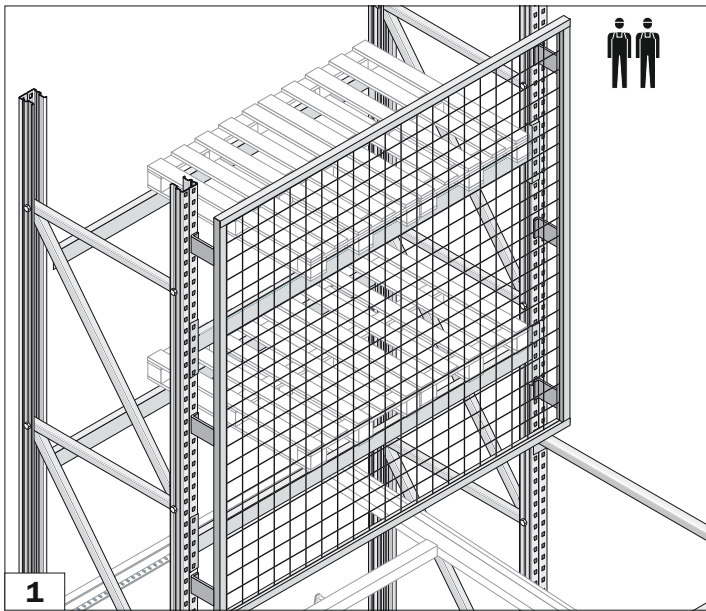

8.10 Assembly of end stops

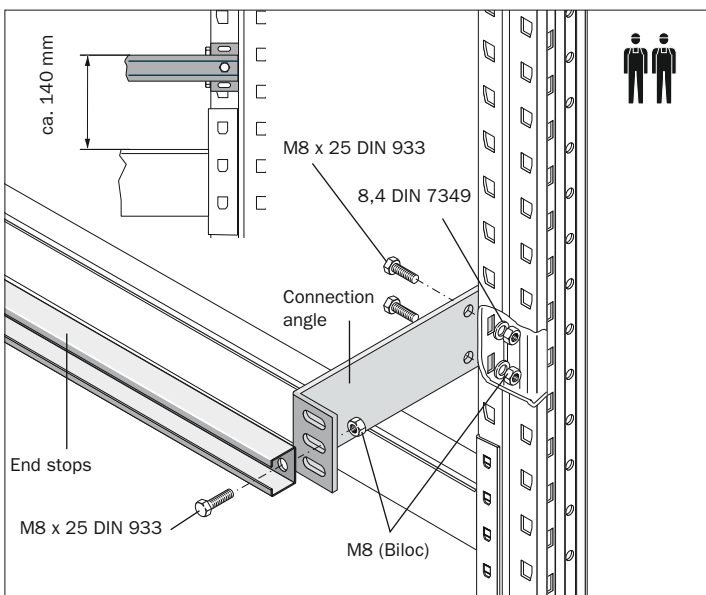

8.11 Bay load plate

