

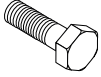

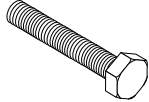







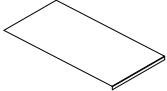
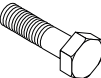

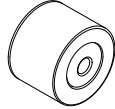



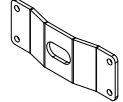
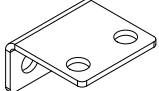

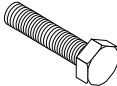
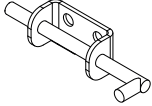
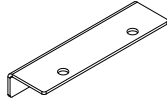
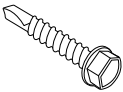
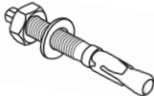
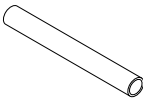
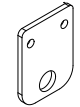

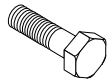
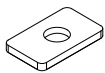
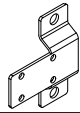
# montage handleiding

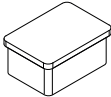
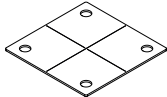
## Schuifhek

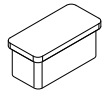
# Schuifhek bevestigingsmaterialen:

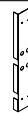
	<b>8x</b> Zeskantbout M10x50 / DIN933		<b>4x</b> Zeskanttapbout M16x200 / DIN931		<b>10x</b> Wiel Ø 50x20 mm		<b>2x</b> Palletopzetplaat 750x1460x2 mm
	<b>30x</b> Zeskantbout M10x70 / DIN933		<b>4x</b> Borgmoer M16 / DIN985		<b>4x</b> Geleidingswiel Ø 80x60 mm		<b>1x</b> Montagekit koker
	<b>40x</b> Borgmoer M10 / DIN985		<b>4x</b> Vlakke sluitring M16 / DIN125A		<b>2x</b> Vergrendelings- beugel (slotplaat)		<b>8x</b> Bevestigingsbeugel zijwiel enkel L/R
	<b>80x</b> Vlakke sluitring M10 / DIN125A		<b>2x</b> Zeskanttapbout M10x120 / DIN931		<b>1x</b> Grendel met veer		<b>4x</b> Bevestigingsbeugel zijwiel dubbel
	<b>12x</b> Zelfborende schroef zeskantkop 4,2x19		<b>8x</b> Keilanker M8x75 ETAG001-St-Zn		<b>4x</b> Buis RVS Ø 19x169 mm		<b>2x</b> Stelstrip wiel
	<b>4x</b> Zeskantbout M6x16 / DIN933		<b>8x</b> Zeskantbout M8x60 / DIN933		<b>8x</b> Schuifmoer M8 46x20x4mm		<b>1x</b> Bevestigingsplaat grendel
	<b>4x</b> Borgmoer M6 / DIN985		<b>8x</b> Zeskantmoer M8 / DIN934		<b>2x</b> insteekdop rechthoekig zwart 70x50mm		<b>2x</b> Contraplaat / voetplaat leuningpaal
	<b>4x</b> Vlakke sluitring M6 / DIN125A		<b>8x</b> Vlakke sluitring M8 / DIN125A		<b>4x</b> insteekdop rechthoekig zwart 50x25x1-2mm		
	<b>8x</b> Inbus bolkop bout M8x25 / DIN7380		<b>8x</b> Opvulbus RVS Ø 22x8 mm		<b>2x</b> Afdekkap verzinkt		

## Voorbeeld

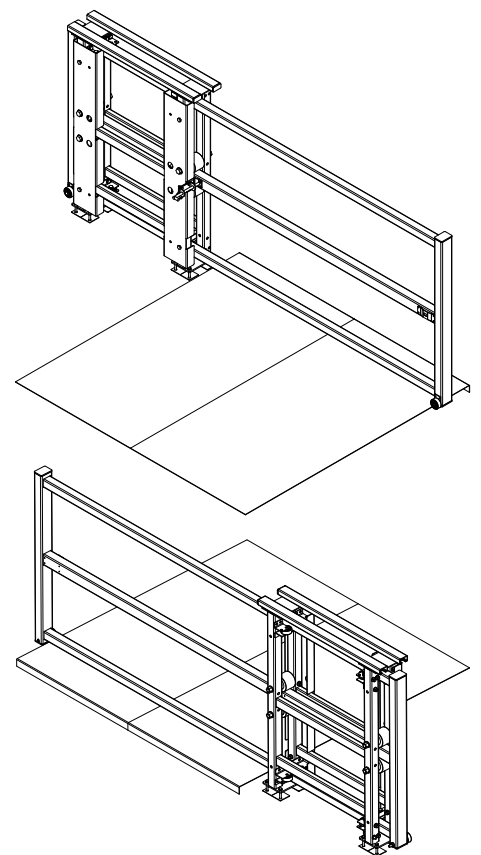

# Stap 1: Voormontage schuiframe:

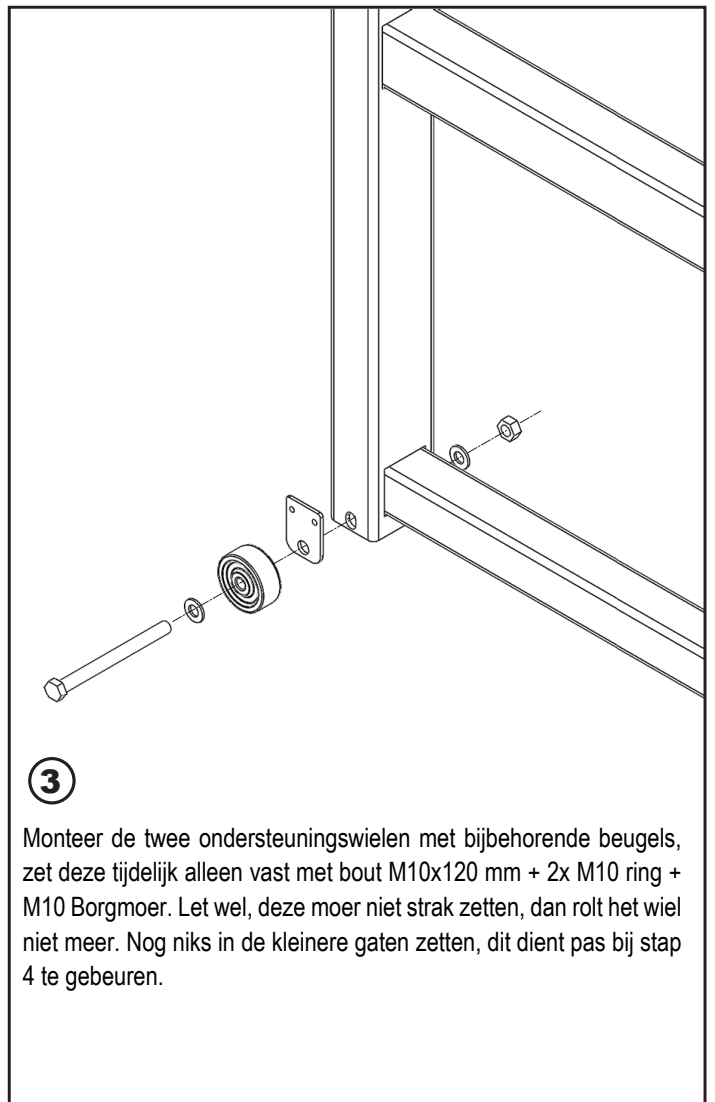
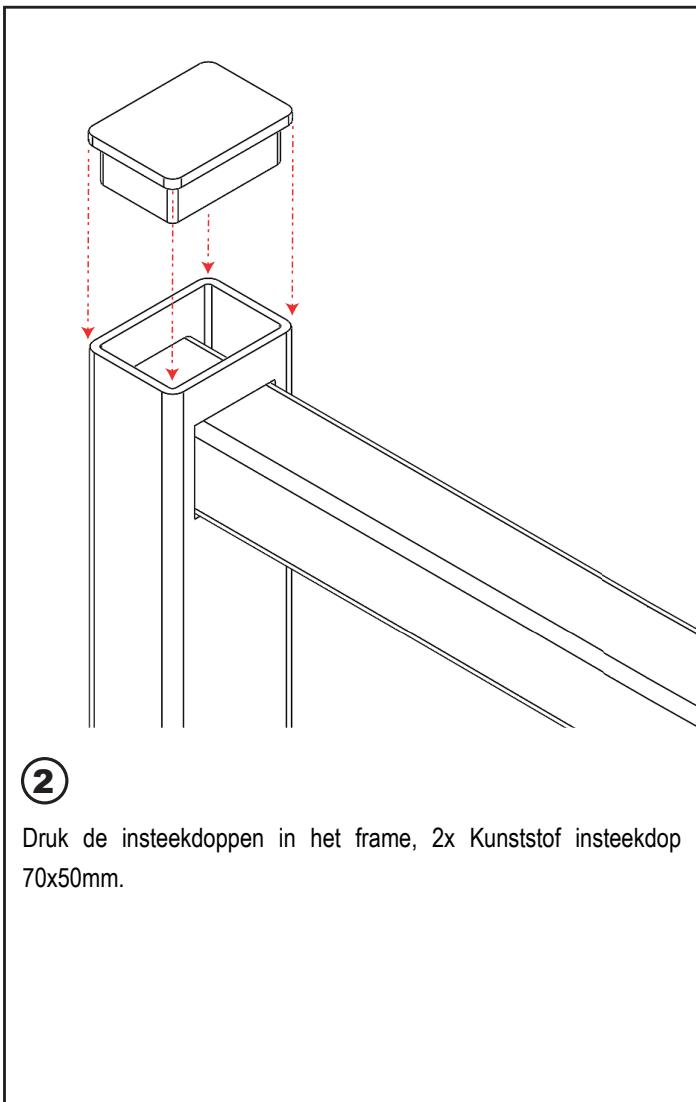
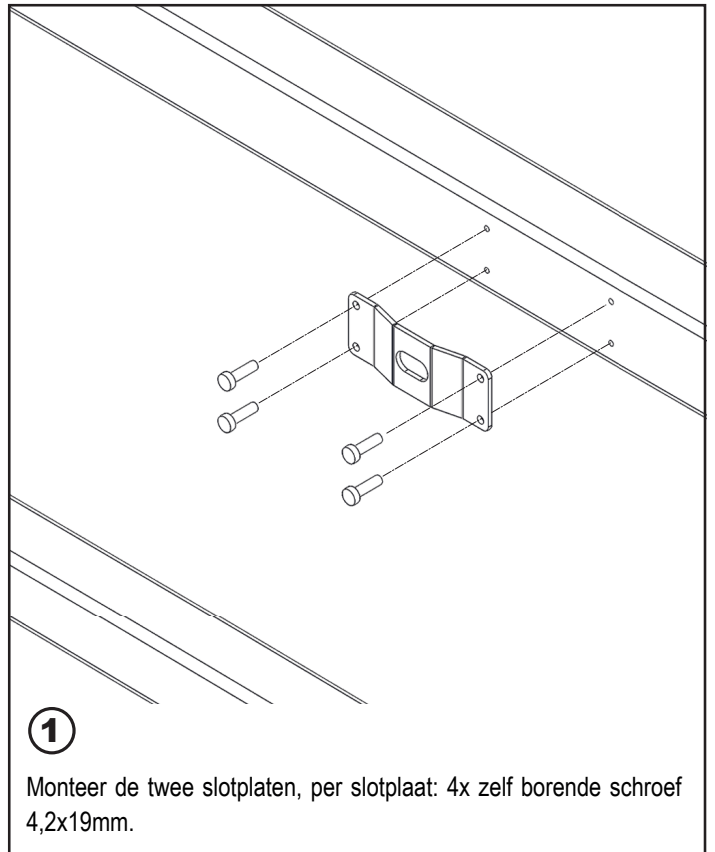
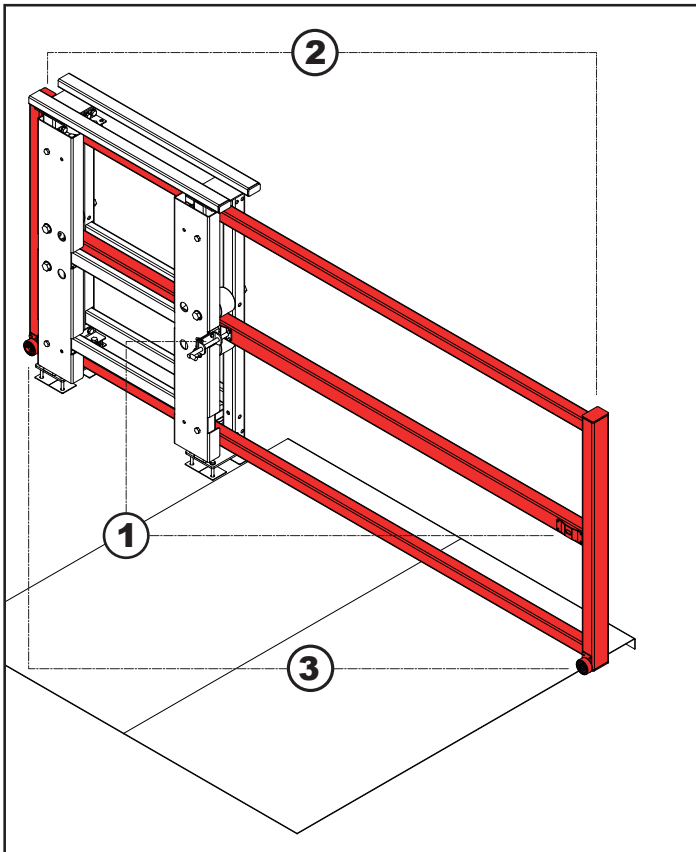

# Stap 2: Voormontage standframe:

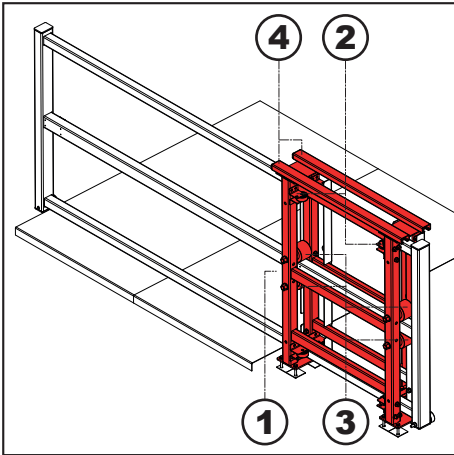

In deze stap wordt het volledige standframe gemonteerd.

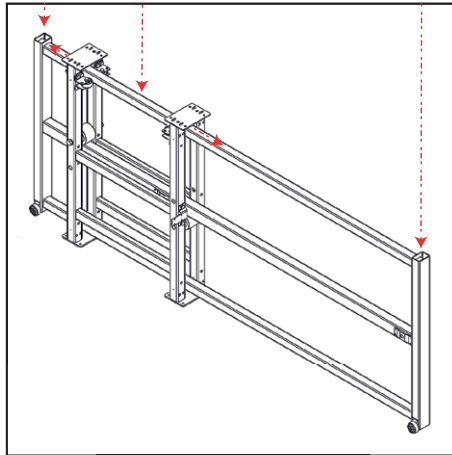

Plaats het schuifframe (stap 1) los tussen het standframe zodat het schuifframe aan beide zijden van het standframe er buiten steekt.

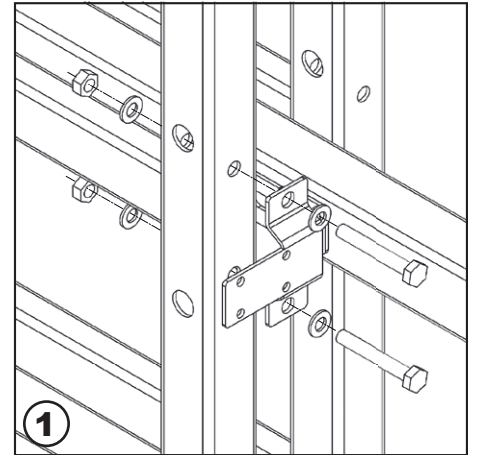

Monteer de slotbeugel op het standframe: 2x bout M10x70 + 4x M10 ring + 2x borgmoer M10.

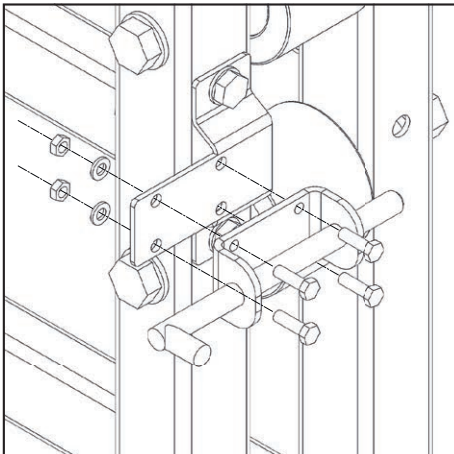

Monteer het veerslot op de slotbeugel: 4x bout M6x20 + 4x M6 ring + 4x M6 Borgmoer.

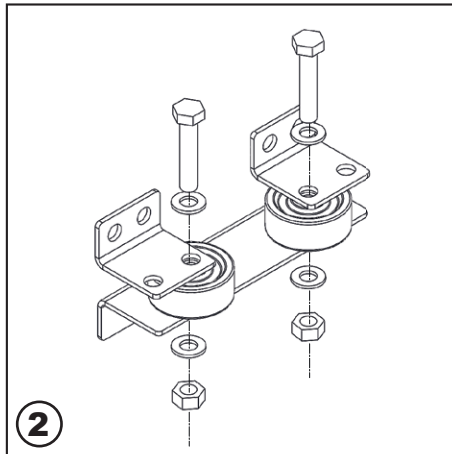

Plaats de beugels met zijwielen enkel bovenaan het standframe. Totaal twee sets\* met ieder 2 wielen (Ø 50 mm). Bij Stap 3 worden de zijwielen onderaan geplaatst.

\* Setsamenstelling: zie bovenstaande afbeelding.

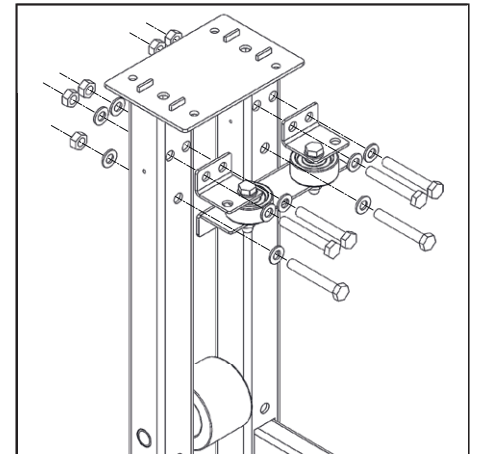

Per set: 6x bout M10x70 mm + 12x M10 ring + 6x M10 borgmoer, 2x bout M10x50 + 2x M10 borgmoer.

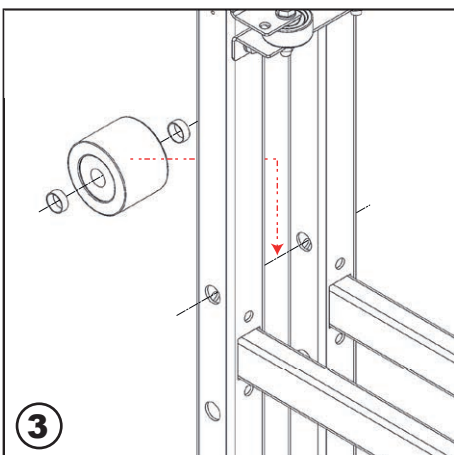

Monteer de 4 grote geleidingswielen (Ø 80mm) op het standframe. Zie ook volgende afbeelding

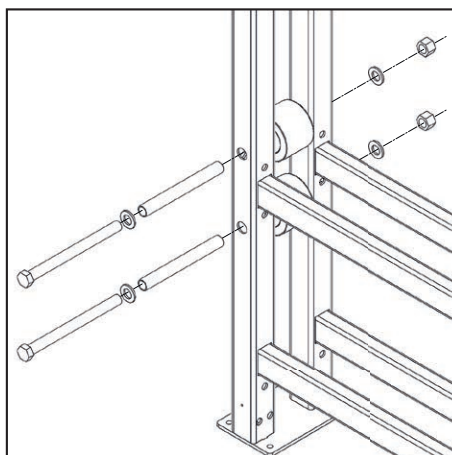

## Montagevolgorde per wiel:

- 1) Schuif de buis (169x19mm) door het wiel (Ø80x60mm) en de 2 opvulbussen (8x22mm)
- 2) Zet het geheel vast met 1x bout M16x200 + 2x ring M16 + 1x borgmoer M16.

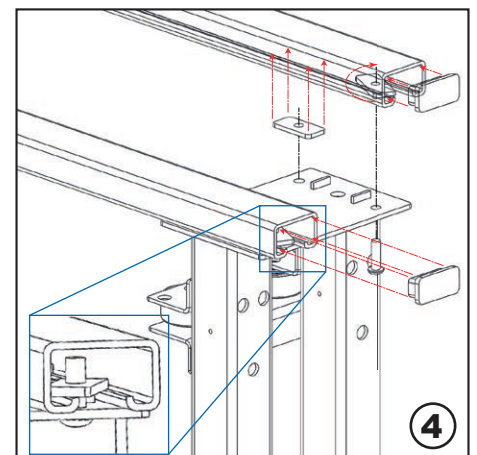

Monteer beide handleuningen op het standframe, per leuning: 4x bout M8x25 + 4x M8 schuifmoer. En plaats 4x kunststof insteekdoppen 50x25 mm in de uiteinden van de handleuningen.

# Stap 3: Montage op het vloerdek:

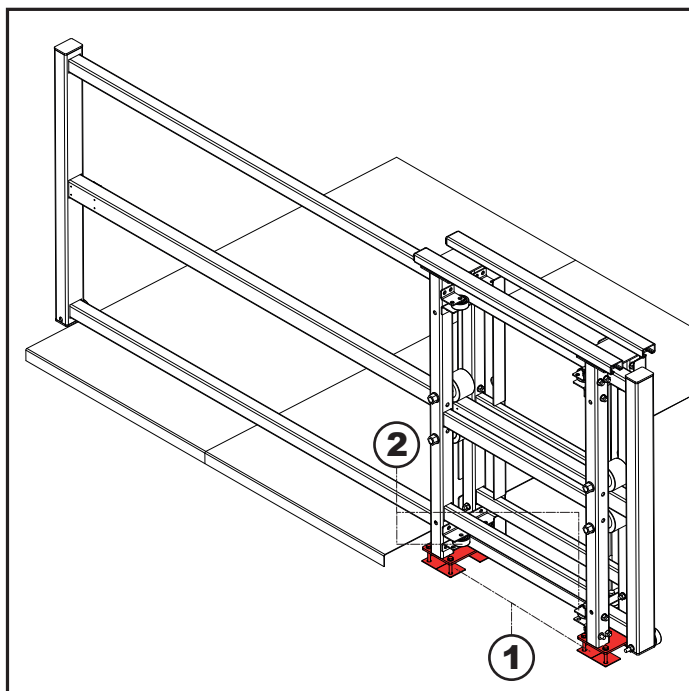

In deze stap wordt het schuifhek op de vloer bevestigd.

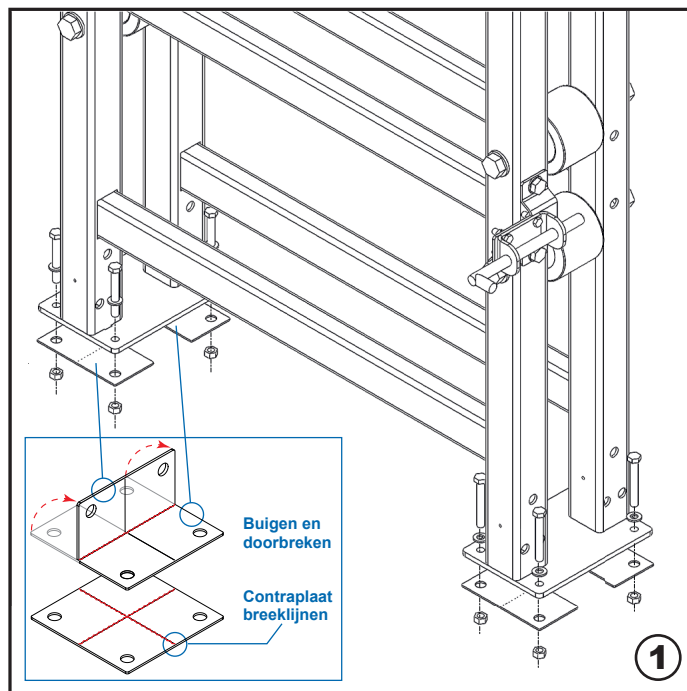

Teken de posities af en boor gaten door de vloer. Bevestig het standframe aan de vloerplaat middels 8x Bout M8x60 + 8x Ring M8 + 2x Contraplaat leuningwerk 120x120 mm + 8x Moer M8. Let op: De moeren worden aan de onderkant van de vloer aangedraaid en de contraplatten moeten op de breeklijn één keer gebroken worden vooraf montage. Mocht het hek op een betonnen ondergrond worden geplaatst, gebruik dan de bijgeleverde ankers M8x75 mm.

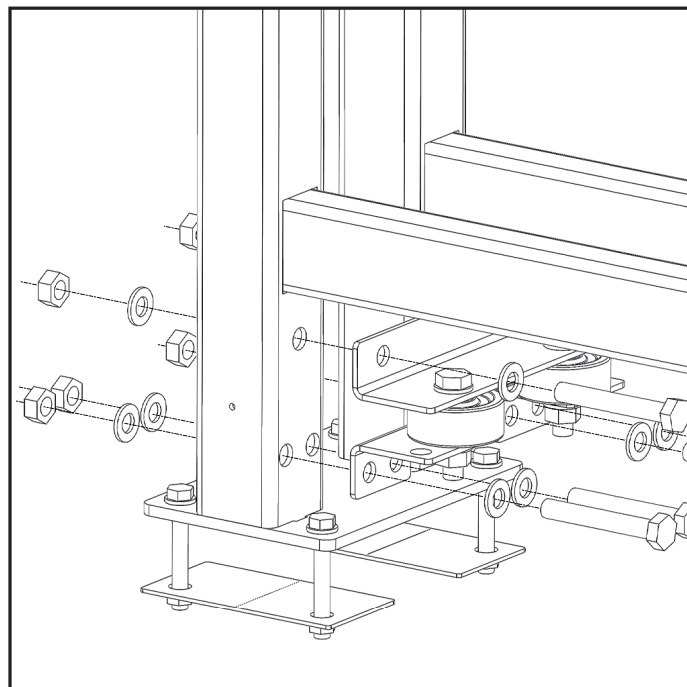
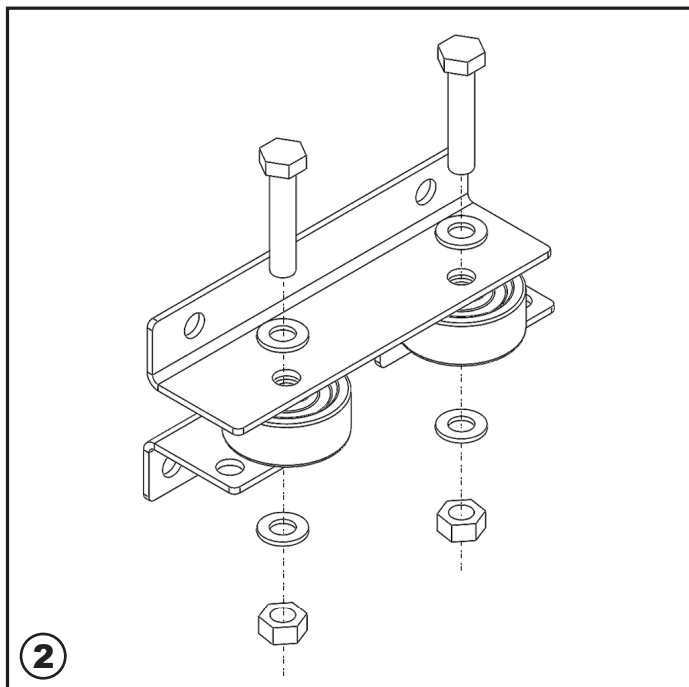

Plaats de beugels met zijwielen onderaan het standframe. Totaal twee sets met ieder twee wielen (diameter 50 mm). Per set: 6x Bout M10x70mm + 12x Ring M10 + 6x Borgmoer M10, 2x Bout M10x50 + 2x Borgmoer M10.

## Stap 4: Afstellen van het schuifframe:

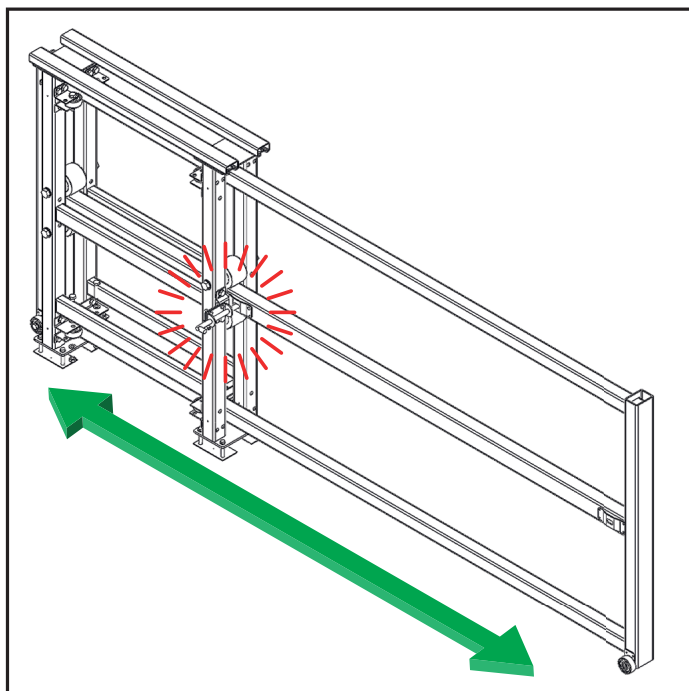

Controleer of het schuifframe goed rolt en goed in het veerslot valt, corrigeer eventuele hoogteverschillen door de ondersteuningswielen (stap 1.3.) op hoogte te verstellen en lichtjes vast te zetten met de bout M10x120 mm + moer.

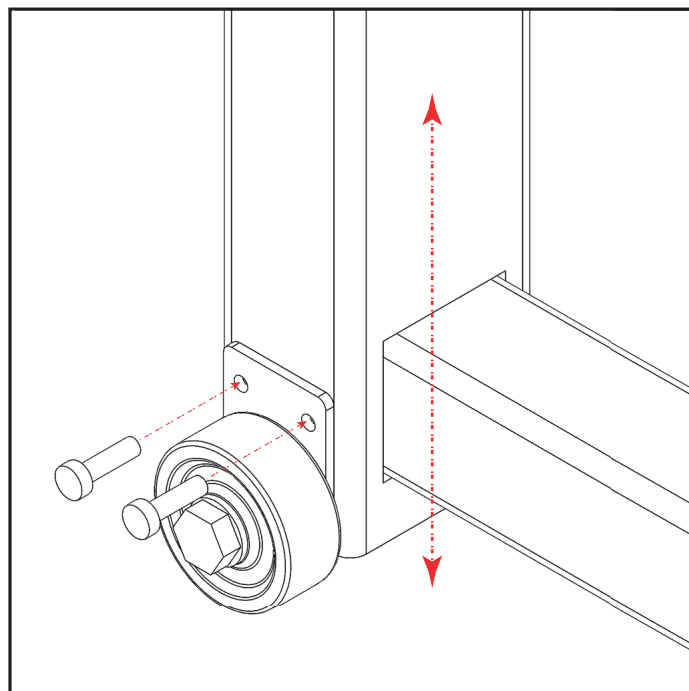

Na het afstellen van de hoogte van de wielen dient deze hoogte te worden geborgd door iedere beugel vast zetten met: 2x Zelfborende schroef, 4,2x19mm.

## Stap 5: Montage afdekkappen

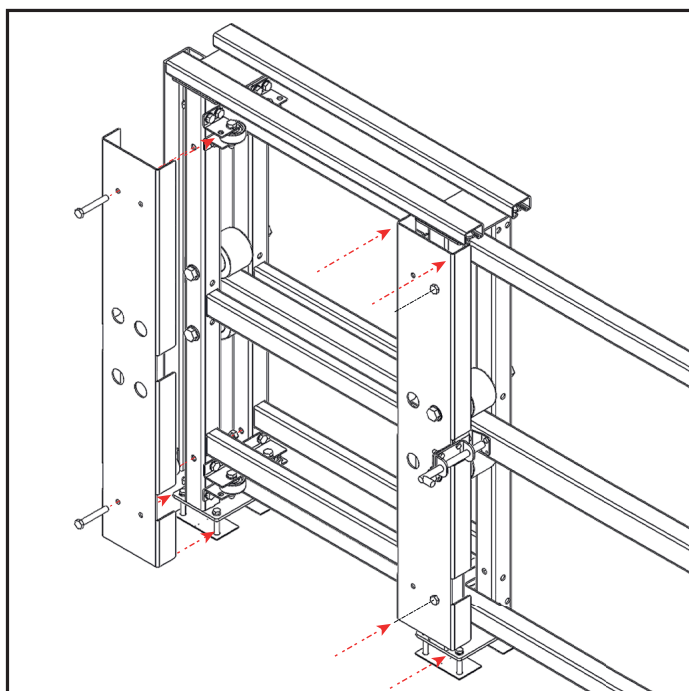

Monteer de twee afdekkappen per afdekkap met: 2x M10x70mm + 2x M10 Vlakke sluiting + 2x M10 Borgmoer

## Stap 6: Montage palletopzetplaten

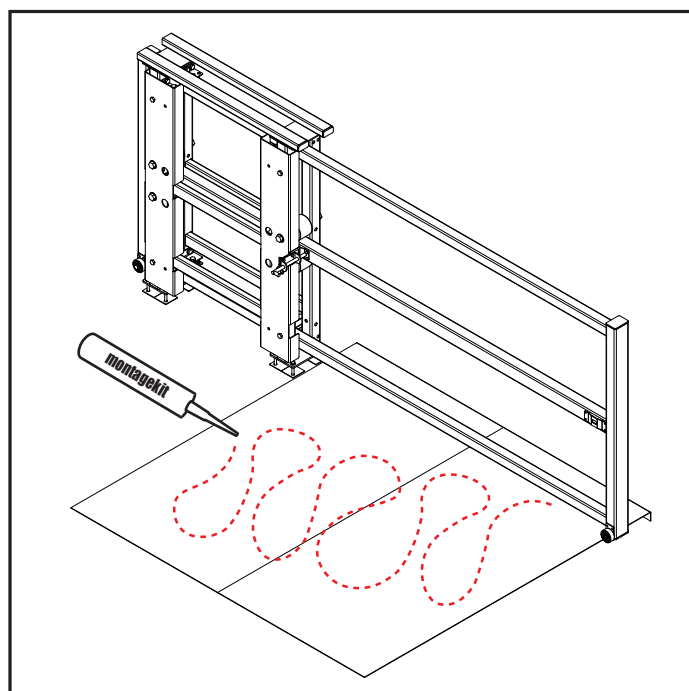

Monteer de palletopzetplaten op het vloerdek met de montagekit.

# Notities:

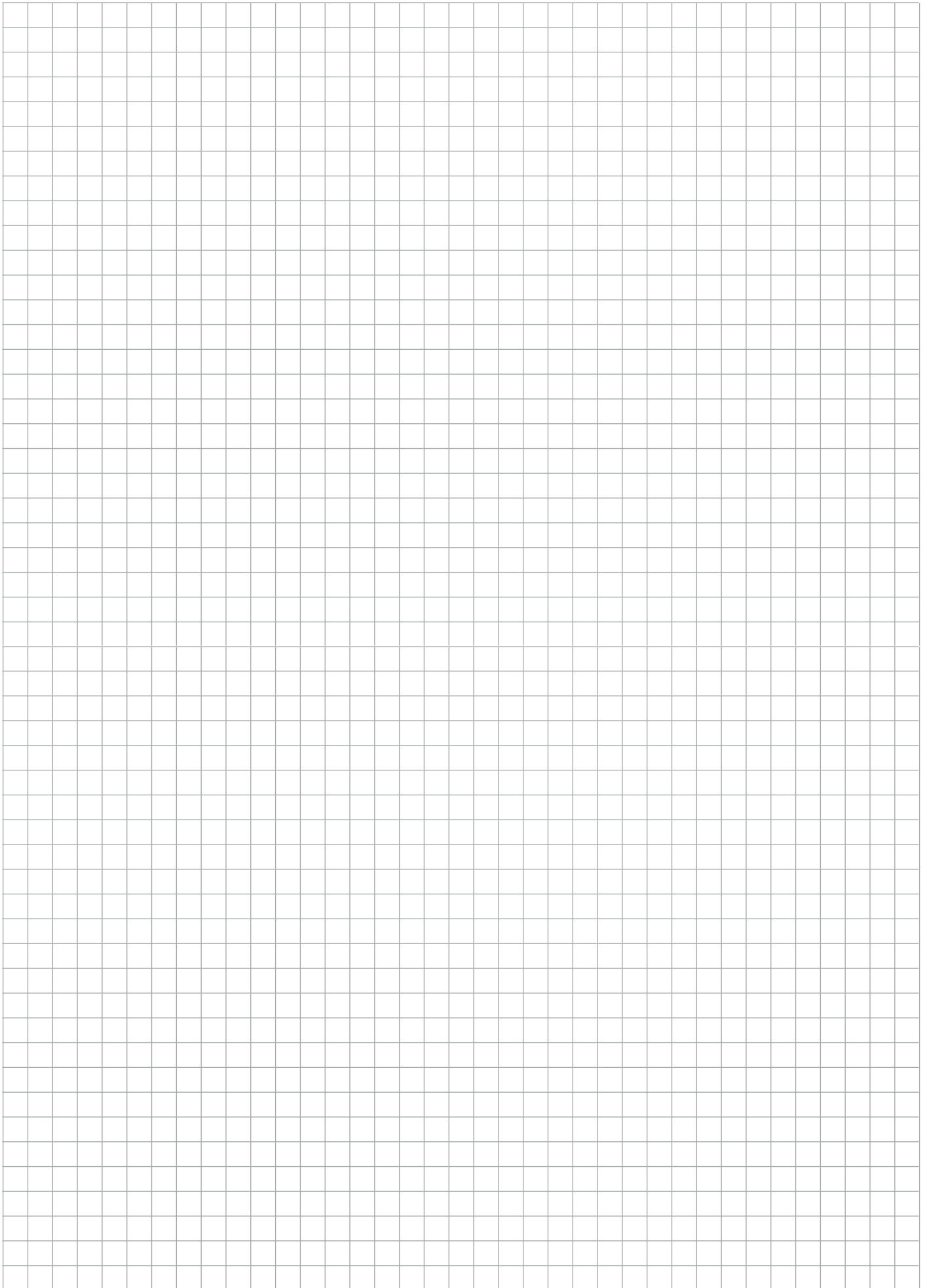



Ijsselstraat 9-13 \ 5347 KG Oss \ The Netherlands \ T +31 (0)412 667650 \ E [info@begra.nl](mailto:info@begra.nl) \ [www.begra.nl](http://www.begra.nl)  
[Iban](#) NL80 RABO 0146 3423 21 \ [KvK](#) Oost Brabant 17207142 \ [BTW](#) 8180.3852.4B01